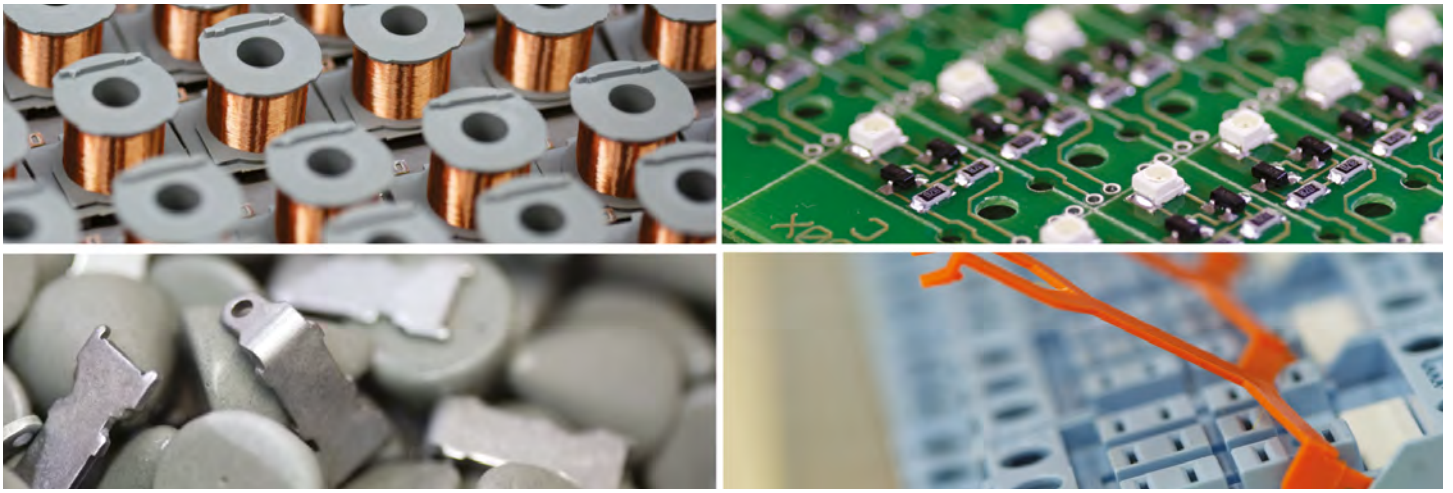




WORLD OF RELAYS

SOLID STATE RELAYS CATALOGUE

WoR 2.1 | English



ComatReleco at a glance

ComatReleco is one of the world's leading suppliers of high-quality relays and contactors of all kinds. With one of the broadest product portfolios, including customized solutions, ComatReleco serves customers in the industrial automation and building installation, rail and transportation segments. Our core competencies are industrial relays, timing relays, monitoring relays and contactors. These are installed with the latest semiconductor technologies or also with the traditional electromechanical design.

Designed in Switzerland, assembled in...

ComatReleco continuously invests in research and development, thus ensuring a consistently high rate of innovation. Several international patent applications support this fact. Our research and development team is headquartered in Switzerland and has access to additional qualified employees in our subsidiaries in Germany and China. With a share of more than 20% of total research and development costs, we outperform many global players in our segment.

Customer orientation and quality management

ComatReleco has a group-wide quality management system with real-time access to test and inspection protocols. Our relays and contactors are 100% tested at the end of the production line. On arrival of the goods at our central warehouse in Switzerland, another quality test is carried out.

Are you using a ComatReleco product or are you looking for a suitable solution? Our support centre in Switzerland will be happy to help you find the right relay or contactor for your application. ComatReleco is known for the world's largest number of customized solutions for industrial, time and monitoring relays and contactors.

Headquarters in Switzerland – international presence

The warehouse and logistics are managed centrally at the headquarters in Switzerland. Production is diversified and optimized in terms of quality, costs and logistics criteria. Our production sites are located in Europe and Asia. Through our network of distribution partners, the Group is present on all world markets. ComatReleco has been part of the management team since 2003.

WORLD OF RELAYS

Find your suitable documentation

ComatReleco offers a variety of customized solutions. We therefore have different documentation for different areas of application.



GENERAL-, TRANSPORTATION & RAILWAY-, SOLID STATE RELAY-CATALOGUE, PLC & HMI CATALOGUE

Please visit comatreleco.com or contact our support at support@comatreleco.com for more information.

Index

1	Relays & Contactors	Page 7
1.1	General Informations	8
2	Solid State Relays socket mounted	Page 11
2.1	Solid State Relays	12
3	Solid State Relays panel or DIN rail mounted	Page 25
3.1	Overview	27
3.2	SP1M	29
3.3	SP1P	39
3.4	Accessories	79
4	Solid State Contactor	Page 85
4.1	Solid State Contactor	86
5	Softstarter	Page 101
5.1	Softstarter	103
5.2	DC Motor Controller	119
6	Worldwide Sales Network	Page 125

1

2

3

4

5

6

1 Relays & Contactors

Chapter	Page
General Informations	8

2 Solid State Relays socket mounted

Type	Page
CRINT-C135R	21
CRINT-C138R	23
CRINT-C1x5	20
CRINT-C1x8	22
CSS-I	12
CSS-N	16
CSS-P	18
CSS-Z	14
R10-Z1I	13
R10-Z1N	17
R10-Z1P	19
R10-Z1Z	15

3 SSR panel or DIN raiinted mounted

Type	Page
HS_003	80
HS_004	80
HS_005	80
HS_006	80
HS_007	81
HS_008	81
HS_010	81
HS_012	81
HS_015	82
HS_020	82
HS_022	82
HS_025	82
SP1MXF-TI0380	35
SP1MXF-TIX240	31
SP1MXF-TZX0240	30
SP1MXF-TZX0380	34
SP1MXN-TI0240	33
SP1MXN-TIX380	38
SP1MXN-TZX0240	32
SP1MXN-TZX0380	36
SP1M/pad	83
SP1MXN/cover	83
SP1PXF-ATX0240	40
SP1PXF-TZX0240	41
SP1PXF-TZX0240	42
SP1PXN-TIX0240	44
SP1PXN-TIX0240	46
SP1PXN-TIX0240	48
SP1PXN-TIX0480	50
SP1PXN-TIX0480	52
SP1PXN-TIX0480	54
SP1PXN-TIX0600	56
SP1PXN-TIX0600	58
SP1PXN-TIX0600	60
SP1PXN-TZX0240	43
SP1PXN-TZX0240	45
SP1PXN-TZX0240	47
SP1PXN-TZX0480	49
SP1PXN-TZX0480	51
SP1PXN-TZX0480	53
SP1PXN-TZX0600	55
SP1PXN-TZX0600	57
SP1PXN-TZX0600	59
SP1PXS-TIX0240	62
SP1PXS-TIX0240	64
SP1PXS-TIX0240	66
SP1PXS-TIX0480	68
SP1PXS-TIX0480	70
SP1PXS-TIX0480	72
SP1PXS-TIX0600	74
SP1PXS-TIX0600	76
SP1PXS-TIX0600	78
SP1PXS-TZX0240	61
SP1PXS-TZX0240	63
SP1PXS-TZX0240	65
SP1PXS-TZX0480	67
SP1PXS-TZX0480	69
SP1PXS-TZX0480	71
SP1PXS-TZX0600	73
SP1PXS-TZX0600	75
SP1PXS-TZX0600	77
SP1/grease	83
SP1P/pad	83
SP1PXN/cover	84

4 Solid State Contactor

Type	Page
CC1H215	86
CC1H230	87
CC1H250	88
CC1H415	89
CC1H430	90
CC1H450	91
CC1H463	92
CC3H410	93
CC3H420	94
CCR3H410	95
CPC1230	96
CPC1250	97
CPC1430	98
CPC1450	99

5 Softstarter

Type	Page
CCL33H415US	106
CCL33H425US	107
CCL33H435US	108
CCM33H450US	113
CCM33H530USi	114
CCM33H550USi	115
CCM3H403USi	109
CCM3H415	110
CCM3H415DS	111
CCM3H425	112
CCMB3H425	116
CMC1	120
CMC14	121
CMC15	122
CMC16	123
CTC3415	104
CTC3425	105
KDM3-24	124

6 Worldwide Sales Network

Country	Page
ARGENTINA	128
AUSTRALIA	126
AUSTRIA	127
BELGIUM	127
BOLIVIA	128
BOSNIA AND HERZIGOVINA	127
BRAZIL	128
BULGARIA	128
CANADA	128
CHILE	128
CHINA	126
COLOMBIA	128
CROATIA	127
CZECH REPUBLIC	127
DENMARK	127
ECUADOR	128
ESTONIA	127
FRANCE	127
FINLAND	127
GERMANY	127
GREAT BRITAIN	127
GREECE	127
HUNGARY	127
INDIA	126
IRAN	128
IRELAND	127
ITALY	127
LATVIA	127
LITHUANIA	127
MALAYSIA	126
MEXICO	128
NETHERLANDS	127
NEW ZEALAND	126
NIGERIA	127
NORWAY	127
PAKISTAN	128
POLAND	127
REPUBLIC OF MACEDONIA	127
RUSSIA	127
SERBIA	127
SINGAPORE	126
SLOVAKIA	127
SLOVENIA	127
SOUTH KOREA	126
SPAIN	127
SWEDEN	127
SWITZERLAND	127
TAIWAN	126
THAILAND	126
TURKEY	127
UAE	128
UKRAINE	127
UNITED STATES	128
URUGUAY	128
VIETNAM	126

1 Relays & Contactors

Chapter	Page
1.1 General Information	8

Contacts

There are different contact types. The main distinction is between single contacts and twin contacts. While single contacts are more suitable for higher loads, twin contacts are significantly more reliable at small loads, i.e. <math>< 24V, < 100mA</math>.

Contact Material

There is no all-purpose contact!

AgNi is used as standard material for a wide range of applications. AgNi contacts with hard gold plating (up to 5µm) are offered for applications in aggressive atmosphere.

Relays with gold contacts are approved for relatively high currents (e.g. 6A, 250V), but in practice values of 200mA, 30V should not be exceeded for operation with intact gold plating.

Relays with a tungsten pre-contact are available for very high switch-on currents (up to 500A, 2.5ms). For some applications AgNi contacts with gold flashing (0.2µm) are available. The purpose is corrosion protection during storage. Tin oxide is specially appropriated for load with high-inrush current.

Minimum load

The minimum load value is a recommended value under normal conditions such as regular switching, no special ambient conditions, etc. Under these conditions reliable switching behaviour can be expected.

Contact resistance

Initial values of resistance of contact can vary with the use, load and others conditions.

Typical values when the relay is new is about 50mΩ.

Contact spacing

Normally all contacts have an air gap between 0.5 ... 1.5mm when they are open. They are referred to as µ contacts. According to the Low-Voltage Directive and the associated standards these contacts are not suitable for safe disconnection.

For switching of DC loads large contact clearances are beneficial for quenching the arc. See relays with "Cx-Gyz" naming. "G" stands for extended contact gap of 3mm.

Switching capacity

The contact switching capacity is the product of switching voltage and switching current.

For AC the permitted switching capacity is generally high enough to handle the max. continuous AC-1 current over the whole voltage range. For DC the load limit curve must never be exceeded, because this would lead to a remaining switch-off arc and immediate destruction of the relay. The order of magnitude of the DC switching capacity is a few 100W (DC-1).

Drive (coil)

The drive of a relay refers to the coil plus connections. The coil has special characteristics, depending on the rated voltage and the type of current.

Coil design

The coil consists of a plastic former (resistant up to about 130°C) and doubly insulated high-purity copper wire, temperature class F. The winding must withstand threshold voltages (EN 61000-4-5) of more than 2000V. This is ensured through forced separation of the start and end of the winding.

Coil resistance and other properties

Each coil has an ohmic coil resistance that can be verified with an ohmmeter. The specified coil resistance applies to a temperature of 20°C. The tolerance is ±10%.

For AC operation the coil current will not match the ohmic value, because self-inductance plays a dominant role. At 230V this may reach more than 90H. When a relay is switched off, self-inductance results in a self-induced voltage that may affect the switching source (destruction of transistors, EMC problems).

Drive voltages

A distinction is made between the standardised voltages according to EN 60947 as guaranteed values, and typical values that can be expected with a high degree of probability.

Pick-up voltage, Release voltage

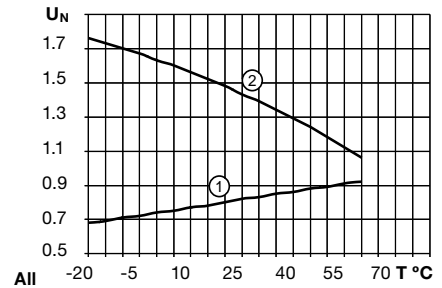
The pick-up voltage is the voltage at which the relay engages safely. For DC the typical trip voltage is approx. 65% of U_{nom} , for AC approx. 75%. The release voltage, on the other hand, is approx. 25% or 60% respectively.

For DC these voltages are strongly temperature-dependent, according to the temperature coefficient of Cu (See curve 1). This is not the case for AC, where the inductive resistance is the controlling factor, which is practically constant over a wide temperature range. With AC, in a certain undervoltage range the relay may hum, and the armature may flutter. This voltage range must be avoided.

Operating voltage range

Unless specified otherwise, the following characteristic curve applies for the operating voltage range (See curve 2). The upper limit of the coil voltage is determined by self-heating and the ambient temperature. Self-heating through contacts under high load must not be underestimated. It may be higher than the power dissipation in the drive.

During intermittent operation significantly higher over-voltages temporary may occur for short periods. If in doubt please consult our specialists.



All -20 -5 10 25 40 55 70 T °C

General design

ComatReleco Relays are made from high-quality, carefully selected materials. They comply with the latest environmental regulations such as RohS. Their meticulous design makes them particularly suitable for industrial applications and installation engineering. They are particularly service-friendly through robust terminals, mechanical position indicating device a standard, manual operation, dynamic, permanent characteristics.

Colour coding for manual operation as a function of the coil voltage is another useful feature. Further options such as different coil connections, free-wheeling diode, LED display, bridge rectifier for AC/DC drives etc., and short-term availability of special versions for practically any drive voltage up to DC 220V /AC 400V leave nothing to be desired.

Apart from a few special versions, in general, ComatReleco industrial relays feature manual operation (push/pull) and a mechanical position indicating device.

For safety reasons, manual operation may be replaced with a black button, if required.

Coil connections

Different coil connections can be integrated in the relay as an option.

For DC a cost-effective free-wheeling diode is available. Please note that the stated release times are generally specified without the coil connection. While an additional LED status indicator has practically no effect, a free-wheeling diode (D) will lead to an increase in release time by a factor 2 to 5, or 10ms to 30ms. For AC VDRs or RC elements may be used. In this case resonance effects may have to be considered. VDRs and common RC elements may increase release times by less than 5 ms.

Relays

General Information

Standards, conformities

All ComatReleco relays feature the CE mark to indicate that CE standards apply e.g. 2kV surge resistance according to EN 61000-4-5.

A significant and not generally available characteristic is that the coils and in particular the connections are able to withstand the voltage spikes that may occur in practice.

In addition, the relays feature various technical approvals depending on the respective relay code, and they comply with further standards and guidelines. The main technical approvals include cURus, CCC, Lloyd's Register, cULus and EAC. The associated information is provided in the data sheets.

Switching classes

EN 60947 defines different switching classes that specify the suitability of contacts for different load types.

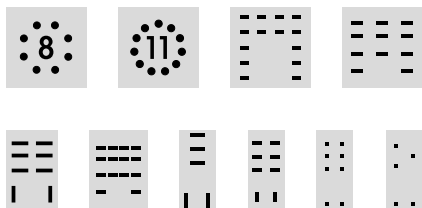
Example:

- AC-1 = Ohmic AC load
- AC-3 = Motor loads
- AC-15 = Power contactors, solenoid valves, solenoids
- DC-1 = Ohmic DC load
- DC-13 = DC contactors, solenoids

UL60947 contains different technical approval criteria such as general purpose, control application etc. Switching classes are defined based on the electrical switching capacity, e.g. B600 etc.

Choosing the right Socket

For plug-in industry, interface, time, and monitoring relays, we offer sockets with the corresponding pin configuration and various layouts for the terminal connectors. For easy identification, you'll find those symbol referring to the matching socket.



Main technical approvals and standards

Country	Technical approval
China	 Authority: CQC Specification GB14048.5-2001
Russia	 Authority: KORPORATSIA STANDART Specification TP TC 004/2011
Worldwide / USA / Canada	 Authority: UL Specification C 22.2; UL 60947
United Kingdom	 Authority: GB Lloyd's Register of Shipping
Europe / Worldwide	 Railway EN 50155

Utilisation categories according to EN 60947-4-1/-5-1

Pollution category

Cat. 1
Dry, non-conductive contamination without further effect

Cat. 2
Occasional conductive contamination, short duration due to moisture condensation

Cat. 3
Dry, non-conductive and conductive contamination with moisture condensation

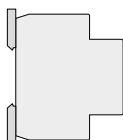
Cat. 4
Contamination with persistent conductivity through conductive dust, rain

Protection class IP according to EN 60529 and other standards. Industrial relays and their sockets can be classified as follows:

Socket IP20: Contact safety
Relay IP40/IP50: not watertight, but protected against ingress of coarse contaminants.

Electrical Distributor DIN 45mm

All devices with a housing fitting in an electrical distributor with a front of 45mm are marked with the following symbol.



Further information and tips

The main operational criteria for relays such as number of cycles, switching frequency, ambient conditions, reliability requirements, load type, switch-on current, load switch-off energy must be clarified in order to ensure reliable operation and long service life.

Example

If the number of cycles is expected to exceed several 100.000 operations per year (e.g. clock generators, fast running machines), an electronic solution is no doubt more appropriate, although we also offer solutions for this type of application. In AC applications crosstalk caused by long control leads is often a problem and can result in constant humming of the relay or even inadvertent triggering due to interference.

Different harmless loads may lead to very high switch-on currents or switch-off energy values, resulting in an unacceptable reduction in service life. Particularly tricky are DC inductive loads.

Characteristics of various loads:

Heating circuits

No higher switch-on currents, no higher switch-off loads.

Incandescent lamps, halogen lamps

Switch-on currents during a few ms in the range 10 ... 18 x rated. Switch-off at rated load.

Low-energy lamps

Very high, but very short switch-on currents due to built-in decoupling capacitors. Contacts have a tendency to fuse.

Transformers, AC contactors





Switching on during zero-transition may lead to switch-on currents of 8 ... 15 x rated values. High inductive switch-off energy is possible. The load must be connected.

Relays









Select the correct Relay

- Level of switching current and voltage of the application?

- DC or AC switching?
- Inductive or capacitive load?
- Expected number of switching cycles?

Symbol	Voltage	Current	Use	Type	Material
 Signal relays	100 mV...5V	10 µA...1 mA	Low-level signals, Standard signals (0...10 V / 4...20 mA)	Gold-plated double contact	AgNi + Au
				Gold-plated Single Contact	AgNi + Au
 Control relays	5V...30V	1 mA...100 mA	PLC inputs, Control circuits	double contact	AgNi
				Gold-plated Single Contact	AgNi + Au
			Frequent, rapid switching procedures	Semiconductor	MOSFET (DC) Triac (AC)
 Power relays	30V...400V	100 mA...16A	Increased AC or DC loads	Single Contact	AgNi
			Electromagnets (utilisation cat. AC-15 / DC-13)	Single Contact	AgSnO ₂
			Frequent, rapid switching procedures, high reliability, noiseless switching	Semiconductor	MOSFET (DC) Triac (AC)
 High-power relays	12V...400V	100 mA...16A	Capacitive loads	Early make contact	AgNi + W AgSnO ₂ + W
			High DC loads, inductive loads	Series contacts	AgNi AgSnO ₂
			Frequent, rapid switching procedures, high reliability, noiseless switching	Semiconductor	MOSFET (DC) Triac (AC)

2 SSR socket mounted

	Type	Pin	Page
CSS Series / R10 Series			
1 pole normally open solid state AC faston	CSS-I		12
1 pole normally open solid state AC faston	R10-Z1I		13
1 pole normally open solid state AC faston	CSS-Z		14
1 pole normally open solid state AC faston	R10-Z1Z		15
1 pole normally open solid state DC faston	CSS-N		16
1 pole normally open solid state DC faston	R10-Z1N		17
1 pole normally open solid state DC faston	CSS-P		18
1 pole normally open solid state DC faston	R10-Z1P		19
CRINT Series			
1 pole normally open solid state DC	CRINT-C1x5		20
1 pole normally open solid state DC	CRINT-C135R		21
1 pole normally open solid state AC	CRINT-C1x8		22
1 pole normally open solid state AC	CRINT-C138R		23

CSS-I

1 pole | normally open solid state AC | faston



Main circuit

Available contact materials	Triac
Recommended minimum contact load	35 mA
Rated load	3 A
Inrush current	150 A, 10 ms
AC load	750 VA

Control circuit

Nominal voltage	see table product references
Operating voltage range	5 ... 48 V DC
Input voltage range	4.75 ... 60 V DC
Input current	10 mA
Pick-up voltage	5 V DC
Release voltage	< 4.75 V
Power consumption DC	300 mW

Output current

Type	Instantaneous
Maximum output current	3 A
Minimum output current	35 mA
Output voltage range	24 ... 250 V AC
Residual current	1 mA
I ² t value	210 A ² s
Maximum voltage drop	≤ 1.1 V AC

General data

Ambient temperature storage (no ice)	-40 ... 85 °C
Ambient temperature operation	-40 ... 70 °C
Pick-up time	0.06 ms
Release time	0.06 ms
Protection degree	IP 40
Dimension	fig. 3.
Weight	28 g
Housing material	PA / PC

Product reference

Description	Type	5-48
DC	CSS-I12X/DC...V	✓

«...» List coil voltage to complete product references

Accessories

Socket	S10, S10-P, S10-PI
--------	--------------------



fig. 1. Wiring diagram

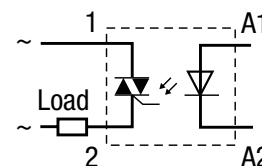


fig. 2. AC derating curve

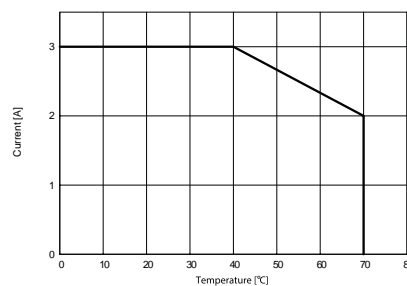
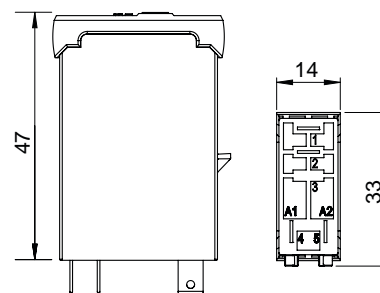


fig. 3. Dimension (mm)



Technical approvals, conformities

Standards IEC/EN 60947

Approvals

R10-Z1I

1 pole | normally open solid state AC | faston

Main circuit

Available contact materials	Triac
Recommended minimum contact load	35 mA
Rated load	3 A
Inrush current	150 A, 10 ms
AC load	750 VA

Control circuit

Nominal voltage	see table product references
Operating voltage range	5 ... 48 V DC
Input voltage range	4.75 ... 60 V DC
Input current	10 mA
Pick-up voltage	5 V DC
Release voltage	< 4.75 V
Power consumption DC	300 mW

Output current

Type	Instantaneous
Maximum output current	3 A
Minimum output current	35 mA
Output voltage range	24 ... 250 V AC
Residual current	1 mA
I^2t value	210 A ² s
Maximum voltage drop	≤ 1.1 V AC

General data

Ambient temperature storage (no ice)	-40 ... 85 °C
Ambient temperature operation	-40 ... 70 °C
Pick-up time	0.06 ms
Release time	0.06 ms
Protection degree	IP 40
Dimension	fig. 3.
Weight	28 g
Housing material	PA

Product reference

Description	Type	5-48
DC	R10-Z1IX/DC...V	✓

«...» List coil voltage to complete product references

Accessories

Socket	S10-GR, S10-PIR
--------	-----------------



fig. 1. Wiring diagram

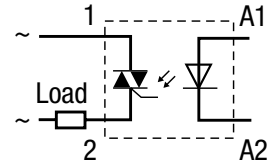


fig. 2. AC derating curve

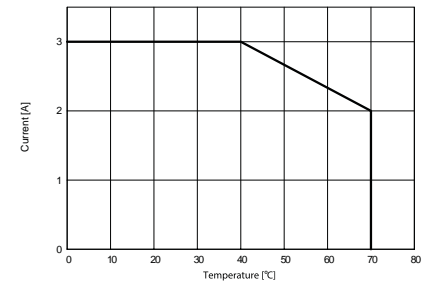
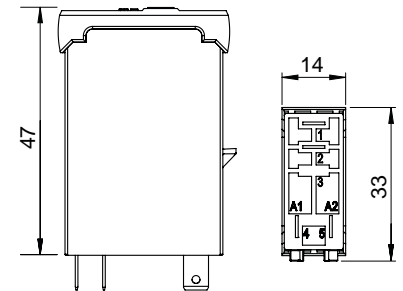


fig. 3. Dimension (mm)



Technical approvals, conformities

Standards IEC/EN 60947;
 Railway standards EN 50155; EN 45545-2

Approvals

CSS-Z

1 pole | normally open solid state AC | faston



Main circuit

Available contact materials	Triac
Recommended minimum contact load	35 mA
Rated load	3 A
Inrush current	150 A, 10 ms
AC load	750 VA

Control circuit

Nominal voltage	see table product references
Operating voltage range	5 ... 48 V DC
Input voltage range	4.75 ... 60 V DC
Input current	10 mA
Pick-up voltage	5 V DC
Release voltage	< 4.75 V
Power consumption DC	300 mW

Output current

Type	Synchronized zero
Maximum output current	3 A
Minimum output current	35 mA
Output voltage range	24 ... 250 V AC
Residual current	1 mA
I ² t value	210 A ² s
Maximum voltage drop	≤ 1.1 V AC

General data

Ambient temperature storage (no ice)	-40 ... 85 °C
Ambient temperature operation	-40 ... 70 °C
Pick-up time	10 ms
Release time	10 ms
Protection degree	IP 40
Dimension	fig. 3.
Weight	28 g
Housing material	PA / PC

Product reference

Description	Type	5-48
DC	CSS-Z12X/DC...V	✓

«...» List coil voltage to complete product references

Accessories

Socket	S10, S10-P, S10-PI
--------	--------------------



fig. 1. Wiring diagram

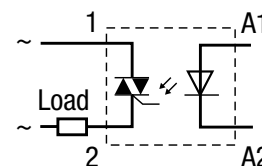


fig. 2. AC derating curve

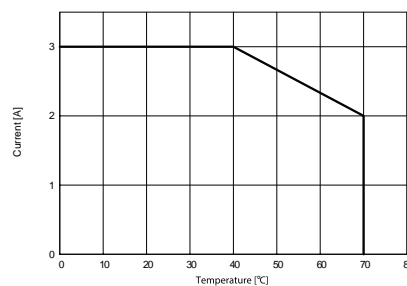
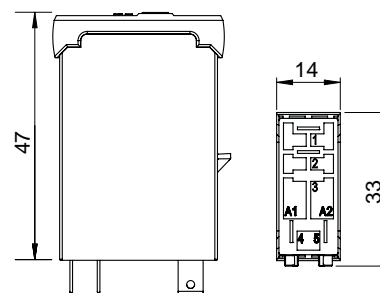


fig. 3. Dimension (mm)



Technical approvals, conformities

Standards IEC/EN 60947



Approvals

2 Solid State Relays socket mounted

R10-Z1Z

1 pole | normally open solid state AC | faston

Main circuit

Available contact materials	  Triac
Recommended minimum contact load	35 mA
Rated load	3 A
Inrush current	150 A, 10 ms
AC load	750 VA

Control circuit

Nominal voltage	see table product references
Operating voltage range	5 ... 48 V DC
Input voltage range	4.75 ... 60 V DC
Input current	10 mA
Pick-up voltage	5 V DC
Release voltage	< 4.75 V
Power consumption DC	300 mW

Output current

Type	Synchronized zero
Maximum output current	3 A
Minimum output current	35 mA
Output voltage range	24 ... 250 V AC
Residual current	1 mA
I^2t value	210 A ² s
Maximum voltage drop	≤ 1.1 V AC

General data

Ambient temperature storage (no ice)	-40 ... 85 °C
Ambient temperature operation	-40 ... 70 °C
Pick-up time	10 ms
Release time	10 ms
Protection degree	IP 40
Dimension	fig. 3.
Weight	28 g
Housing material	PA

Product reference

Description	Type	5-48
DC	R10-Z1ZX/DC...V	✓

«...» List coil voltage to complete product references

Accessories

Socket	S10-GR, S10-PIR
--------	-----------------



fig. 1. Wiring diagram

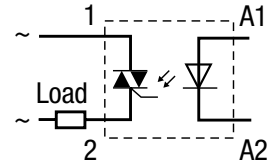


fig. 2. AC derating curve

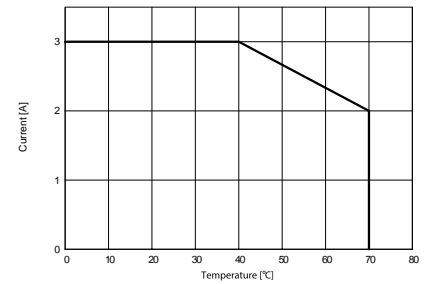
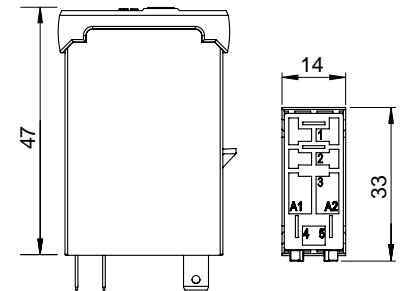



fig. 3. Dimension (mm)



Technical approvals, conformities

Standards IEC/EN 60947;
 Railway standards EN 50155; EN 45545-2

Approvals 

CSS-N

1 pole | normally open solid state DC | faston

Main circuit

Available contact materials	MOSFET
Recommended minimum contact load	1 mA
Rated load	6 A
Inrush current	40 A, 10 ms
DC load	360 W

Control circuit

Nominal voltage	see table product references
Operating voltage range	5 ... 48 V DC
Input voltage range	4.75 ... 60 V DC
Input current	4 mA
Pick-up voltage	5 V DC
Release voltage	< 4.75 V
Power consumption DC	300 mW

Output current

Type	Instantaneous
Logic	NPN
Maximum output current	6 A
Minimum output current	1 mA
Output voltage range	5 ... 48 V DC
Residual current	0.1 mA
Maximum voltage drop	≤ 0.14 V DC

General data

Ambient temperature storage (no ice)	-40 ... 85 °C
Ambient temperature operation	-40 ... 70 °C
Pick-up time	0.06 ms
Release time	0.06 ms
Protection degree	IP 40
Dimension	fig. 3.
Weight	28 g
Housing material	PA / PC

Product reference

Description	Type	5-48
DC	CSS-N13X/DC...V	✓

«...» List coil voltage to complete product references

Accessories

Socket	S10, S10-P, S10-PI
--------	--------------------



fig. 1. Wiring diagram

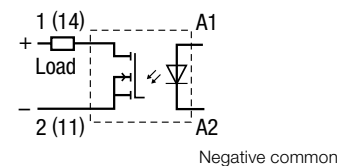


fig. 2. DC derating curve

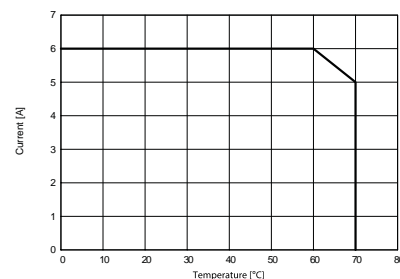
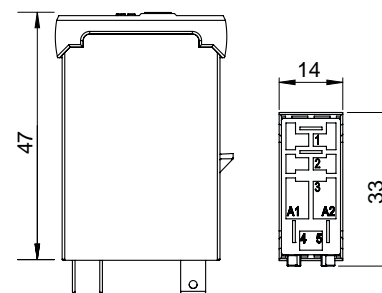


fig. 3. Dimension (mm)



Technical approvals, conformities

Standards IEC/EN 60947


Approvals

2 Solid State Relays socket mounted

R10-Z1N

1 pole | normally open solid state DC | faston

Main circuit

Available contact materials	 MOSFET
Recommended minimum contact load	1 mA
Rated load	6 A
Inrush current	40 A, 10 ms
DC load	360 W

Control circuit

Nominal voltage	see table product references
Operating voltage range	5 ... 48 V DC
Input voltage range	4.75 ... 60 V DC
Input current	4 mA
Pick-up voltage	5 V DC
Release voltage	< 4.75 V
Power consumption DC	300 mW

Output current

Type	Instantaneous
Logic	NPN
Maximum output current	6 A
Minimum output current	1 mA
Output voltage range	5 ... 48 V DC
Residual current	0.1 mA
Maximum voltage drop	≤ 0.14 V DC

General data

Ambient temperature storage (no ice)	-40 ... 85 °C
Ambient temperature operation	-40 ... 70 °C
Pick-up time	0.06 ms
Release time	0.06 ms
Protection degree	IP 40
Dimension	fig. 3.
Weight	28 g
Housing material	PA

Product reference

Description	Type	5-48
DC	R10-Z1NX/DC...V	✓

«...» List coil voltage to complete product references

Accessories

Socket	S10-GR, S10-PIR
--------	-----------------



fig. 1. Wiring diagram

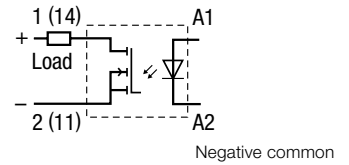


fig. 2. DC derating curve

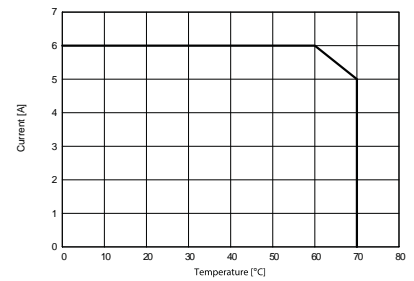
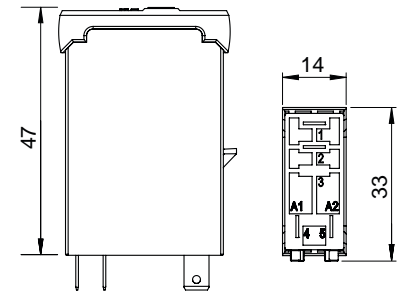


fig. 3. Dimension (mm)



Technical approvals, conformities

Standards IEC/EN 60947;
 Railway standards EN 50155; EN 45545-2

Approvals 

CSS-P

1 pole | normally open solid state DC | faston

Main circuit

Available contact materials	MOSFET
Recommended minimum contact load	1 mA
Rated load	6 A
Inrush current	40 A, 10 ms
DC load	360 W

Control circuit

Nominal voltage	see table product references
Operating voltage range	5 ... 48 V DC
Input voltage range	4.75 ... 60 V DC
Input current	4 mA
Pick-up voltage	5 V DC
Release voltage	< 4.75 V
Power consumption DC	300 mW

Output current

Type	Instantaneous
Logic	PNP
Maximum output current	6 A
Minimum output current	1 mA
Output voltage range	5 ... 48 V DC
Residual current	0.1 mA
Maximum voltage drop	≤ 0.14 V DC

General data

Ambient temperature storage (no ice)	-40 ... 85 °C
Ambient temperature operation	-40 ... 70 °C
Pick-up time	0.06 ms
Release time	0.06 ms
Protection degree	IP 40
Dimension	fig. 3.
Weight	28 g
Housing material	PA / PC

Product reference

Description	Type	5-48
DC	CSS-P13X/DC...V	✓

«...» List coil voltage to complete product references

Accessories

Socket	S10, S10-P, S10-PI
--------	--------------------



fig. 1. Wiring diagram

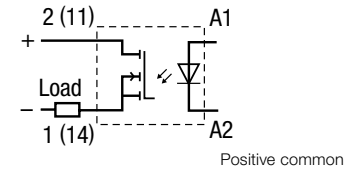


fig. 2. DC derating curve

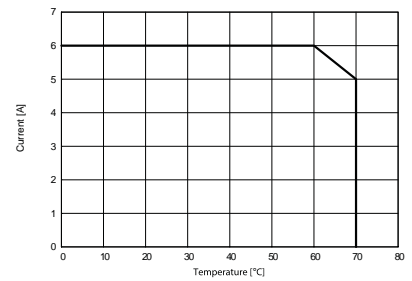
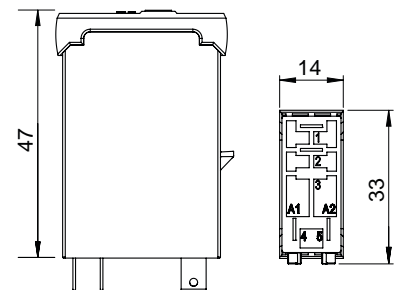


fig. 3. Dimension (mm)



Technical approvals, conformities

Standards IEC/EN 60947


Approvals

2 Solid State Relays socket mounted

R10-Z1P

1 pole | normally open solid state DC | faston

Main circuit

Available contact materials	 MOSFET
Recommended minimum contact load	1 mA
Rated load	6 A
Inrush current	40 A, 10 ms
DC load	360 W

Control circuit

Nominal voltage	see table product references
Operating voltage range	5 ... 48 V DC
Input voltage range	4.75 ... 60 V DC
Input current	4 mA
Pick-up voltage	5 V DC
Release voltage	< 4.75 V
Power consumption DC	300 mW

Output current

Type	Instantaneous
Logic	PNP
Maximum output current	6 A
Minimum output current	1 mA
Output voltage range	5 ... 48 V DC
Residual current	0.1 mA
Maximum voltage drop	≤ 0.14 V DC

General data

Ambient temperature storage (no ice)	-40 ... 85 °C
Ambient temperature operation	-40 ... 70 °C
Pick-up time	0.06 ms
Release time	0.06 ms
Protection degree	IP 40
Dimension	fig. 3.
Weight	28 g
Housing material	PA

Product reference

Description	Type	5-48
DC	R10-Z1PX/DC...V	✓

«...» List coil voltage to complete product references

Accessories

Socket	S10-GR, S10-PIR
--------	-----------------



fig. 1. Wiring diagram

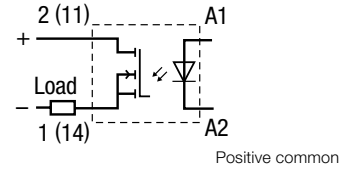


fig. 2. DC derating curve

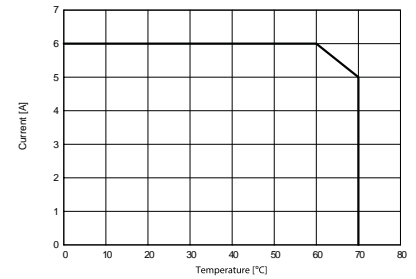
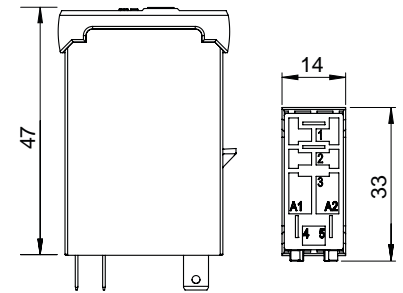


fig. 3. Dimension (mm)



Technical approvals, conformities

Standards IEC/EN 60947;
 Railway standards EN 50155; EN 45545-2

Approvals 

CRINT-C1x5

1 pole | normally open solid state DC



Main circuit

Available contact materials	MOSFET
Recommended minimum contact load	20 mA / 5 V
Rated load	4 A
Inrush current	48 A, 10 ms
DC load	115 W

Control circuit

Nominal voltage	see table product references
Operating voltage range	0.8 ... 1.2 U _N
Pick-up voltage	≤ 0.8 U _N
Release voltage	≤ 0.25 U _N
Power consumption DC	160 mW

Insulation

Test voltage open contact	1 kV / 1 min
Test voltage contact / coil	2.5 kV / 1 min
Pollution degree	3
Overvoltage category	III

Output current

Type	Instantaneous
Maximum output current	4 A
Minimum output current	20 mA
Output voltage range	3 ... 28.8 V DC
Residual current	0.1 mA
Maximum voltage drop	0.35 V DC

General data

Ambient temperature storage (no ice)	-30 ... 85 °C
Ambient temperature operation	-30 ... 70 °C
Pick-up time	1 ms
Release time	1 ms
Conductor cross section screw terminal	2.5 mm ²
Conductor cross section spring cage	0.75 ... 2.5 mm ²
Protection degree	IP 20
Mounting	TH 35 (EN 60715)
Dimension	fig. 3.
Weight	30 g
Housing material	PA

Product reference

Description	Type	12	24	48	60	110-125	220-240
Screw terminal	CRINT-C115/DC...V	✓	✓	✓	✓	✓	✓
Cage clamp terminal	CRINT-C125/DC...V	✓	✓	✓	✓	✓	✓
Push-in	CRINT-C135/DC...V	✓	✓	✓	✓	✓	✓

«...» List coil voltage to complete product references

Accessories

Jumper link	blue:	CRINT-BR20-BU (BAG 5 PCS)
	red:	CRINT-BR20-RD (BAG 5 PCS)
	black:	CRINT-BR20-BK (BAG 5 PCS)
Label plate		CRINT-LAB (BAG 4x16 PCS)
Spacer		CRINT-SEP (BAG 5 PCS)
Label strip (for push-in only)		BS11-PI (50m)

Replacement relays

Description	Type	12	24	48	60 *
DC	CRINT-R15/DC...V	✓	✓	✓	✓

«...» List coil voltage to complete product references

*60 V relay used for all sockets with a nominal voltage higher or equal 60 V



fig. 1. Wiring diagram

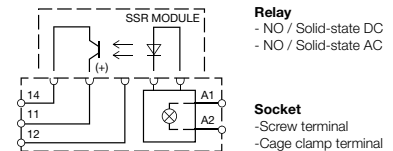


fig. 2. DC load limit curve

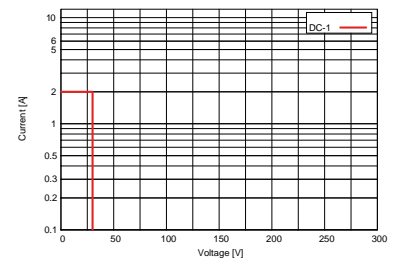
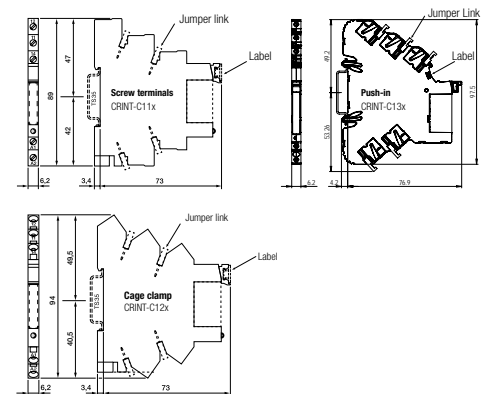


fig. 3. Dimension (mm)



Technical approvals, conformities

Standards IEC/EN 61810

Approvals

CRINT-C115 & CRINT-C125 only

2 Solid State Relays socket mounted

CRINT-C135R

1 pole | normally open solid state DC

Main circuit

Available contact materials	MOSFET
Recommended minimum contact load	20 mA / 5 V
Rated load	4 A
Inrush current	48 A, 10 ms
DC load	115 W

Control circuit

Nominal voltage	see table product references
Operating voltage range	0.8 ... 1.2 U _N
Pick-up voltage	≤ 0.8 U _N
Release voltage	≤ 0.25 U _N
Power consumption DC	160 mW

Insulation

Test voltage open contact	1 kV / 1 min
Test voltage contact / coil	2.5 kV / 1 min
Pollution degree	3
Overvoltage category	III

Output current

Type	Instantaneous
Maximum output current	4 A
Minimum output current	20 mA
Output voltage range	3 ... 28.8 V DC
Residual current	0.1 mA
Maximum voltage drop	0.35 V DC

General data

Ambient temperature storage (no ice)	-30 ... 85 °C
Ambient temperature operation	-30 ... 70 °C
Pick-up time	1 ms
Release time	1 ms
Conductor cross section screw terminal	2.5 mm ²
Conductor cross section spring cage	0.75 ... 2.5 mm ²
Protection degree	IP 20
Mounting	TH 35 (EN 60715)
Dimension	fig. 3.
Weight	30 g
Housing material	PA

Product reference

Description	Type	12	24	48	60	110-125	220-240
Push-in	CRINT-C135R/DC...V	✓	✓	✓	✓	✓	✓

«...» List coil voltage to complete product references

Accessories

Jumper link	blue: CRINT-BR20-BU (BAG 5 PCS)
	red: CRINT-BR20-RD (BAG 5 PCS)
	black: CRINT-BR20-BK (BAG 5 PCS)
Label plate	CRINT-LAB (BAG 4x16 PCS)
Spacer	CRINT-SEP (BAG 5 PCS)
Label strip	BS11-PI (50m)

Replacement relays

Description	Type	12	24	48	60 *
DC	CRINT-R15/DC...V	✓	✓	✓	✓

«...» List coil voltage to complete product references

*60 V relay used for all sockets with a nominal voltage higher or equal 60 V



fig. 1. Wiring diagram

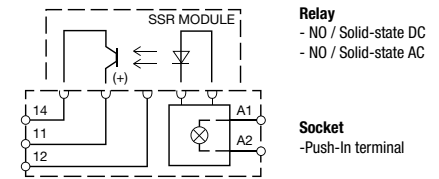


fig. 2. DC load limit curve

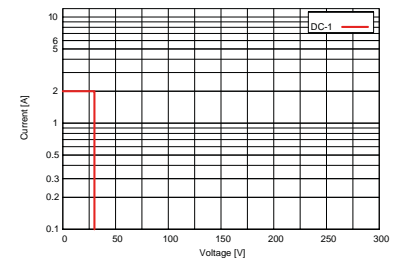
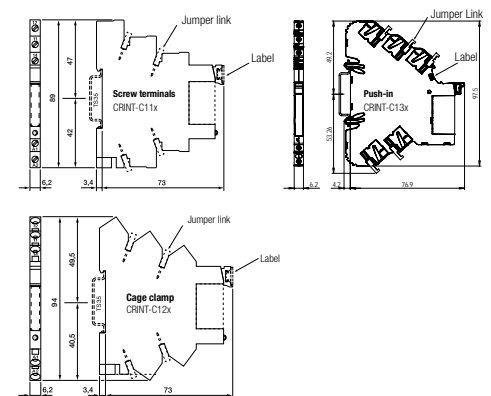


fig. 3. Dimension (mm)



Technical approvals, conformities

Standards IEC/EN 61810;
 Railway standards EN 50155; EN 45545-2

Approvals

CRINT-C1x8

1 pole | normally open solid state AC



Main circuit

Available contact materials	Triac
Recommended minimum contact load	20 mA / 5 V
Rated load	2 A
Inrush current	80 A, 10 ms
AC load	fig. 2.

Control circuit

Nominal voltage	see table product references
Operating voltage range	0.8 ... 1.2 U _N
Pick-up voltage	≤ 0.8 U _N
Release voltage	≤ 0.25 U _N
Power consumption DC	150 mW

Insulation

Test voltage open contact	1 kV / 1 min
Test voltage contact / coil	2.5 kV / 1 min
Pollution degree	3
Overvoltage category	III

Output current

Type	Synchronized zero
Maximum output current	2 A
Minimum output current	100 mA
Output voltage range	48 ... 280 V AC
Residual current	1.5 mA
Maximum voltage drop	1.2 V AC

General data

Ambient temperature storage (no ice)	-30 ... 85 °C
Ambient temperature operation	-30 ... 70 °C
Pick-up time	1 ms
Release time	1 ms
Conductor cross section screw terminal	2.5 mm ²
Conductor cross section spring cage	0.75 ... 2.5 mm ²
Protection degree	IP 20
Mounting	TH 35 (EN 60715)
Dimension	fig. 3.
Weight	30 g
Housing material	PA

Product reference

Description	Type	12	24	60	110-125	220-240
Screw terminal	CRINT-C118/DC...V	✓	✓	✓	✓	✓
Cage clamp terminal	CRINT-C128/DC...V	✓	✓	✓	✓	✓
Push-in	CRINT-C138/DC...V	✓	✓	✓	✓	✓

«...» List coil voltage to complete product references

Accessories

Jumper link	blue:	CRINT-BR20-BU (BAG 5 PCS)
	red:	CRINT-BR20-RD (BAG 5 PCS)
	black:	CRINT-BR20-BK (BAG 5 PCS)
Label plate		CRINT-LAB (BAG 4x16 PCS)
Spacer		CRINT-SEP (BAG 5 PCS)
Label strip (for push-in only)		BS11-PI (50m)

Replacement relays

Description	Type	12	24	60 *
DC	CRINT-R18/DC...V	✓	✓	✓

«...» List coil voltage to complete product references

*60 V relay used for all sockets with a nominal voltage higher or equal 60 V



fig. 1. Wiring diagram

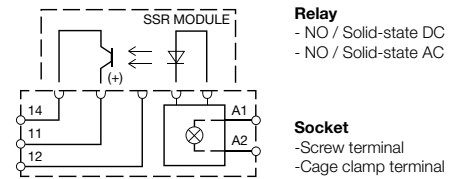


fig. 2. AC load limit curve

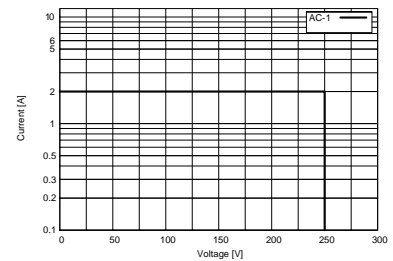
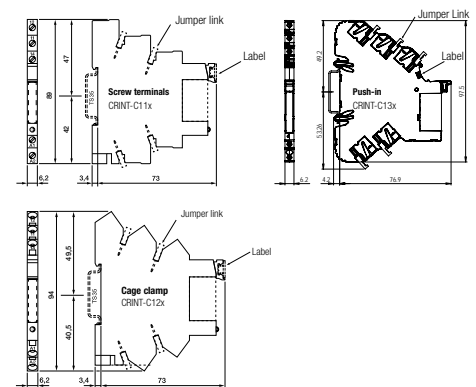


fig. 3. Dimension (mm)



Technical approvals, conformities

Standards IEC/EN 61810

Approvals

CRINT-C118 & CRINT-C128 only

2 Solid State Relays socket mounted

CRINT-C138R

1 pole | normally open solid state AC

Main circuit

Available contact materials	Triac
Recommended minimum contact load	20 mA / 5 V
Rated load	2 A
Inrush current	80 A, 10 ms
AC load	fig. 2.

Control circuit

Nominal voltage	see table product references
Operating voltage range	0.8 ... 1.2 U _N
Pick-up voltage	≤ 0.8 U _N
Release voltage	≤ 0.25 U _N
Power consumption DC	150 mW

Insulation

Test voltage open contact	1 kV / 1 min
Test voltage contact / coil	2.5 kV / 1 min
Pollution degree	3
Overtoltage category	III

Output current

Type	Synchronized zero
Maximum output current	2 A
Minimum output current	100 mA
Output voltage range	48 ... 280 V AC
Residual current	1.5 mA
Maximum voltage drop	1.2 V AC

General data

Ambient temperature storage (no ice)	-30 ... 85 °C
Ambient temperature operation	-30 ... 70 °C
Pick-up time	1 ms
Release time	1 ms
Conductor cross section screw terminal	2.5 mm ²
Conductor cross section spring cage	0.75 ... 2.5 mm ²
Protection degree	IP 20
Mounting	TH 35 (EN 60715)
Dimension	fig. 3.
Weight	30 g
Housing material	PA

Product reference

Description	Type	12	24	60	110-125	220-240
Push-in	CRINT-C138R/DC...V	✓	✓	✓	✓	✓

«...» List coil voltage to complete product references

Accessories

Jumper link	blue: CRINT-BR20-BU (BAG 5 PCS) red: CRINT-BR20-RD (BAG 5 PCS) black: CRINT-BR20-BK (BAG 5 PCS)
Label plate	CRINT-LAB (BAG 4x16 PCS)
Spacer	CRINT-SEP (BAG 5 PCS)
Label strip	BS11-PI (50m)

Replacement relays

Description	Type	12	24	60 *
DC	CRINT-R18/DC...V	✓	✓	✓

«...» List coil voltage to complete product references

*60 V relay used for all sockets with a nominal voltage higher or equal 60 V



fig. 1. Wiring diagram

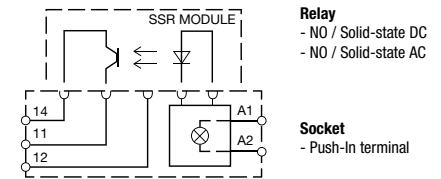


fig. 2. AC load limit curve

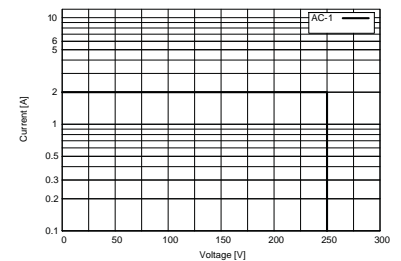
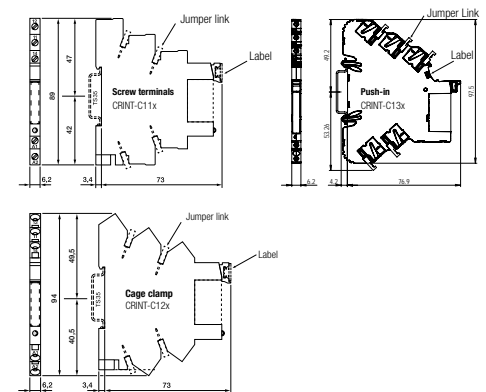


fig. 3. Dimension (mm)



Technical approvals, conformities

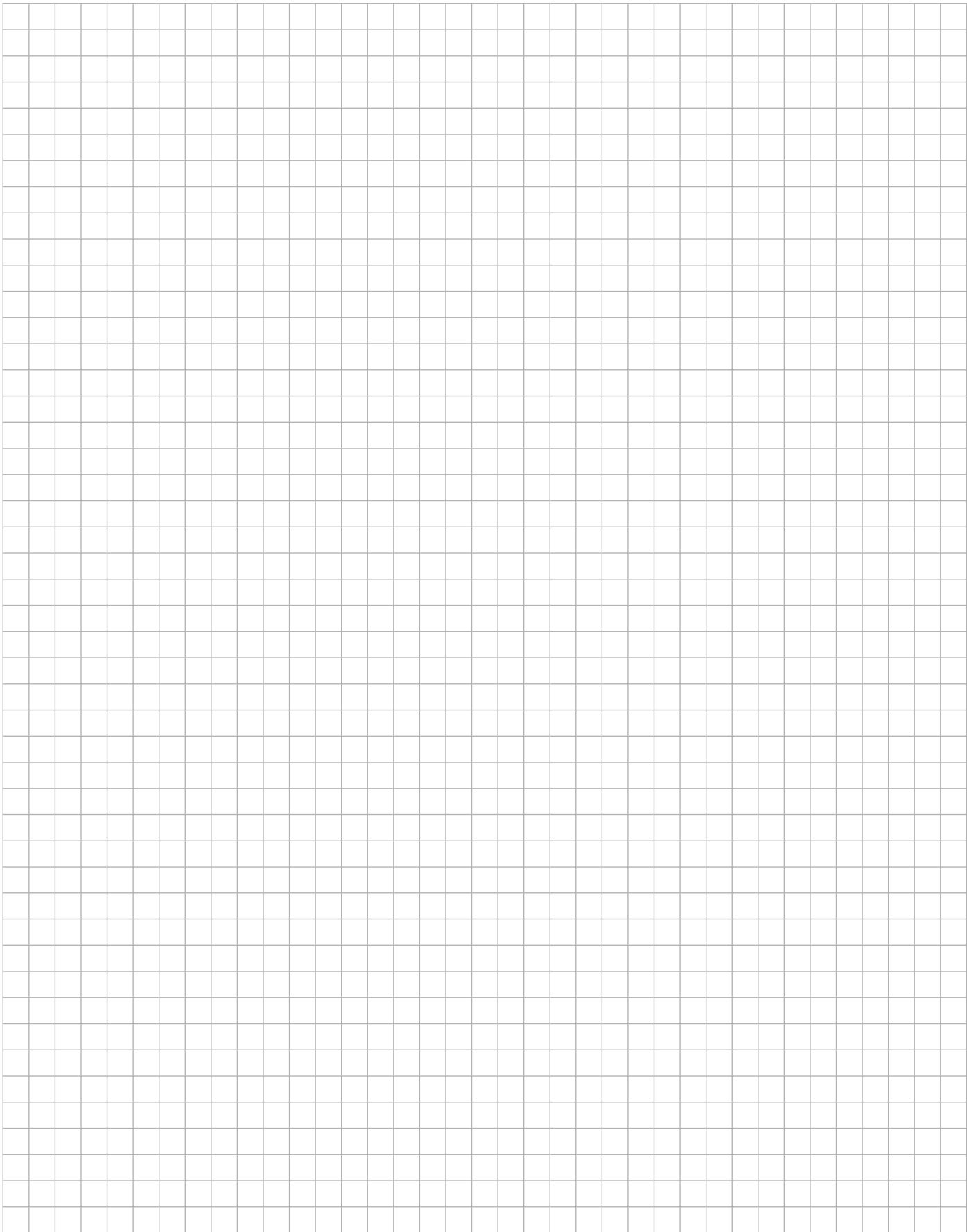
Standards IEC/EN 61810;
Railway standards EN 50155; EN 45545-2

Approvals

3 SSR panel or DIN rail mounted

Chapter	Page
3.1 Overview	27
3.2 SP1M	29
3.3 SP1P	39
3.4 Accessories	79

Notes

A large rectangular area filled with a fine grid of small squares, intended for writing notes or technical diagrams.

3.1 SSR / Overview

Chapter	Page
3.1 Overview	28

SP product key

Main parameters					Control			Output parameters				Control parameters			
1	2	3	4	5	6	7	8	9	10	11	12	13	14		
SP	1	M	X	F	-	T	Z	X	0600	V	025	X	/	DC	24V

1. Solid State Relay

SP = Solid state Panel mounting

2. Channels

- 1 = Single-channel relay
- 2 = Two-channel relay
- 3 = Three-channel relay

3. Size H x W x D (mm)

- M = 38.5 x 28.5 x max. 25.2
- P = 58.6 x 45.7 x max. 33.5
- ... = other series

4. Free Key

X

5. Terminals / IP Protection

- F = Faston / IP00
- L = Faston large / IP00
- S = Screw / IP20
- N = Screw / IP00

6. Semiconductor type

- T = Triac / SCR (AC)
- M = MOSFET (DC)
- I = IGBT (DC)
- R = Transistor (DC)

7. Logic

- Z = Zero-crossing (AC)
- I = Random-on, Instantaneous (AC)
- N = NPN, Instantaneous (DC)
- P = PNP, Instantaneous (DC)
- Q = Zero crossing / PNP (AC)
- S = Zero crossing, NPN (AC)

8. Free key

X

9. Output circuit rated voltage

- 0030 = 30 V
- ⋮
- 0250 = 250 V
- ⋮
- 1200 = 1200 V

10. Surge protection

- N = RC protection
- V = Varistor and RC
- T = Transient voltage suppressor and RC

11. Output circuit current

- 001 = 1 A
- ⋮
- 025 = 25 A
- ⋮
- 125 = 125 A

12. Indication

- N = No LED
- X = LED
- A = Alarm output
- B = LED and alarm output

13. Control circuit voltage

- AC = AC Voltage
- DC = DC Voltage
- UC = UC Voltage

14. Control circuit rated voltage

- 4–15 V
- ⋮
- 48 V
- ⋮
- 600 V

General information

General remarks

As any solid state relays, they don't provide a galvanic insulation between the load and the mains. Therefore the solid state relay must be always used in conjunction with an adequate circuit breaker with insulation performances or a similar device, in order to ensure a reliable insulation in case of malfunction or when the relay must be insulated from the mains (eg. due to maintenance).

Each solid state relay can be DIN-Rail mounted as soon as a specific heatsink is used.

Mounting

The heat generated by the relay must be removed through its entire bottom plate. Therefore an adequate heat exchanger (either any of the recommended heatsinks listed in the datasheets under "heatsinks" or an equivalent product) must be firmly fixed to the solid state relay bottom plate.

ComatReleco's heatsink offering consists of 2 clusters:

- DIN rail mounted heatsinks (through a DIN rail clip, supplied with the product)
- Panel mounted heatsinks (by means of screws)

Between the solid state relay bottom plate and the heat exchanger either the conducting pad or the conducting grease (refer to 'accessories' in the datasheets) must be added.

Each terminal connector of the relay must be firmly fixed to the electric cables, to avoid that loose wiring leads to abnormal heating and thus to product damages and malfunctionings. The recommended mounting torques for the terminals are 0.58-0.98 Nm, 0.98-1.37 Nm respectively for M3 and M4 terminals.

Overvoltage protection

The overvoltage protection of the solid state relay can be increased by choosing either (refer under 'product reference' in the datasheets):

- **MOV** (Metal Oxide Varistor) option or
- **TVS** (Transient Voltage Suppressor) option

In case of an overvoltage, **MOV** clamps it by shunting through itself, where **TVS** triggers the solid state relay.

When selecting any of those options by ordering, the delivered product will include the specified feature, no further wiring will be necessary.

The improved protection levels are stated in the specific datasheet.

3.2 SSR / SP1M

	Type	Page
1 phase normally open solid state AC up to 280V, 25A synchr zero Faston IP 00	SP1MXF-TZX0240	30
1 phase normally open solid state AC up to 280V, 25A instantaneous Faston IP 00	SP1MXF-TIX0240	31
1 phase normally open solid state AC up to 280V, 25A synchr zero Screw IP 00	SP1MXN-TZX0240	32
1 phase normally open solid state AC up to 280V, 25A instantaneous Screw IP 00	SP1MXN-TIX0240	33
1 phase normally open solid state AC up to 440V, 25A synchr zero Faston IP 00	SP1MXF-TZX0380	34
1 phase normally open solid state AC up to 440V, 25A instantaneous Faston IP 00	SP1MXF-TIX0380	35
1 phase normally open solid state AC up to 440V, 25A synchr zero Screw IP 00	SP1MXN-TZX0380	36
1 phase normally open solid state AC up to 440V, 25A instantaneous Screw IP 00	SP1MXN-TIX0380	37
1 phase normally open solid state AC up to 440V, 25A instantaneous Screw IP 00	SP1MXN-TIX0380	38

SP1MXF-TZX0240



1 phase | normally open solid state AC up to 280V, 25A | synchr zero | Faston IP 00

Main circuit

Output type	⚡ Triac		
Type	Synchronized zero		
Rated voltage AC	240		
Output voltage range AC	24 ... 280 V		
Operating frequency	47 ... 63 Hz		
Recommended minimum contact load	100 mA		
Maximum leakage current @ rated voltage A	5 mA		
Maximum voltage drop @ rated current	≤ 1.5 V rms		
Repetitive peak voltage in off-state	600 Vpk		
Maximum off state dv / dt	200 V / μs		
Maximum non repetitive di / dt	50 A/μs		
Contact type	Faston		
Contact	1 NO		
Load current	10 A	16 A	25 A
Thermal derating, refer to:	fig. 2.	fig. 3.	fig. 4.
Inrush current @ 10 ms	120 A	160 A	250 A
I ² t @ 10 ms	50 A ² s	128 A ² s	312 A ² s

Control circuit

Operating voltage range	4 ... 32 V DC
Maximum input current @ maximum operating voltage	25 mA
Pick-up voltage	4 V DC
Release voltage	1 V DC
Power consumption DC	0.8 W

Insulation

Rated test voltage input/output	4000 Vrms / 1 min
Rated test voltage input output/base	2500 Vrms / 1 min
Overtoltage cathegory	III

General data

Ambient temperature storage (no ice)	-30 ... 100 °C
Ambient temperature operation	-30 ... 80 °C
Pick-up time	10 ms
Release time	10 ms
Power Factor	> 0.5
Protection degree	IP 00
Dimension	fig. 5.
Weight	35 g
Housing material	PBT

Product reference (o.r. = on request)

Description	Type	A		
		010	016	025
DC Control				
1 NO, LED, RC Protection	SP1MXF-TZX0240N...X/DC4-32V	✓	o.r.	✓
1 NO, LED, MOV (*1) and RC protection	SP1MXF-TZX0240V...X/DC4-32V	o.r.	o.r.	o.r.
1 NO, LED, TVS (*2) and RC protection	SP1MXF-TZX0240T...X/DC4-32V	✓	o.r.	✓

Complete load current to complete product reference

(*1) Maximum operating voltage allowed by MOV: 300 V AC

(*2) TVS protection voltage: 480 V

Heatsinks (to be used either with SP1M/pad or SP1/grease)

Heatsinks	Thermal resistance [°C/W]	Dimensions H x W x D (mm)	Mounting type
HS_003	1.9	81x50x82.5	DIN rail (with clip)
HS_010	2.8	80x32x50	Panel (with screws)
HS_012	2.1	80x50x50	Panel (with screws)
HS_015	0.6	106x80x96	Panel (with screws)
HS_020	1.6	106x50x96	Panel (with screws)

Accessories

Thermal conducting pad	SP1M/pad
Thermal conducting grease	SP1/grease



fig. 1. Wiring diagram

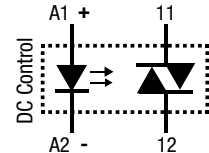


fig. 2. Thermal derating curve 10 A

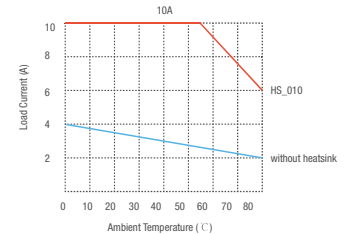


fig. 3. Thermal derating curve 16 A

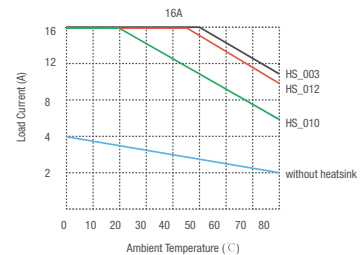


fig. 4. Thermal derating curve 25 A

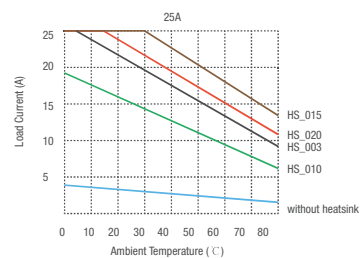
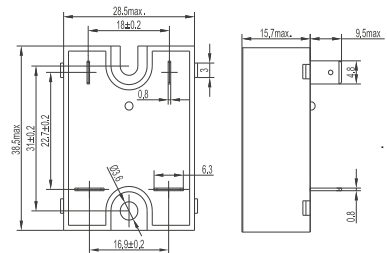


fig. 5. Dimension (mm)



Technical approvals, conformities

Standards EN 60950-1, EN 62314



SP1MXF-TIX0240

1 phase | normally open solid state AC up to 280V, 25A | instantaneous | Faston IP 00



Main circuit

Output type	⚡ Triac		
Type	Instantaneous		
Rated voltage AC	240		
Output voltage range AC	24 ... 280 V		
Operating frequency	47 ... 63 Hz		
Recommended minimum contact load	100 mA		
Maximum leakage current @ rated voltage A	5 mA		
Maximum voltage drop @ rated current	≤ 1.5 V rms		
Repetitive peak voltage in off-state	600 Vpk		
Maximum off state dv / dt	200 V / μs		
Maximum non repetitive di / dt	50 A/μs		
Contact type	Faston		
Contact	1 NO		
Load current	10 A	16 A	25 A
Thermal derating, refer to:	fig. 2.	fig. 3.	fig. 4.
Inrush current @ 10 ms	120 A	160 A	250 A
I ² t @ 10 ms	50 A ² s	128 A ² s	312 A ² s

Control circuit

Operating voltage range	4 ... 32 V DC
Maximum input current @ maximum operating voltage	25 mA
Pick-up voltage	4 V DC
Release voltage	1 V DC
Power consumption DC	0.8 W

Insulation

Rated test voltage input/output	4000 Vrms / 1 min
Rated test voltage input output/base	2500 Vrms / 1 min
Overvoltage category	III

General data

Ambient temperature storage (no ice)	-30 ... 100 °C
Ambient temperature operation	-30 ... 80 °C
Pick-up time	1 ms
Release time	10 ms
Power Factor	> 0.5
Protection degree	IP 00
Dimension	fig. 5.
Weight	35 g
Housing material	PBT

Product reference (o.r. = on request)

Description	Type	A		
		010	016	025
DC Control				
1 NO, LED, RC Protection	SP1MXF-TIX0240N...X/DC4-32V	✓	o.r.	✓
1 NO, LED, MOV (*1) and RC protection	SP1MXF-TIX0240V...X/DC4-32V	o.r.	o.r.	o.r.
1 NO, LED, TVS (*2) and RC protection	SP1MXF-TIX0240T...X/DC4-32V	✓	o.r.	✓

Complete load current to complete product reference

(*1) Maximum operating voltage allowed by MOV: 300 V AC

(*2) TVS protection voltage: 480 V

Heatsinks (to be used either with SP1M/pad or SP1/grease)

Heatsinks	Thermal resistance [°C/W]	Dimensions H x W x D (mm)	Mounting type
HS_003	1.9	81x50x82.5	DIN rail (with clip)
HS_010	2.8	80x32x50	Panel (with screws)
HS_012	2.1	80x50x50	Panel (with screws)
HS_015	0.6	106x80x96	Panel (with screws)
HS_020	1.6	106x50x96	Panel (with screws)

Accessories

Thermal conducting pad	SP1M/pad
Thermal conducting grease	SP1/grease



fig. 1. Wiring diagram

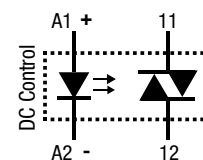


fig. 2. Thermal derating curve 10 A

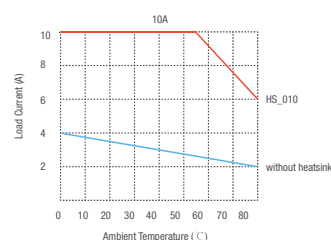


fig. 3. Thermal derating curve 16 A

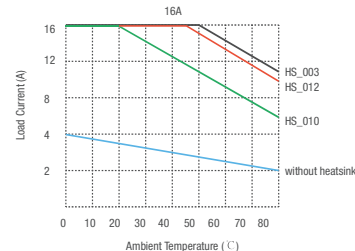


fig. 4. Thermal derating curve 25 A

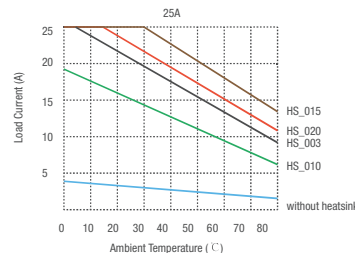
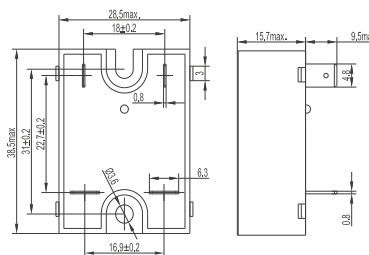


fig. 5. Dimension (mm)



Technical approvals, conformities

Standards EN 60950-1, EN 62314



SP1MXN-TZX0240



1 phase | normally open solid state AC up to 280V, 25A | synchr zero | Screw IP 00

Main circuit

Output type	⚡ Triac		
Type	Synchronized zero		
Rated voltage AC	240		
Output voltage range AC	24 ... 280 V		
Operating frequency	47 ... 63 Hz		
Recommended minimum contact load	100 mA		
Maximum leakage current @ rated voltage A	5 mA		
Maximum voltage drop @ rated current	≤ 1.5 V rms		
Repetitive peak voltage in off-state	600 Vpk		
Maximum off state dv / dt	200 V / μs		
Maximum non repetitive di / dt	50 A/μs		
Contact type	Screw		
Contact	1 NO		
Load current	10 A	16 A	25 A
Thermal derating, refer to:	fig. 2.	fig. 3.	fig. 4.
Inrush current @ 10 ms	120 A	160 A	250 A
I²t @ 10 ms	50 A²s	128 A²s	312 A²s

Control circuit

Operating voltage range	4 ... 32 V DC
Maximum input current @ maximum operating voltage	25 mA
Pick-up voltage	4 V DC
Release voltage	1 V DC
Power consumption DC	0.8 W

Insulation

Rated test voltage input/output	4000 Vrms / 1 min
Rated test voltage input output/base	2500 Vrms / 1 min
Overtoltage category	III

General data

Ambient temperature storage (no ice)	-30 ... 100 °C
Ambient temperature operation	-30 ... 80 °C
Pick-up time	10 ms
Release time	10 ms
Power Factor	> 0.5
Protection degree	IP 00
Dimension	fig. 5.
Weight	35 g
Housing material	PBT

Product reference (o.r. = on request)

Description	Type	A		
		010	016	025
DC Control				
1 NO, LED, RC Protection	SP1MXN-TZX0240N...X/DC4-32V	✓	o.r.	✓
1 NO, LED, MOV (*1) and RC protection	SP1MXN-TZX0240V...X/DC4-32V	o.r.	o.r.	o.r.
1 NO, LED, TVS (*2) and RC protection	SP1MXN-TZX0240T...X/DC4-32V	✓	o.r.	✓

Complete load current to complete product reference

(*1) Maximum operating voltage allowed by MOV: 300 V AC

(*2) TVS protection voltage: 480 V

Heatsinks (to be used either with SP1M/pad or SP1/grease)

Heatsinks	Thermal resistance [°C/W]	Dimensions H x W x D (mm)	Mounting type
HS_003	1.9	81x50x82.5	DIN rail (with clip)
HS_010	2.8	80x32x50	Panel (with screws)
HS_012	2.1	80x50x50	Panel (with screws)
HS_015	0.6	106x80x96	Panel (with screws)
HS_020	1.6	106x50x96	Panel (with screws)

Accessories

Thermal conducting pad	SP1M/pad
Thermal conducting grease	SP1/grease
Transparent cover Can not be removed after assembly	SP1MXN/cover



fig. 1. Wiring diagram

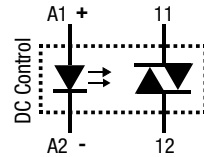


fig. 2. Thermal derating curve 10 A

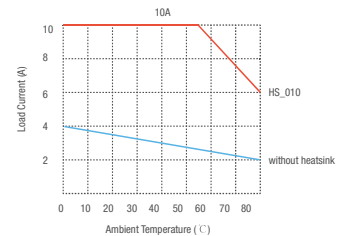


fig. 3. Thermal derating curve 16 A

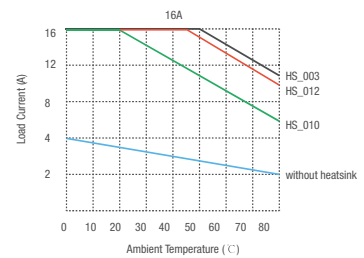


fig. 4. Thermal derating curve 25 A

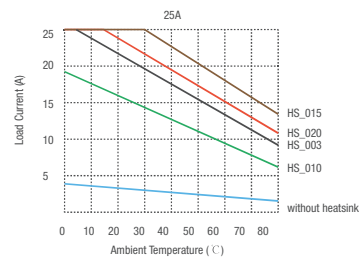
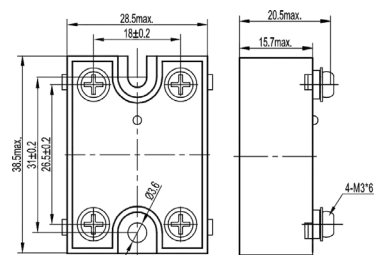


fig. 5. Dimension (mm)



Technical approvals, conformities

Standards EN 60950-1, EN 62314



SP1MXN-TIX0240

1 phase | normally open solid state AC up to 280V, 25A | instantaneous | Screw IP 00



Main circuit

Output type	⚡ Triac		
Type	Instantaneous		
Rated voltage AC	240		
Output voltage range AC	24 ... 280 V		
Operating frequency	47 ... 63 Hz		
Recommended minimum contact load	100 mA		
Maximum leakage current @ rated voltage A	5 mA		
Maximum voltage drop @ rated current	≤ 1.5 V rms		
Repetitive peak voltage in off-state	600 Vpk		
Maximum off state dv / dt	200 V / μs		
Maximum non repetitive di / dt	50 A/μs		
Contact type	Screw		
Contact	1 NO		
Load current	10 A	16 A	25 A
Thermal derating, refer to:	fig. 2.	fig. 3.	fig. 4.
Inrush current @ 10 ms	120 A	160 A	250 A
I ² t @ 10 ms	50 A ² s	128 A ² s	312 A ² s

Control circuit

Operating voltage range	4 ... 32 V DC
Maximum input current @ maximum operating voltage	25 mA
Pick-up voltage	4 V DC
Release voltage	1 V DC
Power consumption DC	0.8 W

Insulation

Rated test voltage input/output	4000 Vrms / 1 min
Rated test voltage input output/base	2500 Vrms / 1 min
Overvoltage category	III

General data

Ambient temperature storage (no ice)	-30 ... 100 °C
Ambient temperature operation	-30 ... 80 °C
Pick-up time	1 ms
Release time	10 ms
Power Factor	> 0.5
Protection degree	IP 00
Dimension	fig. 5.
Weight	35 g
Housing material	PBT

Product reference (o.r. = on request)

Description	Type	A		
		010	016	025
DC Control				
1 NO, LED, RC Protection	SP1MXN-TIX0240N...X/DC4-32V	✓	o.r.	✓
1 NO, LED, MOV (*1) and RC protection	SP1MXN-TIX0240V...X/DC4-32V	o.r.	o.r.	o.r.
1 NO, LED, TVS (*2) and RC protection	SP1MXN-TIX0240T...X/DC4-32V	✓	o.r.	✓

Complete load current to complete product reference

(*1) Maximum operating voltage allowed by MOV: 300 V AC

(*2) TVS protection voltage: 480 V

Heatsinks (to be used either with SP1M/pad or SP1/grease)

Heatsinks	Thermal resistance [°C/W]	Dimensions H x W x D (mm)	Mounting type
HS_003	1.9	81x50x82.5	DIN rail (with clip)
HS_010	2.8	80x32x50	Panel (with screws)
HS_012	2.1	80x50x50	Panel (with screws)
HS_015	0.6	106x80x96	Panel (with screws)
HS_020	1.6	106x50x96	Panel (with screws)

Accessories

Thermal conducting pad	SP1M/pad
Thermal conducting grease	SP1/grease
Transparent cover Can not be removed after assembly	SP1MXN/cover



fig. 1. Wiring diagram

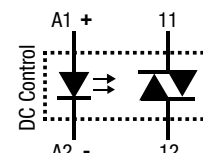


fig. 2. Thermal derating curve 10 A

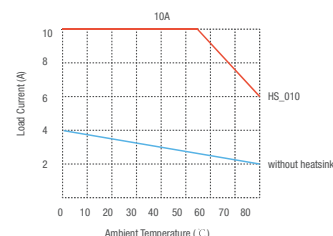


fig. 3. Thermal derating curve 16 A

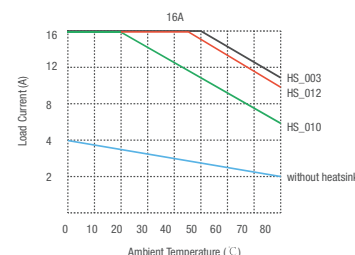


fig. 4. Thermal derating curve 25 A

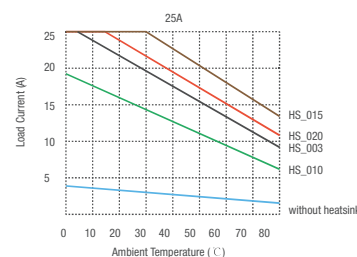
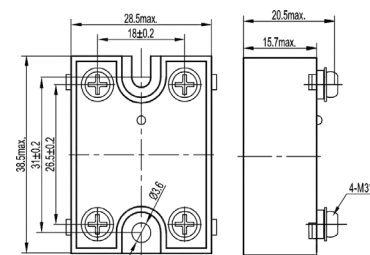


fig. 5. Dimension (mm)



Technical approvals, conformities

Standards EN 60950-1, EN 62314



SP1MXF-TZX0380



1 phase | normally open solid state AC up to 440V, 25A | synchr zero | Faston IP 00

Main circuit

Output type	⚡ Triac		
Type	Synchronized zero		
Rated voltage AC	380		
Output voltage range AC	24 ... 440 V		
Operating frequency	47 ... 63 Hz		
Recommended minimum contact load	100 mA		
Maximum leakage current @ rated voltage A	5 mA		
Maximum voltage drop @ rated current	≤ 1.5 V rms		
Repetitive peak voltage in off-state	800 Vpk		
Maximum off state dv / dt	200 V / μs		
Maximum non repetitive di / dt	50 A/μs		
Contact type	Faston		
Contact	1 NO		
Load current	10 A	16 A	25 A
Thermal derating, refer to:	fig. 2.	fig. 3.	fig. 4.
Inrush current @ 10 ms	120 A	160 A	250 A
I ² t @ 10 ms	50 A ² s	128 A ² s	312 A ² s

Control circuit

Operating voltage range	4 ... 32 V DC
Maximum input current @ maximum operating voltage	25 mA
Pick-up voltage	4 V DC
Release voltage	1 V DC
Power consumption DC	0.8 W

Insulation

Rated test voltage input/output	4000 Vrms / 1 min
Rated test voltage input output/base	2500 Vrms / 1 min
Overtoltage cathegory	III

General data

Ambient temperature storage (no ice)	-30 ... 100 °C
Ambient temperature operation	-30 ... 80 °C
Pick-up time	10 ms
Release time	10 ms
Power Factor	> 0.5
Protection degree	IP 00
Dimension	fig. 5.
Weight	35 g
Housing material	PBT

Product reference (o.r. = on request)

Description	Type	A		
		010	016	025
DC Control				
1 NO, LED, RC Protection	SP1MXF-TZX0380N...X/DC4-32V	✓	o.r.	✓
1 NO, LED, MOV (*1) and RC protection	SP1MXF-TZX0380V...X/DC4-32V	o.r.	o.r.	o.r.
1 NO, LED, TVS (*2) and RC protection	SP1MXF-TZX0380T...X/DC4-32V	✓	o.r.	✓

Complete load current to complete product reference

(*1) Maximum operating voltage allowed by MOV: 420 V AC

(*2) TVS protection voltage: 750 V

Heatsinks (to be used either with SP1M/pad or SP1/grease)

Heatsinks	Thermal resistance [°C/W]	Dimensions H x W x D (mm)	Mounting type
HS_003	1.9	81x50x82.5	DIN rail (with clip)
HS_010	2.8	80x32x50	Panel (with screws)
HS_012	2.1	80x50x50	Panel (with screws)
HS_015	0.6	106x80x96	Panel (with screws)
HS_020	1.6	106x50x96	Panel (with screws)

Accessories

Thermal conducting pad	SP1M/pad
Thermal conducting grease	SP1/grease



fig. 1. Wiring diagram

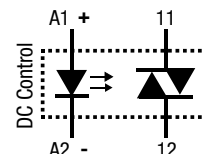


fig. 2. Thermal derating curve 10 A

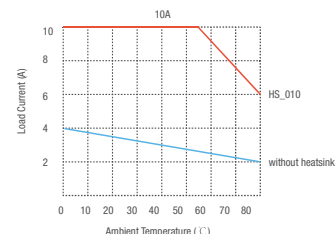


fig. 3. Thermal derating curve 16 A

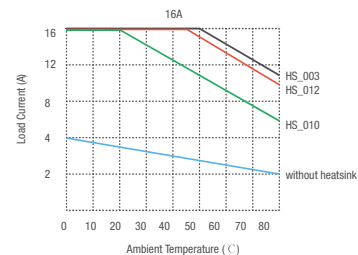


fig. 4. Thermal derating curve 25 A

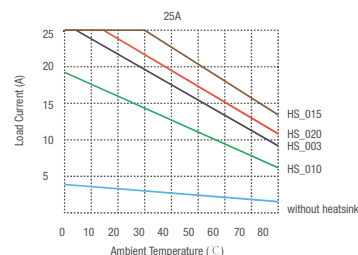
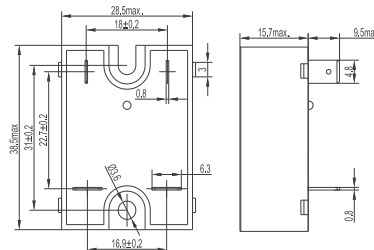


fig. 5. Dimension (mm)



Technical approvals, conformities

Standards EN 60950-1, EN 62314



SP1MXF-TIX0380

1 phase | normally open solid state AC up to 440V, 25A | instantaneous | Faston IP 00



Main circuit

Output type	⚡ Triac		
Type	Instantaneous		
Rated voltage AC	380		
Output voltage range AC	24 ... 440 V		
Operating frequency	47 ... 63 Hz		
Recommended minimum contact load	100 mA		
Maximum leakage current @ rated voltage A	5 mA		
Maximum voltage drop @ rated current	≤ 1.5 V rms		
Repetitive peak voltage in off-state	800 Vpk		
Maximum off state dv / dt	200 V / μs		
Maximum non repetitive di / dt	50 A/μs		
Contact type	Faston		
Contact	1 NO		
Load current	10 A	16 A	25 A
Thermal derating, refer to:	fig. 2.	fig. 3.	fig. 4.
Inrush current @ 10 ms	120 A	160 A	250 A
I ² t @ 10 ms	50 A ² s	128 A ² s	312 A ² s

Control circuit

Operating voltage range	4 ... 32 V DC
Maximum input current @ maximum operating voltage	25 mA
Pick-up voltage	4 V DC
Release voltage	1 V DC
Power consumption DC	0.8 W

Insulation

Rated test voltage input/output	4000 Vrms / 1 min
Rated test voltage input output/base	2500 Vrms / 1 min
Overvoltage category	III

General data

Ambient temperature storage (no ice)	-30 ... 100 °C
Ambient temperature operation	-30 ... 80 °C
Pick-up time	1 ms
Release time	10 ms
Power Factor	> 0.5
Protection degree	IP 00
Dimension	fig. 5.
Weight	35 g
Housing material	PBT

Product reference (o.r. = on request)

Description	Type	A		
		010	016	025
DC Control				
1 NO, LED, RC Protection	SP1MXF-TIX0380N...X/DC4-32V	✓	o.r.	✓
1 NO, LED, MOV (*1) and RC protection	SP1MXF-TIX0380V...X/DC4-32V	o.r.	o.r.	o.r.
1 NO, LED, TVS (*2) and RC protection	SP1MXF-TIX0380T...X/DC4-32V	✓	o.r.	✓

Complete load current to complete product reference

(*1) Maximum operating voltage allowed by MOV: 420 V AC

(*2) TVS protection voltage: 750 V

Heatsinks (to be used either with SP1M/pad or SP1/grease)

Heatsinks	Thermal resistance [°C/W]	Dimensions H x W x D (mm)	Mounting type
HS_003	1.9	81x50x82.5	DIN rail (with clip)
HS_010	2.8	80x32x50	Panel (with screws)
HS_012	2.1	80x50x50	Panel (with screws)
HS_015	0.6	106x80x96	Panel (with screws)
HS_020	1.6	106x50x96	Panel (with screws)

Accessories

Thermal conducting pad	SP1M/pad
Thermal conducting grease	SP1/grease



fig. 1. Wiring diagram

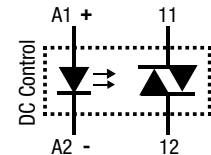


fig. 2. Thermal derating curve 10 A

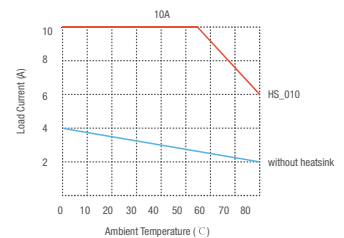


fig. 3. Thermal derating curve 16 A

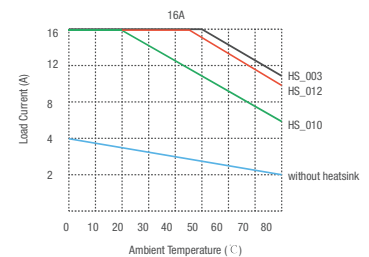


fig. 4. Thermal derating curve 25 A

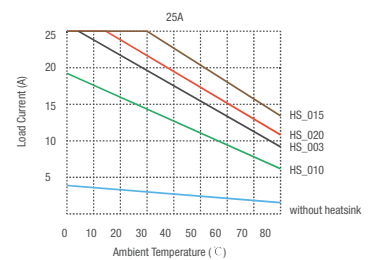
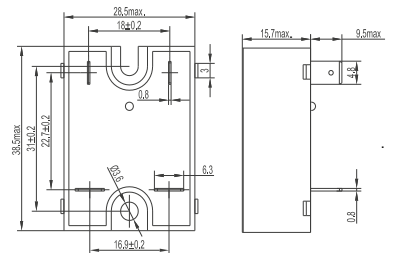


fig. 5. Dimension (mm)



Technical approvals, conformities

Standards EN 60950-1, EN 62314



SP1MXN-TZX0380

1 phase | normally open solid state AC up to 440V, 25A | synchr zero | Screw IP 00



Main circuit

Output type	⚡ Triac		
Type	Synchronized zero		
Rated voltage AC	380		
Output voltage range AC	24 ... 440 V		
Operating frequency	47 ... 63 Hz		
Recommended minimum contact load	100 mA		
Maximum leakage current @ rated voltage A	5 mA		
Maximum voltage drop @ rated current	≤ 1.5 V rms		
Repetitive peak voltage in off-state	800 Vpk		
Maximum off state dv / dt	200 V / μs		
Maximum non repetitive di / dt	50 A/μs		
Contact type	Screw		
Contact	1 NO		
Load current	10 A	16 A	25 A
Thermal derating, refer to:	fig. 2.	fig. 3.	fig. 4.
Inrush current @ 10 ms	120 A	160 A	250 A
I²t @ 10 ms	50 A²s	128 A²s	312 A²s

Control circuit

Operating voltage range	4 ... 32 V DC
Maximum input current @ maximum operating voltage	25 mA
Pick-up voltage	4 V DC
Release voltage	1 V DC
Power consumption DC	0.8 W

Insulation

Rated test voltage input/output	4000 Vrms / 1 min
Rated test voltage input output/base	2500 Vrms / 1 min
Overvoltage category	III

General data

Ambient temperature storage (no ice)	-30 ... 100 °C
Ambient temperature operation	-30 ... 80 °C
Pick-up time	10 ms
Release time	10 ms
Power Factor	> 0.5
Protection degree	IP 00
Dimension	fig. 5.
Weight	35 g
Housing material	PBT

Product reference (o.r. = on request)

Description	Type	A		
		010	016	025
DC Control				
1 NO, LED, RC Protection	SP1MXN-TZX0380N...X/DC4-32V	✓	o.r.	✓
1 NO, LED, MOV (*1) and RC protection	SP1MXN-TZX0380V...X/DC4-32V	o.r.	o.r.	o.r.
1 NO, LED, TVS (*2) and RC protection	SP1MXN-TZX0380T...X/DC4-32V	✓	o.r.	✓

Complete load current to complete product reference

(*1) Maximum operating voltage allowed by MOV: 420 V AC

(*2) TVS protection voltage: 750 V

Heatsinks (to be used either with SP1M/pad or SP1/grease)

Heatsinks	Thermal resistance [°C/W]	Dimensions H x W x D (mm)	Mounting type
HS_003	1.9	81x50x82.5	DIN rail (with clip)
HS_010	2.8	80x32x50	Panel (with screws)
HS_012	2.1	80x50x50	Panel (with screws)
HS_015	0.6	106x80x96	Panel (with screws)
HS_020	1.6	106x50x96	Panel (with screws)

Accessories

Thermal conducting pad	SP1M/pad
Thermal conducting grease	SP1/grease
Transparent cover Can not be removed after assembly	SP1MXN/cover



fig. 1. Wiring diagram

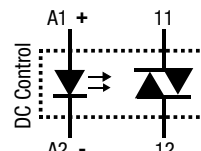


fig. 2. Thermal derating curve 10 A

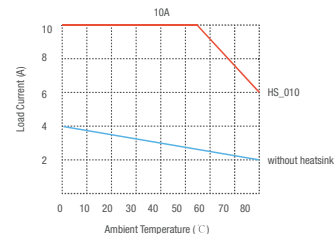


fig. 3. Thermal derating curve 16 A

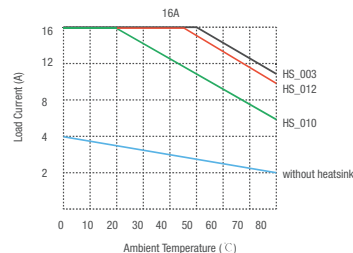


fig. 4. Thermal derating curve 25 A

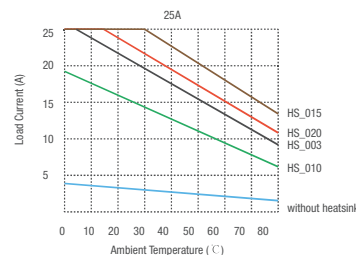
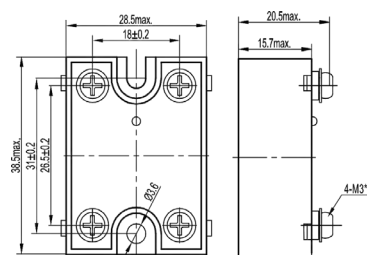


fig. 5. Dimension (mm)



Technical approvals, conformities

Standards EN 60950-1, EN 62314



SP1MXN-TIX0380

1 phase | normally open solid state AC up to 440V, 25A | instantaneous | Screw IP 00



Main circuit

Output type	⚡ Triac		
Type	Instantaneous		
Rated voltage AC	380		
Output voltage range AC	24 ... 440 V		
Operating frequency	47 ... 63 Hz		
Recommended minimum contact load	100 mA		
Maximum leakage current @ rated voltage A	5 mA		
Maximum voltage drop @ rated current	≤ 1.5 V rms		
Repetitive peak voltage in off-state	800 Vpk		
Maximum off state dv / dt	200 V / μs		
Maximum non repetitive di / dt	50 A/μs		
Contact type	Screw		
Contact	1 NO		
Load current	10 A	16 A	25 A
Thermal derating, refer to:	fig. 2.	fig. 3.	fig. 4.
Inrush current @ 10 ms	120 A	160 A	250 A
I ² t @ 10 ms	50 A ² s	128 A ² s	312 A ² s

Control circuit

Operating voltage range	4 ... 32 V DC
Maximum input current @ maximum operating voltage	25 mA
Pick-up voltage	4 V DC
Release voltage	1 V DC
Power consumption DC	0.8 W

Insulation

Rated test voltage input/output	4000 Vrms / 1 min
Rated test voltage input output/base	2500 Vrms / 1 min
Overvoltage category	III

General data

Ambient temperature storage (no ice)	-30 ... 100 °C
Ambient temperature operation	-30 ... 80 °C
Pick-up time	1 ms
Release time	10 ms
Power Factor	> 0.5
Protection degree	IP 00
Dimension	fig. 5.
Weight	35 g
Housing material	PBT

Product reference (o.r. = on request)

Description	Type	A		
		010	016	025
DC Control				
1 NO, LED, RC Protection	SP1MXN-TIX0380N...X/DC4-32V	✓	o.r.	✓
1 NO, LED, MOV (*1) and RC protection	SP1MXN-TIX0380V...X/DC4-32V	o.r.	o.r.	o.r.
1 NO, LED, TVS (*2) and RC protection	SP1MXN-TIX0380T...X/DC4-32V	✓	o.r.	✓

Complete load current to complete product reference

(*1) Maximum operating voltage allowed by MOV: 420 V AC

(*2) TVS protection voltage: 750 V

Heatsinks (to be used either with SP1M/pad or SP1/grease)

Heatsinks	Thermal resistance [°C/W]	Dimensions H x W x D (mm)	Mounting type
HS_003	1.9	81x50x82.5	DIN rail (with clip)
HS_010	2.8	80x32x50	Panel (with screws)
HS_012	2.1	80x50x50	Panel (with screws)
HS_015	0.6	106x80x96	Panel (with screws)
HS_020	1.6	106x50x96	Panel (with screws)

Accessories

Thermal conducting pad	SP1M/pad
Thermal conducting grease	SP1/grease
Transparent cover Can not be removed after assembly	SP1MXN/cover



fig. 1. Wiring diagram

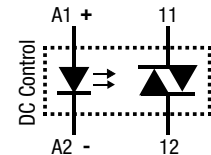


fig. 2. Thermal derating curve 10 A

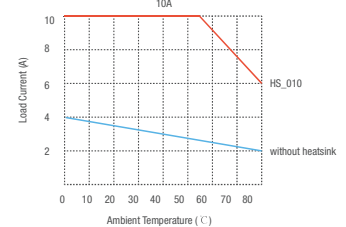


fig. 3. Thermal derating curve 16 A

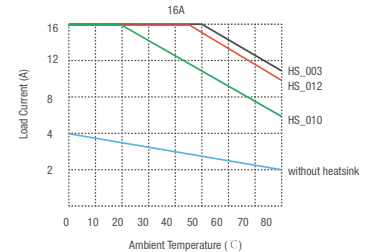


fig. 4. Thermal derating curve 25 A

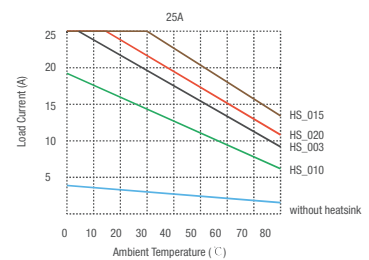
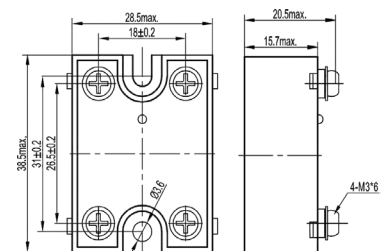


fig. 5. Dimension (mm)



Technical approvals, conformities

Standards EN 60950-1, EN 62314



SP1MXN-TIX0380

1 phase | normally open solid state AC up to 440V, 25A | instantaneous | Screw IP 00



Main circuit

Output type	⚡ Triac		
Type	Instantaneous		
Rated voltage AC	380		
Output voltage range AC	24 ... 440 V		
Operating frequency	47 ... 63 Hz		
Recommended minimum contact load	100 mA		
Maximum leakage current @ rated voltage A	5 mA		
Maximum voltage drop @ rated current	≤ 1.5 V rms		
Repetitive peak voltage in off-state	800 Vpk		
Maximum off state dv / dt	200 V / μs		
Maximum non repetitive di / dt	50 A/μs		
Contact type	Screw		
Contact	1 NO		
Load current	10 A	16 A	25 A
Thermal derating, refer to:	fig. 2.	fig. 3.	fig. 4.
Inrush current @ 10 ms	120 A	160 A	250 A
I²t @ 10 ms	50 A²s	128 A²s	312 A²s

Control circuit

Operating voltage range	4 ... 32 V DC
Maximum input current @ maximum operating voltage	25 mA
Pick-up voltage	4 V DC
Release voltage	1 V DC
Power consumption DC	0.8 W

Insulation

Rated test voltage input/output	4000 Vrms / 1 min
Rated test voltage input output/base	2500 Vrms / 1 min
Overtoltage category	III

General data

Ambient temperature storage (no ice)	-30 ... 100 °C
Ambient temperature operation	-30 ... 80 °C
Pick-up time	1 ms
Release time	10 ms
Power Factor	> 0.5
Protection degree	IP 00
Dimension	fig. 5.
Weight	35 g
Housing material	PBT

Product reference (o.r. = on request)

Description	Type	A		
		010	016	025
DC Control				
1 NO, LED, RC Protection	SP1MXN-TIX0380N...X/DC4-32V	✓	o.r.	✓
1 NO, LED, MOV (*1) and RC protection	SP1MXN-TIX0380V...X/DC4-32V	o.r.	o.r.	o.r.
1 NO, LED, TVS (*2) and RC protection	SP1MXN-TIX0380T...X/DC4-32V	✓	o.r.	✓

Complete load current to complete product reference

(*1) Maximum operating voltage allowed by MOV: 420 V AC

(*2) TVS protection voltage: 750 V

Heatsinks (to be used either with SP1M/pad or SP1/grease)

Heatsinks	Thermal resistance [°C/W]	Dimensions H x W x D (mm)	Mounting type
HS_003	1.9	81x50x82.5	DIN rail (with clip)
HS_010	2.8	80x32x50	Panel (with screws)
HS_012	2.1	80x50x50	Panel (with screws)
HS_015	0.6	106x80x96	Panel (with screws)
HS_020	1.6	106x50x96	Panel (with screws)

Accessories

Thermal conducting pad	SP1M/pad
Thermal conducting grease	SP1/grease
Transparent cover Can not be removed after assembly	SP1MXN/cover



fig. 1. Wiring diagram

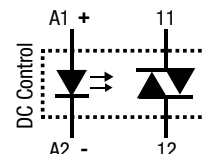


fig. 2. Thermal derating curve 10 A

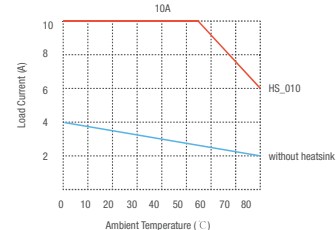


fig. 3. Thermal derating curve 16 A

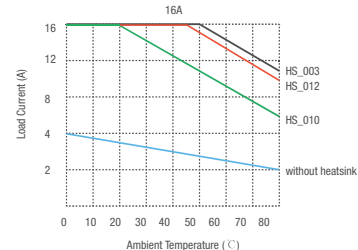


fig. 4. Thermal derating curve 25 A

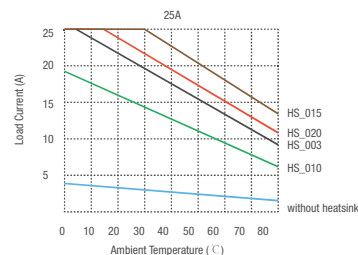
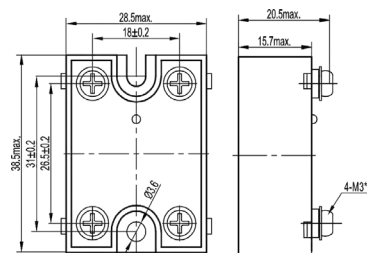


fig. 5. Dimension (mm)



Technical approvals, conformities

Standards EN 60950-1, EN 62314



3.3 SSR / SP1P

	Type	Page
1 phase normally open solid state AC up to 280V, 20A till 125A instantaneous or synchr zero	SP1PXx-Txx0240	40-49
1 phase normally open solid state AC up to 530V, 20A till 125A instantaneous or synchr zero	SP1PXN-Txx0480	50-55
1 phase normally open solid state AC up to 660V, 20A till 125A instantaneous or synchr zero	SP1PXN-Txx0600	56-61
1 phase normally open solid state AC up to 280V, 20A till 80A instantaneous or synchr zero	SP1PXS-Txx0240	62-67
1 phase normally open solid state AC up to 530V, 20A till 80A instantaneous or synchr zero	SP1PXS-Txx0480	68-73
1 phase normally open solid state AC up to 660V, 20A till 80A instantaneous or synchr zero	SP1PXS-Txx0600	74-79

SP1PXF-TIX0240

1 phase | normally open solid state AC up to 280V, 20A | instantaneous | Faston IP 00



Main circuit

Output type	⚡ Triac		
Type	Instantaneous		
Rated voltage AC	240		
Output voltage range AC	48 ... 280 V		
Operating frequency	47 ... 63 Hz		
Recommended minimum contact load	100 mA		
Maximum leakage current @ rated voltage A	10 mA		
Maximum voltage drop @ rated current	≤ 1.7 V rms		
Repetitive peak voltage in off-state	600 Vpk		
Maximum off state dv / dt	200 V / μs		
Maximum non repetitive di / dt	50 A/μs		
Contact type	Faston		
Contact	1 NO		
Load current	10 A	15 A	20 A
Thermal derating, refer to:	fig. 2.	fig. 3.	fig. 4.
Inrush current @ 10 ms	120 A	160 A	200 A
I²t @ 10 ms	72 A²s	128 A²s	200 A²s

Control circuit

Operating voltage range	4 ... 32 V DC	90 ... 280 V AC
Maximum input current @ maximum operating voltage	25 mA	25 mA
Pick-up voltage	4 V DC	90 V AC
Release voltage	1 V DC	10 V AC
Power consumption DC / AC	0.8 W	7 VA

Insulation

Rated test voltage input/output	4000 Vrms / 1 min
Rated test voltage input output/base	2500 Vrms / 1 min
Overvoltage category	III

General data

Ambient temperature storage (no ice)	-30 ... 100 °C
Ambient temperature operation	-30 ... 80 °C
Pick up time DC control / AC control	1 ms / 40 ms
Release time DC control / AC control	1/2 cycle + 1 ms / 40 ms
Power Factor	> 0.5
Protection degree	IP 00
Dimension	fig. 5.
Weight	96 g
Housing material	PBT

Product reference (o.r. = on request)

Description	Type	A		
		010	015	020
DC Control				
1 NO, Led, RC Protection	SP1PXF-TIX0240N...X/DC4-32V	o.r.	o.r.	o.r.
1 NO, Led, MOV and RC protection	SP1PXF-TIX0240V...X/DC4-32V	o.r.	o.r.	o.r.
1 NO, Led, TVS and RC protection	SP1PXF-TIX0240T...X/DC4-32V	o.r.	o.r.	o.r.
AC Control				
1 NO, Led, RC Protection	SP1PXF-TIX0240N...X/AC90-280V	o.r.	o.r.	o.r.
1 NO, Led, MOV and RC protection	SP1PXF-TIX0240V...X/AC90-280V	o.r.	o.r.	o.r.
1 NO, Led, TVS and RC protection	SP1PXF-TIX0240T...X/AC90-280V	o.r.	o.r.	o.r.

Complete load current to complete product reference

(*1) Maximum operating voltage allowed by MOV: 300 V AC

(*2) TVS protection voltage: 480 V

Heatsinks (to be used either with SP1P/pad or SP1/grease). Further heatsink options are shown in the following chapter.

Heatsinks	Thermal resistance [°C/W]	Dimensions H x W x D (mm)	Mounting type
HS_003	1.9	81x50x82.5	DIN rail (with clip)
HS_012	2.1	81x50x50	Panel (with screws)
HS_005	1.6	122x55x59	DIN rail (with clip)

Accessories

Thermal conducting pad

SP1P/pad

Thermal conducting grease

SP1/grease



fig. 1. Wiring diagram

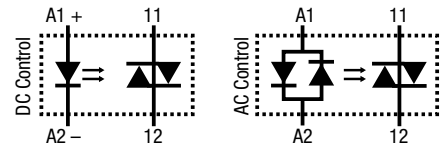


fig. 2. Thermal derating curve 10 A

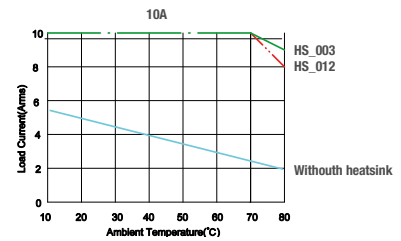


fig. 3. Thermal derating curve 15 A

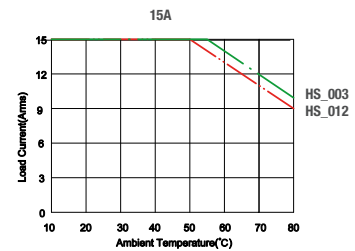


fig. 4. Thermal derating curve 20 A

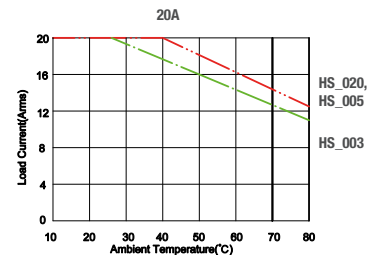
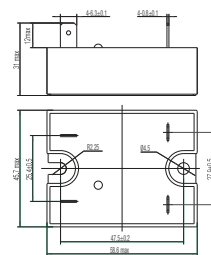


fig. 5. Dimension (mm)



Technical approvals, conformities

Standards EN 60950-1, EN 62314

Approvals

SP1PXF-TZX0240

1 phase | normally open solid state AC up to 280V, 40A | synchr zero | Faston IP 00



3 SSR panel or DIN rail mounted

3

Main circuit

Output type	SCR
Type	Synchronized zero
Rated voltage AC	240
Output voltage range AC	48 ... 280 V
Operating frequency	47 ... 63 Hz
Recommended minimum contact load	100 mA
Maximum leakage current @ rated voltage A	10 mA
Maximum voltage drop @ rated current	≤ 1.7 V rms
Repetitive peak voltage in off-state	600 Vpk
Maximum off state dv / dt	500 V / μs
Maximum non repetitive di / dt	50 A/μs
Contact type	Faston
Contact	1 NO
Load current	25 A 40 A
Thermal derating, refer to:	fig. 2. fig. 3.
Inrush current @ 10 ms	250 A 500 A
I ² t @ 10 ms	312 A ² s 1250 A ² s

Control circuit

Operating voltage range	4 ... 32 V DC	90 ... 280 V AC
Maximum input current @ maximum operating voltage	25 mA	25 mA
Pick-up voltage	4 V DC	90 V AC
Release voltage	1 V DC	10 V AC
Power consumption DC / AC	0.8 W	7 VA

Insulation

Rated test voltage input/output	4000 Vrms / 1 min
Rated test voltage input output/base	2500 Vrms / 1 min
Oversvoltage cathegory	III

General data

Ambient temperature storage (no ice)	-30 ... 100 °C
Ambient temperature operation	-30 ... 80 °C
Pick up time DC control / AC control	1/2 cycle + 1 ms / 40 ms
Release time DC control / AC control	1/2 cycle + 1 ms / 40 ms
Power Factor	> 0.5
Protection degree	IP 00
Dimension	fig. 5.
Weight	96 g
Housing material	PBT

Product reference (o.r. = on request)

Description	Type	A	
		025	040
DC Control			
1 NO, Led, RC Protection	SP1PXF-TZX0240N...X/DC4-32V	o.r.	o.r.
1 NO, Led, MOV and RC protection	SP1PXF-TZX0240V...X/DC4-32V	o.r.	o.r.
1 NO, Led, TVS and RC protection	SP1PXF-TZX0240T...X/DC4-32V	o.r.	o.r.
AC Control			
1 NO, Led, RC Protection	SP1PXF-TZX0240N...X/AC90-280V	o.r.	o.r.
1 NO, Led, MOV and RC protection	SP1PXF-TZX0240V...X/AC90-280V	o.r.	o.r.
1 NO, Led, TVS and RC protection	SP1PXF-TZX0240T...X/AC90-280V	o.r.	o.r.

Complete load current to complete product reference

(*1) Maximum operating voltage allowed by MOV: 300 V AC

(*2) TVS protection voltage: 480 V

Heatsinks (to be used either with SP1P/pad or SP1/grease). Further heatsink options are shown in the following chapter.

Heatsinks	Thermal resistance [°C/W]	Dimensions H x W x D (mm)	Mounting type
HS_005	1.6	122x55x59	DIN rail (with clip)
HS_020	1.6	106x50x96	Panel (with screws)
HS_007	0.8	122.5x81x100.5	DIN rail (with clip)

Accessories

Thermal conducting pad	SP1P/pad
Thermal conducting grease	SP1/grease



fig. 1. Wiring diagram

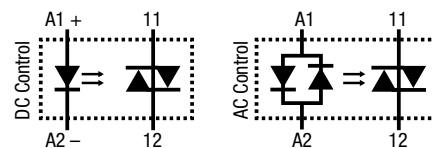


fig. 2. Thermal derating curve 25 A

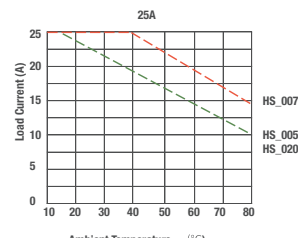


fig. 3. Thermal derating curve 40 A

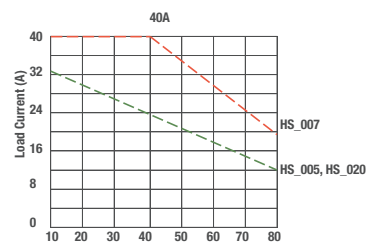
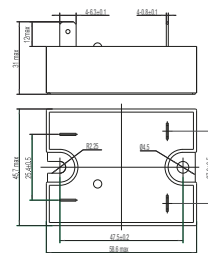


fig. 4. Dimension (mm)



Technical approvals, conformities

Standards EN 60950-1, EN 62314

Approvals

SP1PXF-TIX0240

1 phase | normally open solid state AC up to 280V, 40A | instantaneous | Faston IP 00



Main circuit

Output type	SCR	
Type	Instantaneous	
Rated voltage AC	240	
Output voltage range AC	48 ... 280 V	
Operating frequency	47 ... 63 Hz	
Recommended minimum contact load	100 mA	
Maximum leakage current @ rated voltage A	10 mA	
Maximum voltage drop @ rated current	≤ 1.7 V rms	
Repetitive peak voltage in off-state	600 Vpk	
Maximum off state dv / dt	500 V / μs	
Maximum non repetitive di / dt	50 A/μs	
Contact type	Faston	
Contact	1 NO	
Load current	25 A	40 A
Thermal derating, refer to:	fig. 2.	fig. 3.
Inrush current @ 10 ms	250 A	500 A
I²t @ 10 ms	312 A²s	1250 A²s

Control circuit

Operating voltage range	4 ... 32 V DC	90 ... 280 V AC
Maximum input current @ maximum operating voltage	25 mA	25 mA
Pick-up voltage	4 V DC	90 V AC
Release voltage	1 V DC	10 V AC
Power consumption DC / AC	0.8 W	7 VA

Insulation

Rated test voltage input/output	4000 Vrms / 1 min
Rated test voltage input output/base	2500 Vrms / 1 min
Overvoltage category	III

General data

Ambient temperature storage (no ice)	-30 ... 100 °C
Ambient temperature operation	-30 ... 80 °C
Pick up time DC control / AC control	1 ms / 40 ms
Release time DC control / AC control	1/2 cycle + 1 ms / 40 ms
Power Factor	> 0.5
Protection degree	IP 00
Dimension	fig. 5.
Weight	96 g
Housing material	PBT

Product reference (o.r. = on request)

Description	Type	A	
		025	040
DC Control			
1 NO, Led, RC Protection	SP1PXF-TIX0240N...X/DC4-32V	o.r.	o.r.
1 NO, Led, MOV and RC protection	SP1PXF-TIX0240V...X/DC4-32V	o.r.	o.r.
1 NO, Led, TVS and RC protection	SP1PXF-TIX0240T...X/DC4-32V	o.r.	o.r.
AC Control			
1 NO, Led, RC Protection	SP1PXF-TIX0240N...X/AC90-280V	o.r.	o.r.
1 NO, Led, MOV and RC protection	SP1PXF-TIX0240V...X/AC90-280V	o.r.	o.r.
1 NO, Led, TVS and RC protection	SP1PXF-TIX0240T...X/AC90-280V	o.r.	o.r.

Complete load current to complete product reference
 (*1) Maximum operating voltage allowed by MOV: 300 V AC
 (*2) TVS protection voltage: 480 V

Heatsinks (to be used either with SP1P/pad or SP1/grease). Further heatsink options are shown in the following chapter.

Heatsinks	Thermal resistance [°C/W]	Dimensions H x W x D (mm)	Mounting type
HS_005	1.6	122x55x59	DIN rail (with clip)
HS_020	1.6	106x50x96	Panel (with screws)
HS_007	0.8	122.5x81x100.5	DIN rail (with clip)

Accessories

Thermal conducting pad	SP1P/pad
Thermal conducting grease	SP1/grease



fig. 1. Wiring diagram

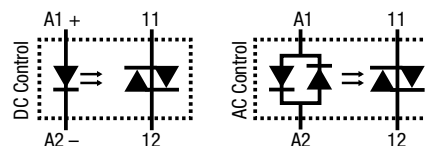


fig. 2. Thermal derating curve 25 A

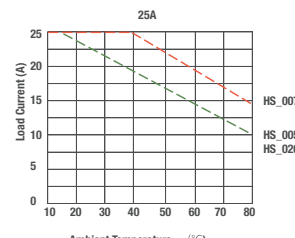


fig. 3. Thermal derating curve 40 A

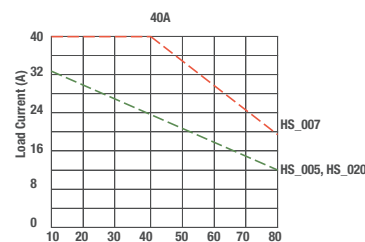
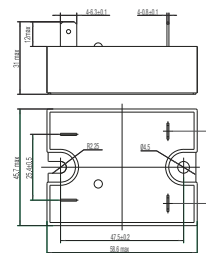


fig. 4. Dimension (mm)



Technical approvals, conformities

Standards EN 60950-1, EN 62314

Approvals

SP1PXN-TZX0240

1 phase | normally open solid state AC up to 280V, 20A | synchr zero | screw IP 00



Main circuit

Output type	⚡ Triac		
Type	Synchronized zero		
Rated voltage AC	240		
Output voltage range AC	48 ... 280 V		
Operating frequency	47 ... 63 Hz		
Recommended minimum contact load	100 mA		
Maximum leakage current @ rated voltage A	10 mA		
Maximum voltage drop @ rated current	≤ 1.7 V rms		
Repetitive peak voltage in off-state	600 Vpk		
Maximum off state dv / dt	200 V / μs		
Maximum non repetitive di / dt	50 A/μs		
Contact type	Screw		
Contact	1 NO		
Load current	10 A	15 A	20 A
Thermal derating, refer to:	fig. 2.	fig. 3.	fig. 4.
Inrush current @ 10 ms	120 A	160 A	200 A
I ² t @ 10 ms	72 A ² s	128 A ² s	200 A ² s

Control circuit

Operating voltage range	4 ... 32 V DC	90 ... 280 V AC
Maximum input current @ maximum operating voltage	25 mA	25 mA
Pick-up voltage	4 V DC	90 V AC
Release voltage	1 V DC	10 V AC
Power consumption DC / AC	0.8 W	7 VA

Insulation

Rated test voltage input/output	4000 Vrms / 1 min
Rated test voltage input output/base	2500 Vrms / 1 min
Overvoltage category	III

General data

Ambient temperature storage (no ice)	-30 ... 100 °C
Ambient temperature operation	-30 ... 80 °C
Pick up time DC control / AC control	1/2 cycle + 1 ms / 40 ms
Release time DC control / AC control	1/2 cycle + 1 ms / 40 ms
Power Factor	> 0.5
Protection degree	IP 00
Dimension	fig. 5.
Weight	100 g
Housing material	PBT

Product reference (o.r. = on request)

Description	Type	A		
		010	015	020
DC Control				
1 NO, Led, RC Protection	SP1PXN-TZX0240N...X/DC4-32V	o.r.	o.r.	o.r.
1 NO, Led, MOV and RC protection	SP1PXN-TZX0240V...X/DC4-32V	o.r.	o.r.	o.r.
1 NO, Led, TVS and RC protection	SP1PXN-TZX0240T...X/DC4-32V	o.r.	o.r.	o.r.
AC Control				
1 NO, Led, RC Protection	SP1PXN-TZX0240N...X/AC90-280V	o.r.	o.r.	o.r.
1 NO, Led, MOV and RC protection	SP1PXN-TZX0240V...X/AC90-280V	o.r.	o.r.	o.r.
1 NO, Led, TVS and RC protection	SP1PXN-TZX0240T...X/AC90-280V	o.r.	o.r.	o.r.

Complete load current to complete product reference

(*1) Maximum operating voltage allowed by MOV: 300 V AC

(*2) TVS protection voltage: 480 V

Heatsinks (to be used either with SP1P/pad or SP1/grease). Further heatsink options are shown in the following chapter.

Heatsinks	Thermal resistance [°C/W]	Dimensions H x W x D (mm)	Mounting type
HS_003	1.9	106x96x110	DIN rail (with clip)
HS_012	2.1	106x96x50	Panel (with screws)
HS_005	1.6	122x55x59	DIN rail (with clip)

Accessories

Thermal conducting pad	SP1P/pad
Thermal conducting grease	SP1/grease
Transparent cover can be removed after assembly	SP1PXN/cover



fig. 1. Wiring diagram

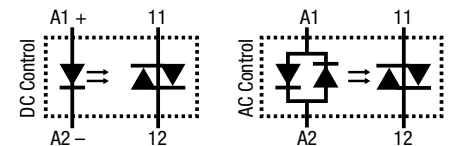


fig. 2. Thermal derating curve 10 A

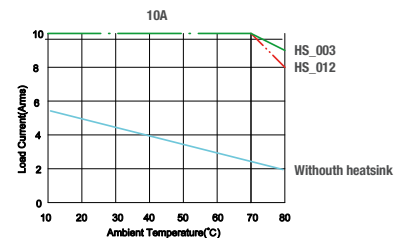


fig. 3. Thermal derating curve 15 A

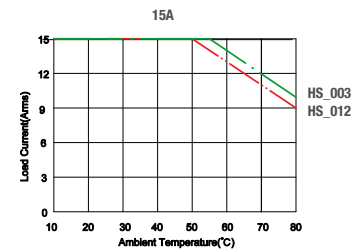


fig. 4. Thermal derating curve 20 A

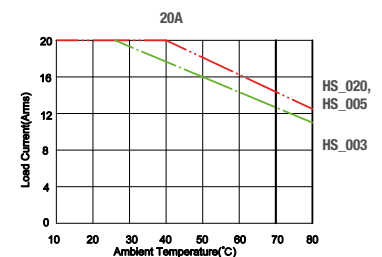
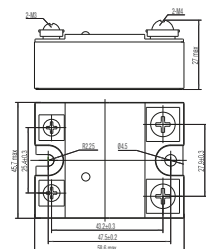


fig. 5. Dimension (mm)



Technical approvals, conformities

Standards EN 60950-1, EN 62314



SP1PXN-TIX0240

1 phase | normally open solid state AC up to 280V, 20A | instantaneous | screw IP 00

Main circuit

Output type	⚡ Triac		
Type	Instantaneous		
Rated voltage AC	240		
Output voltage range AC	48 ... 280 V		
Operating frequency	47 ... 63 Hz		
Recommended minimum contact load	100 mA		
Maximum leakage current @ rated voltage A	10 mA		
Maximum voltage drop @ rated current	≤ 1.7 V rms		
Repetitive peak voltage in off-state	600 Vpk		
Maximum off state dv / dt	200 V / μs		
Maximum non repetitive di / dt	50 A/μs		
Contact type	Screw		
Contact	1 NO		
Load current	10 A	15 A	20 A
Thermal derating, refer to:	fig. 2.	fig. 3.	fig. 4.
Inrush current @ 10 ms	120 A	160 A	200 A
I²t @ 10 ms	72 A²s	128 A²s	200 A²s

Control circuit

Operating voltage range	4 ... 32 V DC	90 ... 280 V AC
Maximum input current @ maximum operating voltage	25 mA	25 mA
Pick-up voltage	4 V DC	90 V AC
Release voltage	1 V DC	10 V AC
Power consumption DC / AC	0.8 W	7 VA

Insulation

Rated test voltage input/output	4000 Vrms / 1 min
Rated test voltage input output/base	2500 Vrms / 1 min
Overvoltage category	III

General data

Ambient temperature storage (no ice)	-30 ... 100 °C
Ambient temperature operation	-30 ... 80 °C
Pick up time DC control / AC control	1 ms / 40 ms
Release time DC control / AC control	1/2 cycle + 1 ms / 40 ms
Power Factor	> 0.5
Protection degree	IP 00
Dimension	fig. 5.
Weight	100 g
Housing material	PBT

Product reference (o.r. = on request)

Description	Type	A		
		010	015	020
DC Control				
1 NO, Led, RC Protection	SP1PXN-TIX0240N...X/DC4-32V	o.r.	o.r.	o.r.
1 NO, Led, MOV and RC protection	SP1PXN-TIX0240V...X/DC4-32V	o.r.	o.r.	o.r.
1 NO, Led, TVS and RC protection	SP1PXN-TIX0240T...X/DC4-32V	o.r.	o.r.	o.r.
AC Control				
1 NO, Led, RC Protection	SP1PXN-TIX0240N...X/AC90-280V	o.r.	o.r.	o.r.
1 NO, Led, MOV and RC protection	SP1PXN-TIX0240V...X/AC90-280V	o.r.	o.r.	o.r.
1 NO, Led, TVS and RC protection	SP1PXN-TIX0240T...X/AC90-280V	o.r.	o.r.	o.r.

Complete load current to complete product reference
 (*1) Maximum operating voltage allowed by MOV: 300 V AC
 (*2) TVS protection voltage: 480 V

Heatsinks (to be used either with SP1P/pad or SP1/grease). Further heatsink options are shown in the following chapter.

Heatsinks	Thermal resistance [°C/W]	Dimensions H x W x D (mm)	Mounting type
HS_003	1.9	106x96x110	DIN rail (with clip)
HS_012	2.1	106x96x50	Panel (with screws)
HS_005	1.6	122x55x59	DIN rail (with clip)

Accessories

Thermal conducting pad	SP1P/pad
Thermal conducting grease	SP1/grease
Transparent cover can be removed after assembly	SP1PXN/cover



fig. 1. Wiring diagram

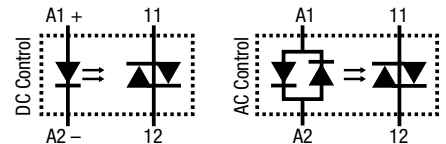


fig. 2. Thermal derating curve 10 A

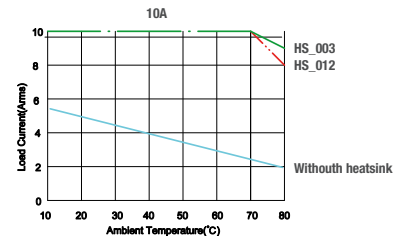


fig. 3. Thermal derating curve 15 A

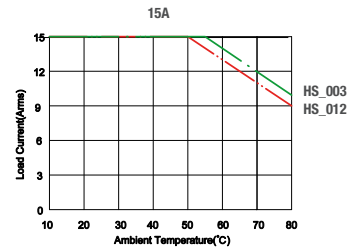


fig. 4. Thermal derating curve 20 A

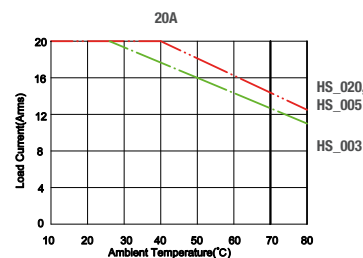
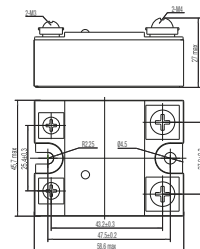


fig. 5. Dimension (mm)



Technical approvals, conformities

Standards EN 60950-1, EN 62314



SP1PXN-TZX0240

1 phase | normally open solid state AC up to 280V, 60A | synchr zero | screw IP 00



Main circuit

Output type	⚡ SCR		
Type	Synchronized zero		
Rated voltage AC	240		
Output voltage range AC	48 ... 280 V		
Operating frequency	47 ... 63 Hz		
Recommended minimum contact load	100 mA		
Maximum leakage current @ rated voltage A	10 mA		
Maximum voltage drop @ rated current	≤ 1.7 V rms		
Repetitive peak voltage in off-state	600 Vpk		
Maximum off state dv / dt	500 V / μs		
Maximum non repetitive di / dt	50 A/μs		
Contact type	Screw		
Contact	1 NO		
Load current	25 A	40 A	60 A
Thermal derating, refer to:	fig. 2.	fig. 3.	fig. 4.
Inrush current @ 10 ms	250 A	500 A	700 A
I ² t @ 10 ms	312 A ² s	1250 A ² s	2450 A ² s

Control circuit

Operating voltage range	4 ... 32 V DC	90 ... 280 V AC
Maximum input current @ maximum operating voltage	25 mA	25 mA
Pick-up voltage	4 V DC	90 V AC
Release voltage	1 V DC	10 V AC
Power consumption DC / AC	0.8 W	7 VA

Insulation

Rated test voltage input/output	4000 Vrms / 1 min
Rated test voltage input output/base	2500 Vrms / 1 min
Overvoltage category	III

General data

Ambient temperature storage (no ice)	-30 ... 100 °C
Ambient temperature operation	-30 ... 80 °C
Pick up time DC control / AC control	1/2 cycle + 1 ms / 40 ms
Release time DC control / AC control	1/2 cycle + 1 ms / 40 ms
Power Factor	> 0.5
Protection degree	IP 00
Dimension	fig. 5.
Weight	100 g
Housing material	PBT

Product reference (o.r. = on request)

Description	Type	A		
		025	040	060
DC Control				
1 NO, Led, RC Protection	SP1PXN-TZX0240N...X/DC4-32V	o.r.	o.r.	o.r.
1 NO, Led, MOV and RC protection	SP1PXN-TZX0240V...X/DC4-32V	o.r.	o.r.	o.r.
1 NO, Led, TVS and RC protection	SP1PXN-TZX0240T...X/DC4-32V	o.r.	o.r.	o.r.
AC Control				
1 NO, Led, RC Protection	SP1PXN-TZX0240N...X/AC90-280V	o.r.	o.r.	o.r.
1 NO, Led, MOV and RC protection	SP1PXN-TZX0240V...X/AC90-280V	o.r.	o.r.	o.r.
1 NO, Led, TVS and RC protection	SP1PXN-TZX0240T...X/AC90-280V	o.r.	o.r.	o.r.

Complete load current to complete product reference

(*1) Maximum operating voltage allowed by MOV: 300 V AC

(*2) TVS protection voltage: 480 V

Heatsinks (to be used either with SP1P/pad or SP1/grease). Further heatsink options are shown in the following chapter.

Heatsinks	Thermal resistance [°C/W]	Dimensions H x W x D (mm)	Mounting type
HS_005	1.6	122x55x59	DIN rail (with clip)
HS_020	1.6	106x50x96	Panel (with screws)
HS_007	0.8	122.5x81x100.5	DIN rail (with clip)

Accessories

Thermal conducting pad	SP1P/pad
Thermal conducting grease	SP1/grease
Transparent cover can be removed after assembly	SP1PXN/cover



fig. 1. Wiring diagram

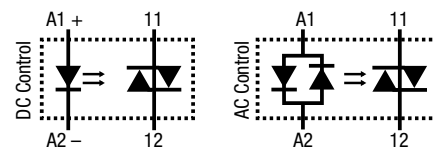


fig. 2. Thermal derating curve 25 A

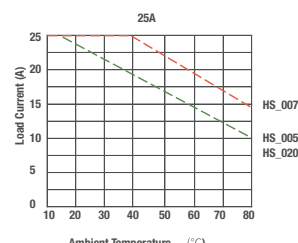


fig. 3. Thermal derating curve 40 A

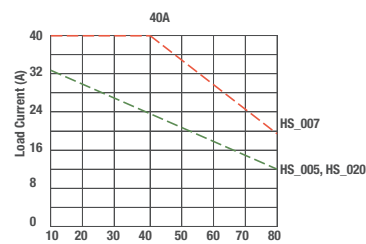


fig. 4. Thermal derating curve 60 A

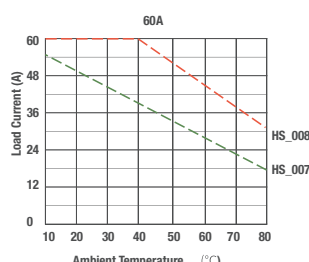
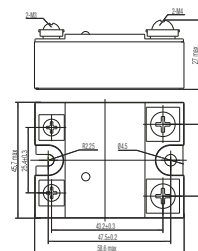


fig. 5. Dimension (mm)



Technical approvals, conformities

Standards EN 60950-1, EN 62314



SP1PXN-TIX0240



1 phase | normally open solid state AC up to 280V, 60A | instantaneous | screw IP 00

Main circuit

Output type	⚡ SCR		
Type	Instantaneous		
Rated voltage AC	240		
Output voltage range AC	48 ... 280 V		
Operating frequency	47 ... 63 Hz		
Recommended minimum contact load	100 mA		
Maximum leakage current @ rated voltage A	10 mA		
Maximum voltage drop @ rated current	≤ 1.7 V rms		
Repetitive peak voltage in off-state	600 Vpk		
Maximum off state dv / dt	500 V / μs		
Maximum non repetitive di / dt	50 A/μs		
Contact type	Screw		
Contact	1 NO		
Load current	25 A	40 A	60 A
Thermal derating, refer to:	fig. 2.	fig. 3.	fig. 4.
Inrush current @ 10 ms	250 A	500 A	700 A
I²t @ 10 ms	312 A²s	1250 A²s	2450 A²s

Control circuit

Operating voltage range	4 ... 32 V DC	90 ... 280 V AC
Maximum input current @ maximum operating voltage	25 mA	25 mA
Pick-up voltage	4 V DC	90 V AC
Release voltage	1 V DC	10 V AC
Power consumption DC / AC	0.8 W	7 VA

Insulation

Rated test voltage input/output	4000 Vrms / 1 min
Rated test voltage input output/base	2500 Vrms / 1 min
Overvoltage category	III

General data

Ambient temperature storage (no ice)	-30 ... 100 °C
Ambient temperature operation	-30 ... 80 °C
Pick up time DC control / AC control	1 ms / 40 ms
Release time DC control / AC control	1/2 cycle + 1 ms / 40 ms
Power Factor	> 0.5
Protection degree	IP 00
Dimension	fig. 5.
Weight	100 g
Housing material	PBT

Product reference (o.r. = on request)

Description	Type	A		
		025	040	060
DC Control				
1 NO, Led, RC Protection	SP1PXN-TIX0240N...X/DC4-32V	o.r.	o.r.	o.r.
1 NO, Led, MOV and RC protection	SP1PXN-TIX0240V...X/DC4-32V	o.r.	o.r.	o.r.
1 NO, Led, TVS and RC protection	SP1PXN-TIX0240T...X/DC4-32V	o.r.	o.r.	o.r.
AC Control				
1 NO, Led, RC Protection	SP1PXN-TIX0240N...X/AC90-280V	o.r.	o.r.	o.r.
1 NO, Led, MOV and RC protection	SP1PXN-TIX0240V...X/AC90-280V	o.r.	o.r.	o.r.
1 NO, Led, TVS and RC protection	SP1PXN-TIX0240T...X/AC90-280V	o.r.	o.r.	o.r.

Complete load current to complete product reference

(*1) Maximum operating voltage allowed by MOV: 300 V AC

(*2) TVS protection voltage: 480 V

Heatsinks (to be used either with SP1P/pad or SP1/grease). Further heatsink options are shown in the following chapter.

Heatsinks	Thermal resistance [°C/W]	Dimensions H x W x D (mm)	Mounting type
HS_005	1.6	122x55x59	DIN rail (with clip)
HS_020	1.6	106x50x96	Panel (with screws)
HS_007	0.8	122.5x81x100.5	DIN rail (with clip)

Accessories

Thermal conducting pad	SP1P/pad
Thermal conducting grease	SP1/grease
Transparent cover can be removed after assembly	SP1PXN/cover



fig. 1. Wiring diagram

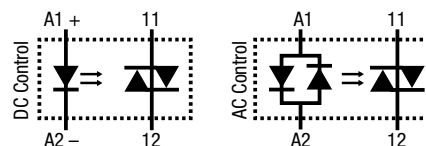


fig. 2. Thermal derating curve 25 A

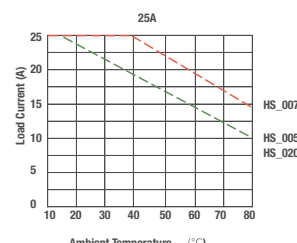


fig. 3. Thermal derating curve 40 A

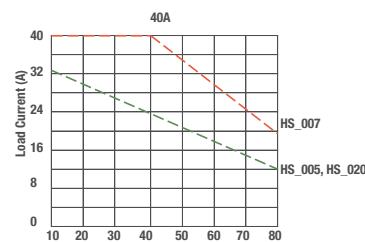


fig. 4. Thermal derating curve 60 A

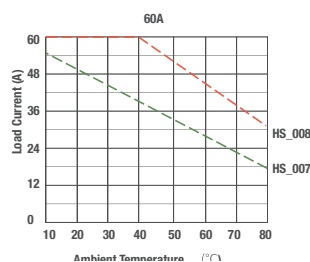
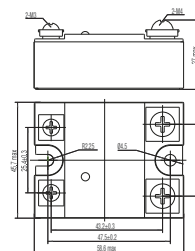


fig. 5. Dimension (mm)



Technical approvals, conformities

Standards EN 60950-1, EN 62314



SP1PXN-TZX0240

1 phase | normally open solid state AC up to 280V, 125A | synchr zero | screw IP 00



Main circuit

Output type	⚡ SCR		
Type	Synchronized zero		
Rated voltage AC	240		
Output voltage range AC	48 ... 280 V		
Operating frequency	47 ... 63 Hz		
Recommended minimum contact load	100 mA		
Maximum leakage current @ rated voltage A	10 mA		
Maximum voltage drop @ rated current	≤ 1.7 V rms		
Repetitive peak voltage in off-state	600 Vpk		
Maximum off state dv / dt	500 V / μs		
Maximum non repetitive di / dt	50 A/μs		
Contact type	Screw		
Contact	1 NO		
Load current	80 A	100 A	125 A
Thermal derating, refer to:	fig. 2.	fig. 3.	fig. 4.
Inrush current @ 10 ms	1000 A	1250 A	1500 A
I ² t @ 10 ms	5000 A ² s	7812 A ² s	11250 A ² s

Control circuit

Operating voltage range	4 ... 32 V DC	90 ... 280 V AC
Maximum input current @ maximum operating voltage	25 mA	25 mA
Pick-up voltage	4 V DC	90 V AC
Release voltage	1 V DC	10 V AC
Power consumption DC / AC	0.8 W	7 VA

Insulation

Rated test voltage input/output	4000 Vrms / 1 min
Rated test voltage input output/base	2500 Vrms / 1 min
Overvoltage category	III

General data

Ambient temperature storage (no ice)	-30 ... 100 °C
Ambient temperature operation	-30 ... 80 °C
Pick up time DC control / AC control	1/2 cycle + 1 ms / 40 ms
Release time DC control / AC control	1/2 cycle + 1 ms / 40 ms
Power Factor	> 0.5
Protection degree	IP 00
Dimension	fig. 5.
Weight	180 g
Housing material	PBT

Product reference (o.r. = on request)

Description	Type	A		
		080	100	125
DC Control				
1 NO, Led, RC Protection	SP1PXN-TZX0240N...X/DC4-32V		✓	✓
1 NO, Led, MOV and RC protection	SP1PXN-TZX0240V...X/DC4-32V		o.r.	o.r.
1 NO, Led, TVS and RC protection	SP1PXN-TZX0240T...X/DC4-32V		✓	✓
AC Control				
1 NO, Led, RC Protection	SP1PXN-TZX0240N...X/AC90-280V		✓	✓
1 NO, Led, MOV and RC protection	SP1PXN-TZX0240V...X/AC90-280V		o.r.	o.r.
1 NO, Led, TVS and RC protection	SP1PXN-TZX0240T...X/AC90-280V		✓	✓

Complete load current to complete product reference

(*1) Maximum operating voltage allowed by MOV: 300 V AC

(*2) TVS protection voltage: 480 V

Heatsinks (to be used either with SP1P/pad or SP1/grease). Further heatsink options are shown in the following chapter.

Heatsinks	Thermal resistance [°C/W]	Dimensions H x W x D (mm)	Mounting type
HS_006	0.6	148.5x55x59	DIN rail (with clip)
HS_015	0.6	106x80x96	Panel (with screws)
HS_007	0.8	122.5x81x100.5	DIN rail (with clip)

Accessories

Thermal conducting pad	SP1P/pad
Thermal conducting grease	SP1/grease
Transparent cover can be removed after assembly	SP1PXN/cover



fig. 1. Wiring diagram

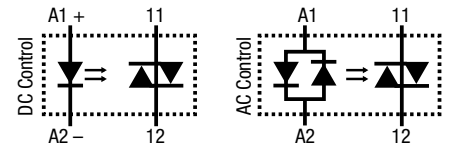


fig. 2. Thermal derating curve 80 A

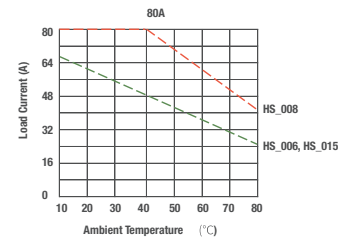


fig. 3. Thermal derating curve 100 A

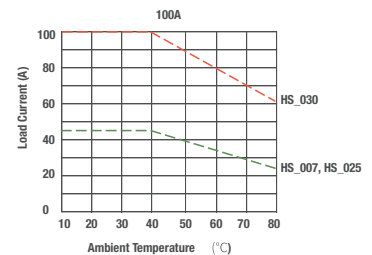


fig. 4. Thermal derating curve 125 A

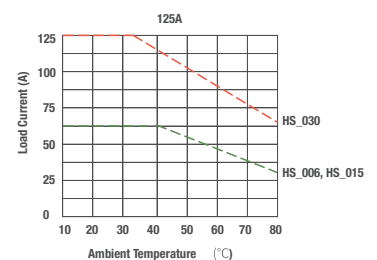
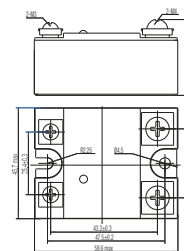


fig. 5. Dimension (mm)



Technical approvals, conformities

Standards EN 60950-1, EN 62314



SP1PXN-TIX0240



1 phase | normally open solid state AC up to 280V, 125A | instantaneous | screw IP 00

Main circuit

Output type	⚡ SCR		
Type	Instantaneous		
Rated voltage AC	240		
Output voltage range AC	48 ... 280 V		
Operating frequency	47 ... 63 Hz		
Recommended minimum contact load	100 mA		
Maximum leakage current @ rated voltage A	10 mA		
Maximum voltage drop @ rated current	≤ 1.7 V rms		
Repetitive peak voltage in off-state	600 Vpk		
Maximum off state dv / dt	500 V / μs		
Maximum non repetitive di / dt	50 A/μs		
Contact type	Screw		
Contact	1 NO		
Load current	80 A	100 A	125 A
Thermal derating, refer to:	fig. 2.	fig. 3.	fig. 4.
Inrush current @ 10 ms	1000 A	1250 A	1500 A
I²t @ 10 ms	5000 A²s	7812 A²s	11250 A²s

Control circuit

Operating voltage range	4 ... 32 V DC	90 ... 280 V AC
Maximum input current @ maximum operating voltage	25 mA	25 mA
Pick-up voltage	4 V DC	90 V AC
Release voltage	1 V DC	10 V AC
Power consumption DC / AC	0.8 W	7 VA

Insulation

Rated test voltage input/output	4000 Vrms / 1 min
Rated test voltage input output/base	2500 Vrms / 1 min
Overvoltage category	III

General data

Ambient temperature storage (no ice)	-30 ... 100 °C
Ambient temperature operation	-30 ... 80 °C
Pick up time DC control / AC control	1 ms / 40 ms
Release time DC control / AC control	1/2 cycle + 1 ms / 40 ms
Power Factor	> 0.5
Protection degree	IP 00
Dimension	fig. 5.
Weight	180 g
Housing material	PBT

Product reference (o.r. = on request)

Description	Type	A		
		080	100	125
DC Control				
1 NO, Led, RC Protection	SP1PXN-TIX0240N...X/DC4-32V			
1 NO, Led, MOV and RC protection	SP1PXN-TIX0240V...X/DC4-32V			
1 NO, Led, TVS and RC protection	SP1PXN-TIX0240T...X/DC4-32V			
AC Control				
1 NO, Led, RC Protection	SP1PXN-TIX0240N...X/AC90-280V			
1 NO, Led, MOV and RC protection	SP1PXN-TIX0240V...X/AC90-280V			
1 NO, Led, TVS and RC protection	SP1PXN-TIX0240T...X/AC90-280V			

Complete load current to complete product reference
 (*1) Maximum operating voltage allowed by MOV: 300 V AC
 (*2) TVS protection voltage: 480 V

Heatsinks (to be used either with SP1P/pad or SP1/grease). Further heatsink options are shown in the following chapter.

Heatsinks	Thermal resistance [°C/W]	Dimensions H x W x D (mm)	Mounting type
HS_006	0.6	148.5x55x59	DIN rail (with clip)
HS_015	0.6	106x80x96	Panel (with screws)
HS_007	0.8	122.5x81x100.5	DIN rail (with clip)

Accessories

Thermal conducting pad	SP1P/pad
Thermal conducting grease	SP1/grease
Transparent cover can be removed after assembly	SP1PXN/cover



fig. 1. Wiring diagram

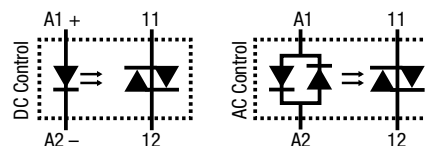


fig. 2. Thermal derating curve 80 A

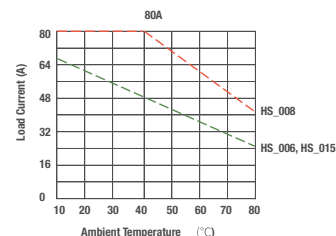


fig. 3. Thermal derating curve 100 A

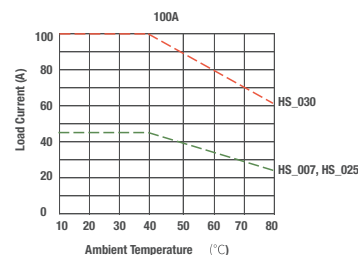


fig. 4. Thermal derating curve 125 A

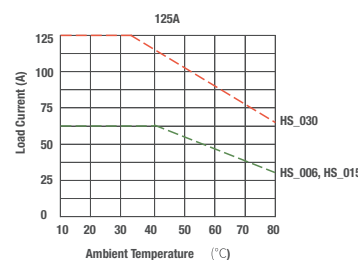
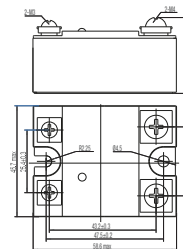


fig. 5. Dimension (mm)



Technical approvals, conformities

Standards EN 60950-1, EN 62314



SP1PXN-TZX0480

1 phase | normally open solid state AC up to 530V, 20A | synchr zero | screw IP 00



Main circuit

Output type	⚡ Triac		
Type	Synchronized zero		
Rated voltage AC	480		
Output voltage range AC	48 ... 530 V		
Operating frequency	47 ... 63 Hz		
Recommended minimum contact load	100 mA		
Maximum leakage current @ rated voltage A	10 mA		
Maximum voltage drop @ rated current	≤ 1.7 V rms		
Repetitive peak voltage in off-state	1200 Vpk		
Maximum off state dv / dt	200 V / μs		
Maximum non repetitive di / dt	50 A/μs		
Contact type	Screw		
Contact	1 NO		
Load current	10 A	15 A	20 A
Thermal derating, refer to:	fig. 2.	fig. 3.	fig. 4.
Inrush current @ 10 ms	120 A	160 A	200 A
I ² t @ 10 ms	72 A ² s	128 A ² s	200 A ² s

Control circuit

Operating voltage range	4 ... 32 V DC	90 ... 280 V AC
Maximum input current @ maximum operating voltage	25 mA	25 mA
Pick-up voltage	4 V DC	90 V AC
Release voltage	1 V DC	10 V AC
Power consumption DC / AC	0.8 W	7 VA

Insulation

Rated test voltage input/output	4000 Vrms / 1 min
Rated test voltage input output/base	2500 Vrms / 1 min
Overvoltage category	III

General data

Ambient temperature storage (no ice)	-30 ... 100 °C
Ambient temperature operation	-30 ... 80 °C
Pick up time DC control / AC control	1/2 cycle + 1 ms / 40 ms
Release time DC control / AC control	1/2 cycle + 1 ms / 40 ms
Power Factor	> 0.5
Protection degree	IP 00
Dimension	fig. 5.
Weight	100 g
Housing material	PBT

Product reference (o.r. = on request)

Description	Type	A		
		010	015	020
DC Control				
1 NO, Led, RC Protection	SP1PXN-TZX0480N...X/DC4-32V	o.r.	o.r.	o.r.
1 NO, Led, MOV and RC protection	SP1PXN-TZX0480V...X/DC4-32V	o.r.	o.r.	o.r.
1 NO, Led, TVS and RC protection	SP1PXN-TZX0480T...X/DC4-32V	o.r.	o.r.	o.r.
AC Control				
1 NO, Led, RC Protection	SP1PXN-TZX0480N...X/AC90-280V	o.r.	o.r.	o.r.
1 NO, Led, MOV and RC protection	SP1PXN-TZX0480V...X/AC90-280V	o.r.	o.r.	o.r.
1 NO, Led, TVS and RC protection	SP1PXN-TZX0480T...X/AC90-280V	o.r.	o.r.	o.r.

Complete load current to complete product reference

(*1) Maximum operating voltage allowed by MOV: 550 V AC

(*2) TVS protection voltage: 960 V

Heatsinks (to be used either with SP1P/pad or SP1/grease). Further heatsink options are shown in the following chapter.

Heatsinks	Thermal resistance [°C/W]	Dimensions H x W x D (mm)	Mounting type
HS_003	1.9	106x96x110	DIN rail (with clip)
HS_012	2.1	106x96x50	Panel (with screws)
HS_005	1.6	122x55x59	DIN rail (with clip)

Accessories

Thermal conducting pad	SP1P/pad
Thermal conducting grease	SP1/grease
Transparent cover can be removed after assembly	SP1PXN/cover



fig. 1. Wiring diagram

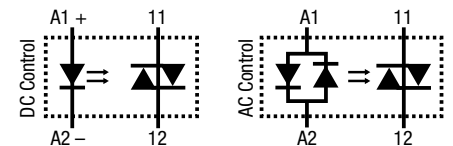


fig. 2. Thermal derating curve 10 A

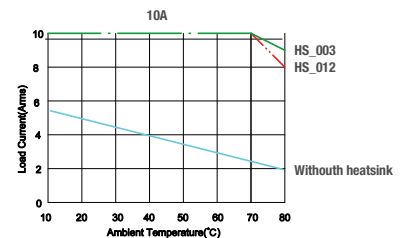


fig. 3. Thermal derating curve 15 A

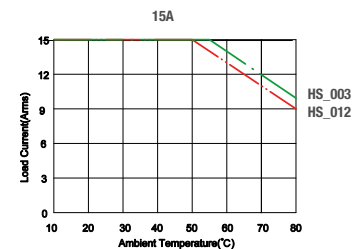


fig. 4. Thermal derating curve 20 A

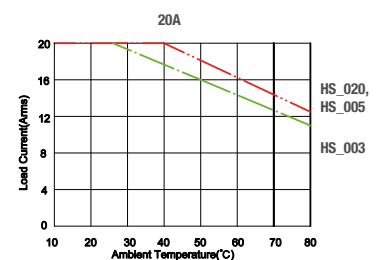
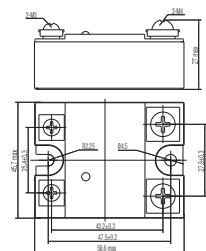


fig. 5. Dimension (mm)



Technical approvals, conformities

Standards EN 60950-1, EN 62314



SP1PXN-TIX0480

1 phase | normally open solid state AC up to 530V, 20A | instantaneous | screw IP 00

Main circuit

Output type	⚡ Triac		
Type	Instantaneous		
Rated voltage AC	480		
Output voltage range AC	48 ... 530 V		
Operating frequency	47 ... 63 Hz		
Recommended minimum contact load	100 mA		
Maximum leakage current @ rated voltage A	10 mA		
Maximum voltage drop @ rated current	≤ 1.7 V rms		
Repetitive peak voltage in off-state	1200 Vpk		
Maximum off state dv / dt	200 V / μs		
Maximum non repetitive di / dt	50 A/μs		
Contact type	Screw		
Contact	1 NO		
Load current	10 A	15 A	20 A
Thermal derating, refer to:	fig. 2.	fig. 3.	fig. 4.
Inrush current @ 10 ms	120 A	160 A	200 A
I²t @ 10 ms	72 A²s	128 A²s	200 A²s

Control circuit

Operating voltage range	4 ... 32 V DC	90 ... 280 V AC
Maximum input current @ maximum operating voltage	25 mA	25 mA
Pick-up voltage	4 V DC	90 V AC
Release voltage	1 V DC	10 V AC
Power consumption DC / AC	0.8 W	7 VA

Insulation

Rated test voltage input/output	4000 Vrms / 1 min
Rated test voltage input output/base	2500 Vrms / 1 min
Overvoltage category	III

General data

Ambient temperature storage (no ice)	-30 ... 100 °C
Ambient temperature operation	-30 ... 80 °C
Pick up time DC control / AC control	1 ms / 40 ms
Release time DC control / AC control	1/2 cycle + 1 ms / 40 ms
Power Factor	> 0.5
Protection degree	IP 00
Dimension	fig. 5.
Weight	100 g
Housing material	PBT

Product reference (o.r. = on request)

Description	Type	A		
		010	015	020
DC Control				
1 NO, Led, RC Protection	SP1PXN-TIX0480N...X/DC4-32V	o.r.	o.r.	o.r.
1 NO, Led, MOV and RC protection	SP1PXN-TIX0480V...X/DC4-32V	o.r.	o.r.	o.r.
1 NO, Led, TVS and RC protection	SP1PXN-TIX0480T...X/DC4-32V	o.r.	o.r.	o.r.
AC Control				
1 NO, Led, RC Protection	SP1PXN-TIX0480N...X/AC90-280V	o.r.	o.r.	o.r.
1 NO, Led, MOV and RC protection	SP1PXN-TIX0480V...X/AC90-280V	o.r.	o.r.	o.r.
1 NO, Led, TVS and RC protection	SP1PXN-TIX0480T...X/AC90-280V	o.r.	o.r.	o.r.

Complete load current to complete product reference

(*1) Maximum operating voltage allowed by MOV: 550 V AC

(*2) TVS protection voltage: 960 V

Heatsinks (to be used either with SP1P/pad or SP1/grease). Further heatsink options are shown in the following chapter.

Heatsinks	Thermal resistance [°C/W]	Dimensions H x W x D (mm)	Mounting type
HS_003	1.9	106x96x110	DIN rail (with clip)
HS_012	2.1	106x96x50	Panel (with screws)
HS_005	1.6	122x55x59	DIN rail (with clip)

Accessories

Thermal conducting pad	SP1P/pad
Thermal conducting grease	SP1/grease
Transparent cover can be removed after assembly	SP1PXN/cover



fig. 1. Wiring diagram

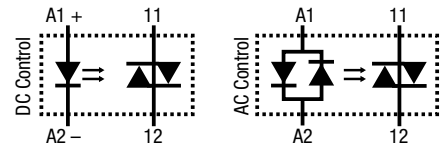


fig. 2. Thermal derating curve 10 A

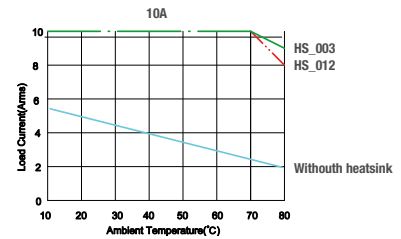


fig. 3. Thermal derating curve 15 A

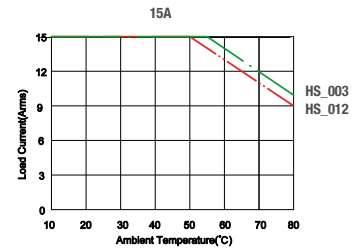


fig. 4. Thermal derating curve 20 A

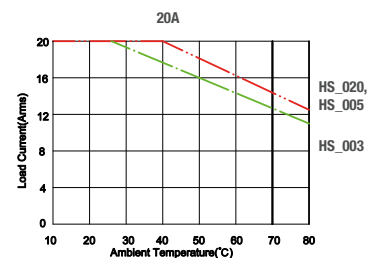
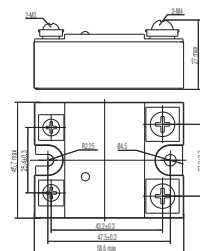


fig. 5. Dimension (mm)



Technical approvals, conformities

Standards EN 60950-1, EN 62314

Approvals

SP1PXN-TZX0480

1 phase | normally open solid state AC up to 530V, 60A | synchr zero | screw IP 00



Main circuit

Output type	⚡ SCR		
Type	Synchronized zero		
Rated voltage AC	480		
Output voltage range AC	48 ... 530 V		
Operating frequency	47 ... 63 Hz		
Recommended minimum contact load	100 mA		
Maximum leakage current @ rated voltage A	10 mA		
Maximum voltage drop @ rated current	≤ 1.7 V rms		
Repetitive peak voltage in off-state	1200 Vpk		
Maximum off state dv / dt	500 V / μs		
Maximum non repetitive di / dt	50 A/μs		
Contact type	Screw		
Contact	1 NO		
Load current	25 A	40 A	60 A
Thermal derating, refer to:	fig. 2.	fig. 3.	fig. 4.
Inrush current @ 10 ms	250 A	500 A	700 A
I ² t @ 10 ms	312 A²s	1250 A²s	2450 A²s

Control circuit

Operating voltage range	4 ... 32 V DC	90 ... 280 V AC
Maximum input current @ maximum operating voltage	25 mA	25 mA
Pick-up voltage	4 V DC	90 V AC
Release voltage	1 V DC	10 V AC
Power consumption DC / AC	0.8 W	7 VA

Insulation

Rated test voltage input/output	4000 Vrms / 1 min
Rated test voltage input output/base	2500 Vrms / 1 min
Overvoltage category	III

General data

Ambient temperature storage (no ice)	-30 ... 100 °C
Ambient temperature operation	-30 ... 80 °C
Pick up time DC control / AC control	1/2 cycle + 1 ms / 40 ms
Release time DC control / AC control	1/2 cycle + 1 ms / 40 ms
Power Factor	> 0.5
Protection degree	IP 00
Dimension	fig. 5.
Weight	100 g
Housing material	PBT

Product reference (o.r. = on request)

Description	Type	A		
		025	040	060
DC Control				
1 NO, Led, RC Protection	SP1PXN-TZX0480N...X/DC4-32V	o.r.	o.r.	o.r.
1 NO, Led, MOV and RC protection	SP1PXN-TZX0480V...X/DC4-32V	o.r.	o.r.	o.r.
1 NO, Led, TVS and RC protection	SP1PXN-TZX0480T...X/DC4-32V	o.r.	o.r.	o.r.
AC Control				
1 NO, Led, RC Protection	SP1PXN-TZX0480N...X/AC90-280V	o.r.	o.r.	o.r.
1 NO, Led, MOV and RC protection	SP1PXN-TZX0480V...X/AC90-280V	o.r.	o.r.	o.r.
1 NO, Led, TVS and RC protection	SP1PXN-TZX0480T...X/AC90-280V	o.r.	o.r.	o.r.

Complete load current to complete product reference

(*1) Maximum operating voltage allowed by MOV: 550 V AC

(*2) TVS protection voltage: 960 V

Heatsinks (to be used either with SP1P/pad or SP1/grease). Further heatsink options are shown in the following chapter.

Heatsinks	Thermal resistance [°C/W]	Dimensions H x W x D (mm)	Mounting type
HS_005	1.6	122x55x59	DIN rail (with clip)
HS_020	1.6	106x50x96	Panel (with screws)
HS_007	0.8	122.5x81x100.5	DIN rail (with clip)

Accessories

Thermal conducting pad	SP1P/pad
Thermal conducting grease	SP1/grease
Transparent cover can be removed after assembly	SP1PXN/cover



fig. 1. Wiring diagram

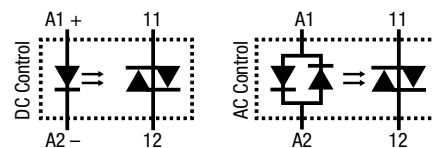


fig. 2. Thermal derating curve 25 A

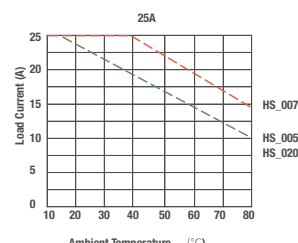


fig. 3. Thermal derating curve 40 A

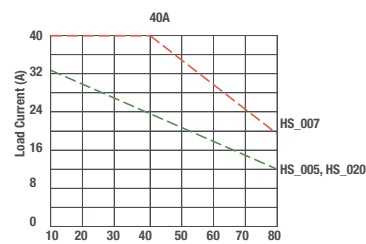


fig. 4. Thermal derating curve 60 A

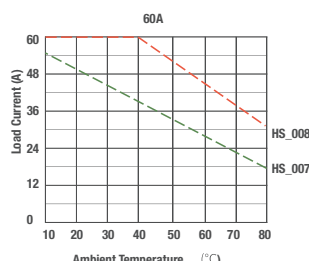
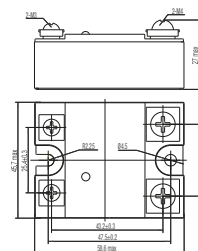


fig. 5. Dimension (mm)



Technical approvals, conformities

Standards EN 60950-1, EN 62314



SP1PXN-TIX0480

1 phase | normally open solid state AC up to 530V, 60A | instantaneous | screw IP 00



Main circuit

Output type	⚡ SCR		
Type	Instantaneous		
Rated voltage AC	480		
Output voltage range AC	48 ... 530 V		
Operating frequency	47 ... 63 Hz		
Recommended minimum contact load	100 mA		
Maximum leakage current @ rated voltage A	10 mA		
Maximum voltage drop @ rated current	≤ 1.7 V rms		
Repetitive peak voltage in off-state	1200 Vpk		
Maximum off state dv / dt	500 V / μs		
Maximum non repetitive di / dt	50 A/μs		
Contact type	Screw		
Contact	1 NO		
Load current	25 A	40 A	60 A
Thermal derating, refer to:	fig. 2.	fig. 3.	fig. 4.
Inrush current @ 10 ms	250 A	500 A	700 A
I²t @ 10 ms	312 A²s	1250 A²s	2450 A²s

Control circuit

Operating voltage range	4 ... 32 V DC	90 ... 280 V AC
Maximum input current @ maximum operating voltage	25 mA	25 mA
Pick-up voltage	4 V DC	90 V AC
Release voltage	1 V DC	10 V AC
Power consumption DC / AC	0.8 W	7 VA

Insulation

Rated test voltage input/output	4000 Vrms / 1 min
Rated test voltage input output/base	2500 Vrms / 1 min
Ovoltage category	III

General data

Ambient temperature storage (no ice)	-30 ... 100 °C
Ambient temperature operation	-30 ... 80 °C
Pick up time DC control / AC control	1 ms / 40 ms
Release time DC control / AC control	1/2 cycle + 1 ms / 40 ms
Power Factor	> 0.5
Protection degree	IP 00
Dimension	fig. 5.
Weight	100 g
Housing material	PBT

Product reference (o.r. = on request)

Description	Type	A		
		025	040	060
DC Control				
1 NO, Led, RC Protection	SP1PXN-TIX0480N...X/DC4-32V	o.r.	o.r.	o.r.
1 NO, Led, MOV and RC protection	SP1PXN-TIX0480V...X/DC4-32V	o.r.	o.r.	o.r.
1 NO, Led, TVS and RC protection	SP1PXN-TIX0480T...X/DC4-32V	o.r.	o.r.	o.r.
AC Control				
1 NO, Led, RC Protection	SP1PXN-TIX0480N...X/AC90-280V	o.r.	o.r.	o.r.
1 NO, Led, MOV and RC protection	SP1PXN-TIX0480V...X/AC90-280V	o.r.	o.r.	o.r.
1 NO, Led, TVS and RC protection	SP1PXN-TIX0480T...X/AC90-280V	o.r.	o.r.	o.r.

Complete load current to complete product reference
 (*1) Maximum operating voltage allowed by MOV: 550 V AC
 (*2) TVS protection voltage: 960 V

Heatsinks (to be used either with SP1P/pad or SP1/grease). Further heatsink options are shown in the following chapter.

Heatsinks	Thermal resistance [°C/W]	Dimensions H x W x D (mm)	Mounting type
HS_005	1.6	122x55x59	DIN rail (with clip)
HS_020	1.6	106x50x96	Panel (with screws)
HS_007	0.8	122.5x81x100.5	DIN rail (with clip)

Accessories

Thermal conducting pad	SP1P/pad
Thermal conducting grease	SP1/grease
Transparent cover can be removed after assembly	SP1PXN/cover



fig. 1. Wiring diagram

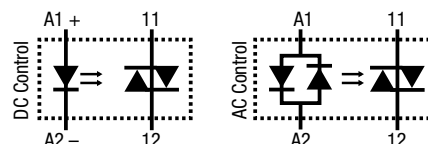


fig. 2. Thermal derating curve 25 A

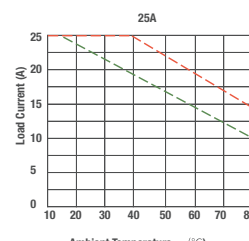


fig. 3. Thermal derating curve 40 A

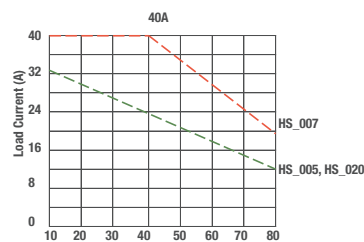


fig. 4. Thermal derating curve 60 A

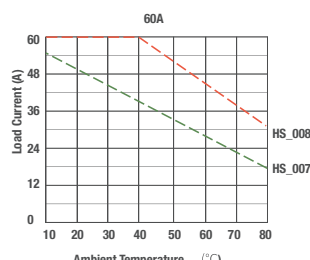
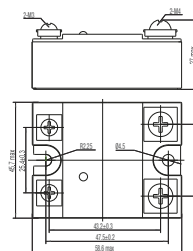


fig. 5. Dimension (mm)



Technical approvals, conformities

Standards EN 60950-1, EN 62314



SP1PXN-TZX0480

1 phase | normally open solid state AC up to 530V, 125A | synchr zero | screw IP 00



3 SSR panel or DIN rail mounted

3

Main circuit

Output type	⚡ SCR		
Type	Synchronized zero		
Rated voltage AC	480		
Output voltage range AC	48 ... 530 V		
Operating frequency	47 ... 63 Hz		
Recommended minimum contact load	100 mA		
Maximum leakage current @ rated voltage A	10 mA		
Maximum voltage drop @ rated current	≤ 1.7 V rms		
Repetitive peak voltage in off-state	1200 Vpk		
Maximum off state dv / dt	500 V / μs		
Maximum non repetitive di / dt	50 A/μs		
Contact type	Screw		
Contact	1 NO		
Load current	80 A	100 A	125 A
Thermal derating, refer to:	fig. 2.	fig. 3.	fig. 4.
Inrush current @ 10 ms	1000 A	1250 A	1500 A
I ² t @ 10 ms	5000 A ² s	7812 A ² s	11250 A ² s

Control circuit

Operating voltage range	4 ... 32 V DC	90 ... 280 V AC
Maximum input current @ maximum operating voltage	25 mA	25 mA
Pick-up voltage	4 V DC	90 V AC
Release voltage	1 V DC	10 V AC
Power consumption DC / AC	0.8 W	7 VA

Insulation

Rated test voltage input/output	4000 Vrms / 1 min
Rated test voltage input output/base	2500 Vrms / 1 min
Overvoltage category	III

General data

Ambient temperature storage (no ice)	-30 ... 100 °C
Ambient temperature operation	-30 ... 80 °C
Pick up time DC control / AC control	1/2 cycle + 1 ms / 40 ms
Release time DC control / AC control	1/2 cycle + 1 ms / 40 ms
Power Factor	> 0.5
Protection degree	IP 00
Dimension	fig. 5.
Weight	180 g
Housing material	PBT

Product reference (o.r. = on request)

Description	Type	A		
		080	100	125
DC Control				
1 NO, Led, RC Protection	SP1PXN-TZX0480N...X/DC4-32V		✓	✓
1 NO, Led, MOV and RC protection	SP1PXN-TZX0480V...X/DC4-32V		o.r.	o.r.
1 NO, Led, TVS and RC protection	SP1PXN-TZX0480T...X/DC4-32V		✓	✓
AC Control				
1 NO, Led, RC Protection	SP1PXN-TZX0480N...X/AC90-280V		✓	✓
1 NO, Led, MOV and RC protection	SP1PXN-TZX0480V...X/AC90-280V		o.r.	o.r.
1 NO, Led, TVS and RC protection	SP1PXN-TZX0480T...X/AC90-280V		✓	✓

Complete load current to complete product reference

(*1) Maximum operating voltage allowed by MOV: 550 V AC

(*2) TVS protection voltage: 960 V

Heatsinks (to be used either with SP1P/pad or SP1/grease). Further heatsink options are shown in the following chapter.

Heatsinks	Thermal resistance [°C/W]	Dimensions H x W x D (mm)	Mounting type
HS_006	0.6	148.5x55x59	DIN rail (with clip)
HS_015	0.6	106x80x96	Panel (with screws)
HS_007	0.8	122.5x81x100.5	DIN rail (with clip)

Accessories

Thermal conducting pad	SP1P/pad
Thermal conducting grease	SP1/grease
Transparent cover can be removed after assembly	SP1PXN/cover



fig. 1. Wiring diagram

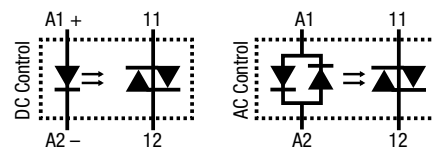


fig. 2. Thermal derating curve 80 A

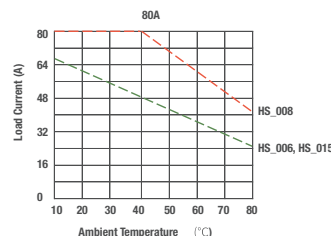


fig. 3. Thermal derating curve 100 A

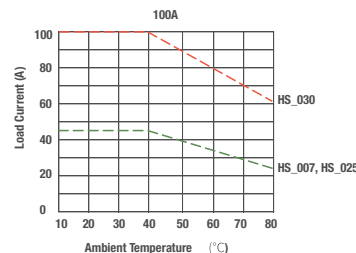


fig. 4. Thermal derating curve 125 A

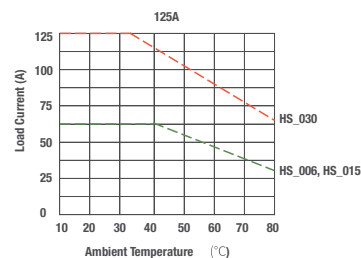
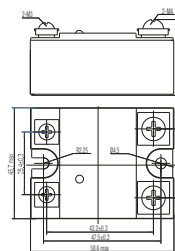


fig. 5. Dimension (mm)



Technical approvals, conformities

Standards EN 60950-1, EN 62314



SP1PXN-TIX0480



1 phase | normally open solid state AC up to 530V, 125A | instantaneous | screw IP 00

Main circuit

Output type	⚡ SCR		
Type	Instantaneous		
Rated voltage AC	480		
Output voltage range AC	48 ... 530 V		
Operating frequency	47 ... 63 Hz		
Recommended minimum contact load	100 mA		
Maximum leakage current @ rated voltage A	10 mA		
Maximum voltage drop @ rated current	≤ 1.7 V rms		
Repetitive peak voltage in off-state	1200 Vpk		
Maximum off state dv / dt	500 V / μs		
Maximum non repetitive di / dt	50 A/μs		
Contact type	Screw		
Contact	1 NO		
Load current	80 A	100 A	125 A
Thermal derating, refer to:	fig. 2.	fig. 3.	fig. 4.
Inrush current @ 10 ms	1000 A	1250 A	1500 A
I²t @ 10 ms	5000 A²s	7812 A²s	11250 A²s

Control circuit

Operating voltage range	4 ... 32 V DC	90 ... 280 V AC
Maximum input current @ maximum operating voltage	25 mA	25 mA
Pick-up voltage	4 V DC	90 V AC
Release voltage	1 V DC	10 V AC
Power consumption DC / AC	0.8 W	7 VA

Insulation

Rated test voltage input/output	4000 Vrms / 1 min
Rated test voltage input output/base	2500 Vrms / 1 min
Overvoltage category	III

General data

Ambient temperature storage (no ice)	-30 ... 100 °C
Ambient temperature operation	-30 ... 80 °C
Pick up time DC control / AC control	1 ms / 40 ms
Release time DC control / AC control	1/2 cycle + 1 ms / 40 ms
Power Factor	> 0.5
Protection degree	IP 00
Dimension	fig. 5.
Weight	180 g
Housing material	PBT

Product reference (o.r. = on request)

Description	Type	A		
		080	100	125
DC Control				
1 NO, Led, RC Protection	SP1PXN-TIX0480N...X/DC4-32V		o.r.	o.r.
1 NO, Led, MOV and RC protection	SP1PXN-TIX0480V...X/DC4-32V		o.r.	o.r.
1 NO, Led, TVS and RC protection	SP1PXN-TIX0480T...X/DC4-32V		o.r.	o.r.
AC Control				
1 NO, Led, RC Protection	SP1PXN-TIX0480N...X/AC90-280V		o.r.	o.r.
1 NO, Led, MOV and RC protection	SP1PXN-TIX0480V...X/AC90-280V		o.r.	o.r.
1 NO, Led, TVS and RC protection	SP1PXN-TIX0480T...X/AC90-280V		o.r.	o.r.

Complete load current to complete product reference
 (*1) Maximum operating voltage allowed by MOV: 550 V AC
 (*2) TVS protection voltage: 960 V

Heatsinks (to be used either with SP1P/pad or SP1/grease). Further heatsink options are shown in the following chapter.

Heatsinks	Thermal resistance [°C/W]	Dimensions H x W x D (mm)	Mounting type
HS_006	0.6	148.5x55x59	DIN rail (with clip)
HS_015	0.6	106x80x96	Panel (with screws)
HS_007	0.8	122.5x81x100.5	DIN rail (with clip)

Accessories

Thermal conducting pad	SP1P/pad
Thermal conducting grease	SP1/grease
Transparent cover can be removed after assembly	SP1PXN/cover



fig. 1. Wiring diagram

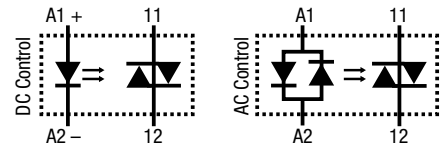


fig. 2. Thermal derating curve 80 A

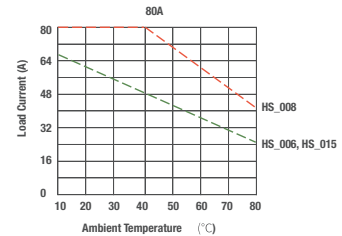


fig. 3. Thermal derating curve 100 A

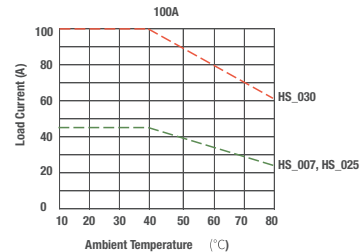


fig. 4. Thermal derating curve 125 A

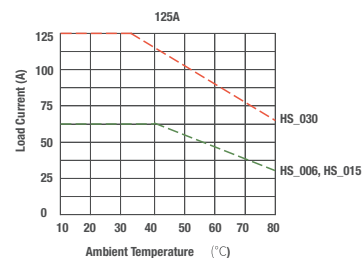
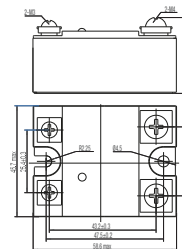


fig. 5. Dimension (mm)



Technical approvals, conformities

Standards EN 60950-1, EN 62314



SP1PXN-TZX0600

1 phase | normally open solid state AC up to 660V, 20A | synchr zero | screw IP 00



Main circuit

Output type	⚡ Triac		
Type	Synchronized zero		
Rated voltage AC	600		
Output voltage range AC	48 ... 660 V		
Operating frequency	47 ... 63 Hz		
Recommended minimum contact load	100 mA		
Maximum leakage current @ rated voltage A	10 mA		
Maximum voltage drop @ rated current	≤ 1.7 V rms		
Repetitive peak voltage in off-state	1600 Vpk		
Maximum off state dv / dt	200 V / μs		
Maximum non repetitive di / dt	50 A/μs		
Contact type	Screw		
Contact	1 NO		
Load current	10 A	15 A	20 A
Thermal derating, refer to:	fig. 2.	fig. 3.	fig. 4.
Inrush current @ 10 ms	120 A	160 A	200 A
I ² t @ 10 ms	72 A ² s	128 A ² s	200 A ² s

Control circuit

Operating voltage range	4 ... 32 V DC	90 ... 280 V AC
Maximum input current @ maximum operating voltage	25 mA	25 mA
Pick-up voltage	4 V DC	90 V AC
Release voltage	1 V DC	10 V AC
Power consumption DC / AC	0.8 W	7 VA

Insulation

Rated test voltage input/output	4000 Vrms / 1 min
Rated test voltage input output/base	2500 Vrms / 1 min
Overvoltage category	III

General data

Ambient temperature storage (no ice)	-30 ... 100 °C
Ambient temperature operation	-30 ... 80 °C
Pick up time DC control / AC control	1/2 cycle + 1 ms / 40 ms
Release time DC control / AC control	1/2 cycle + 1 ms / 40 ms
Power Factor	> 0.5
Protection degree	IP 00
Dimension	fig. 5.
Weight	100 g
Housing material	PBT

Product reference (o.r. = on request)

Description	Type	A		
		010	015	020
DC Control				
1 NO, Led, RC Protection	SP1PXN-TZX0600N...X/DC4-32V	o.r.	o.r.	o.r.
1 NO, Led, MOV and RC protection	SP1PXN-TZX0600V...X/DC4-32V	o.r.	o.r.	o.r.
1 NO, Led, TVS and RC protection	SP1PXN-TZX0600T...X/DC4-32V	o.r.	o.r.	o.r.
AC Control				
1 NO, Led, RC Protection	SP1PXN-TZX0600N...X/AC90-280V	o.r.	o.r.	o.r.
1 NO, Led, MOV and RC protection	SP1PXN-TZX0600V...X/AC90-280V	o.r.	o.r.	o.r.
1 NO, Led, TVS and RC protection	SP1PXN-TZX0600T...X/AC90-280V	o.r.	o.r.	o.r.

Complete load current to complete product reference

(*1) Maximum operating voltage allowed by MOV: 680 V AC

(*2) TVS protection voltage: 1100 V

Heatsinks (to be used either with SP1P/pad or SP1/grease). Further heatsink options are shown in the following chapter.

Heatsinks	Thermal resistance [°C/W]	Dimensions H x W x D (mm)	Mounting type
HS_003	1.9	106x96x110	DIN rail (with clip)
HS_012	2.1	106x96x50	Panel (with screws)
HS_005	1.6	122x55x59	DIN rail (with clip)

Accessories

Thermal conducting pad	SP1P/pad
Thermal conducting grease	SP1/grease
Transparent cover can be removed after assembly	SP1PXN/cover



fig. 1. Wiring diagram

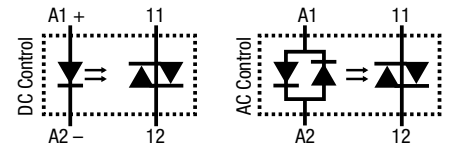


fig. 2. Thermal derating curve 10 A

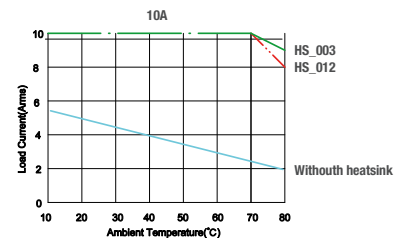


fig. 3. Thermal derating curve 15 A

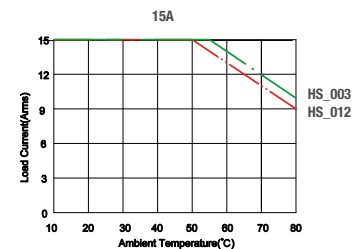


fig. 4. Thermal derating curve 20 A

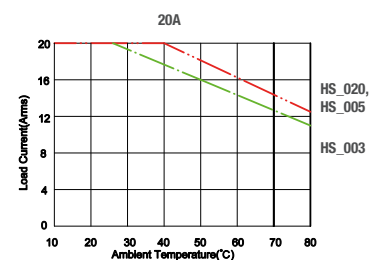
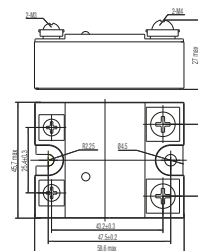


fig. 5. Dimension (mm)



Technical approvals, conformities

Standards EN 60950-1, EN 62314



SP1PXN-TZX0600

1 phase | normally open solid state AC up to 660V, 60A | synchr zero | screw IP 00



3 SSR panel or DIN rail mounted

3

Main circuit

Output type	⚡ SCR		
Type	Synchronized zero		
Rated voltage AC	600		
Output voltage range AC	48 ... 660 V		
Operating frequency	47 ... 63 Hz		
Recommended minimum contact load	100 mA		
Maximum leakage current @ rated voltage A	10 mA		
Maximum voltage drop @ rated current	≤ 1.7 V rms		
Repetitive peak voltage in off-state	1600 Vpk		
Maximum off state dv / dt	500 V / μs		
Maximum non repetitive di / dt	50 A/μs		
Contact type	Screw		
Contact	1 NO		
Load current	25 A	40 A	60 A
Thermal derating, refer to:	fig. 2.	fig. 3.	fig. 4.
Inrush current @ 10 ms	250 A	500 A	700 A
I ² t @ 10 ms	312 A ² s	1250 A ² s	2450 A ² s

Control circuit

Operating voltage range	4 ... 32 V DC	90 ... 280 V AC
Maximum input current @ maximum operating voltage	25 mA	25 mA
Pick-up voltage	4 V DC	90 V AC
Release voltage	1 V DC	10 V AC
Power consumption DC / AC	0.8 W	7 VA

Insulation

Rated test voltage input/output	4000 Vrms / 1 min
Rated test voltage input output/base	2500 Vrms / 1 min
Overvoltage category	III

General data

Ambient temperature storage (no ice)	-30 ... 100 °C
Ambient temperature operation	-30 ... 80 °C
Pick up time DC control / AC control	1/2 cycle + 1 ms / 40 ms
Release time DC control / AC control	1/2 cycle + 1 ms / 40 ms
Power Factor	> 0.5
Protection degree	IP 00
Dimension	fig. 5.
Weight	100 g
Housing material	PBT

Product reference (o.r. = on request)

Description	Type	A		
		025	040	060
DC Control				
1 NO, Led, RC Protection	SP1PXN-TZX0600N...X/DC4-32V	o.r.	o.r.	o.r.
1 NO, Led, MOV and RC protection	SP1PXN-TZX0600V...X/DC4-32V	o.r.	o.r.	o.r.
1 NO, Led, TVS and RC protection	SP1PXN-TZX0600T...X/DC4-32V	o.r.	o.r.	o.r.
AC Control				
1 NO, Led, RC Protection	SP1PXN-TZX0600N...X/AC90-280V	o.r.	o.r.	o.r.
1 NO, Led, MOV and RC protection	SP1PXN-TZX0600V...X/AC90-280V	o.r.	o.r.	o.r.
1 NO, Led, TVS and RC protection	SP1PXN-TZX0600T...X/AC90-280V	o.r.	o.r.	o.r.

Complete load current to complete product reference

(*1) Maximum operating voltage allowed by MOV: 680 V AC

(*2) TVS protection voltage: 1100 V

Heatsinks (to be used either with SP1P/pad or SP1/grease). Further heatsink options are shown in the following chapter.

Heatsinks	Thermal resistance [°C/W]	Dimensions H x W x D (mm)	Mounting type
HS_005	1.6	122x55x59	DIN rail (with clip)
HS_020	1.6	106x50x96	Panel (with screws)
HS_007	0.8	122.5x81x100.5	DIN rail (with clip)

Accessories

Thermal conducting pad	SP1P/pad
Thermal conducting grease	SP1/grease
Transparent cover can be removed after assembly	SP1PXN/cover



fig. 1. Wiring diagram

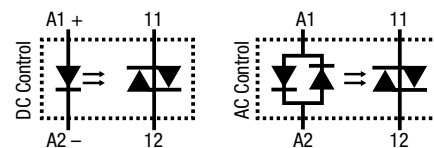


fig. 2. Thermal derating curve 25 A

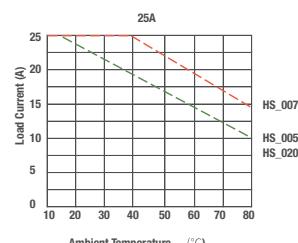


fig. 3. Thermal derating curve 40 A

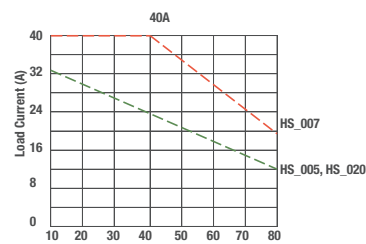


fig. 4. Thermal derating curve 60 A

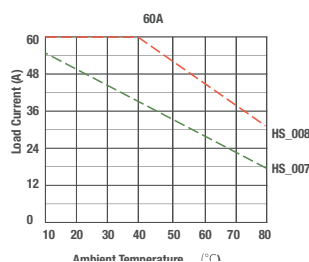
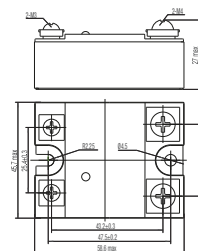


fig. 5. Dimension (mm)



Technical approvals, conformities

Standards EN 60950-1, EN 62314



SP1PXN-TIX0600



1 phase | normally open solid state AC up to 660V, 60A | instantaneous | screw IP 00

Main circuit

Output type	⚡ SCR		
Type	Instantaneous		
Rated voltage AC	600		
Output voltage range AC	48 ... 660 V		
Operating frequency	47 ... 63 Hz		
Recommended minimum contact load	100 mA		
Maximum leakage current @ rated voltage A	10 mA		
Maximum voltage drop @ rated current	≤ 1.7 V rms		
Repetitive peak voltage in off-state	1600 Vpk		
Maximum off state dv / dt	500 V / μs		
Maximum non repetitive di / dt	50 A/μs		
Contact type	Screw		
Contact	1 NO		
Load current	25 A	40 A	60 A
Thermal derating, refer to:	fig. 2.	fig. 3.	fig. 4.
Inrush current @ 10 ms	250 A	500 A	700 A
I²t @ 10 ms	312 A²s	1250 A²s	2450 A²s

Control circuit

Operating voltage range	4 ... 32 V DC	90 ... 280 V AC
Maximum input current @ maximum operating voltage	25 mA	25 mA
Pick-up voltage	4 V DC	90 V AC
Release voltage	1 V DC	10 V AC
Power consumption DC / AC	0.8 W	7 VA

Insulation

Rated test voltage input/output	4000 Vrms / 1 min
Rated test voltage input output/base	2500 Vrms / 1 min
Overvoltage category	III

General data

Ambient temperature storage (no ice)	-30 ... 100 °C
Ambient temperature operation	-30 ... 80 °C
Pick up time DC control / AC control	1 ms / 40 ms
Release time DC control / AC control	1/2 cycle + 1 ms / 40 ms
Power Factor	> 0.5
Protection degree	IP 00
Dimension	fig. 5.
Weight	100 g
Housing material	PBT

Product reference (o.r. = on request)

Description	Type	A		
		025	040	060
DC Control				
1 NO, Led, RC Protection	SP1PXN-TIX0600N...X/DC4-32V	o.r.	o.r.	o.r.
1 NO, Led, MOV and RC protection	SP1PXN-TIX0600V...X/DC4-32V	o.r.	o.r.	o.r.
1 NO, Led, TVS and RC protection	SP1PXN-TIX0600T...X/DC4-32V	o.r.	o.r.	o.r.
AC Control				
1 NO, Led, RC Protection	SP1PXN-TIX0600N...X/AC90-280V	o.r.	o.r.	o.r.
1 NO, Led, MOV and RC protection	SP1PXN-TIX0600V...X/AC90-280V	o.r.	o.r.	o.r.
1 NO, Led, TVS and RC protection	SP1PXN-TIX0600T...X/AC90-280V	o.r.	o.r.	o.r.

Complete load current to complete product reference
 (*1) Maximum operating voltage allowed by MOV: 680 V AC
 (*2) TVS protection voltage: 1100 V

Heatsinks (to be used either with SP1P/pad or SP1/grease). Further heatsink options are shown in the following chapter.

Heatsinks	Thermal resistance [°C/W]	Dimensions H x W x D (mm)	Mounting type
HS_005	1.6	122x55x59	DIN rail (with clip)
HS_020	1.6	106x50x96	Panel (with screws)
HS_007	0.8	122.5x81x100.5	DIN rail (with clip)

Accessories

Thermal conducting pad	SP1P/pad
Thermal conducting grease	SP1/grease
Transparent cover can be removed after assembly	SP1PXN/cover



fig. 1. Wiring diagram

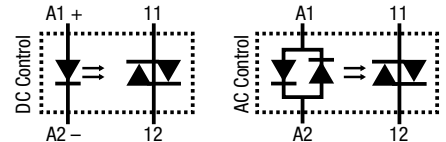


fig. 2. Thermal derating curve 25 A

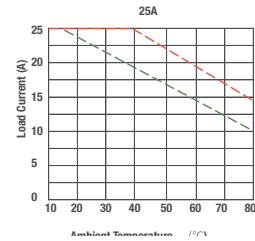


fig. 3. Thermal derating curve 40 A

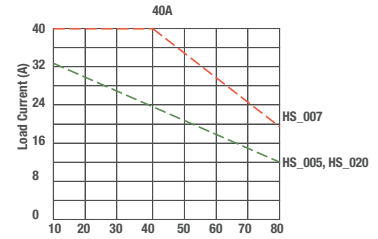


fig. 4. Thermal derating curve 60 A

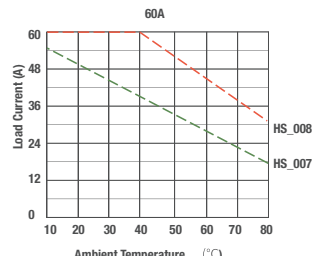
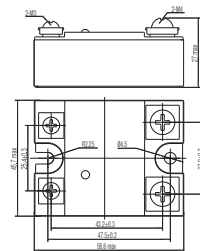


fig. 5. Dimension (mm)



Technical approvals, conformities

Standards EN 60950-1, EN 62314



SP1PXN-TZX0600

1 phase | normally open solid state AC up to 660V, 125A | synchr zero | screw IP 00

Main circuit

Output type	⚡ SCR		
Type	Synchronized zero		
Rated voltage AC	600		
Output voltage range AC	48 ... 660 V		
Operating frequency	47 ... 63 Hz		
Recommended minimum contact load	100 mA		
Maximum leakage current @ rated voltage A	10 mA		
Maximum voltage drop @ rated current	≤ 1.7 V rms		
Repetitive peak voltage in off-state	1600 Vpk		
Maximum off state dv / dt	500 V / μs		
Maximum non repetitive di / dt	50 A/μs		
Contact type	Screw		
Contact	1 NO		
Load current	80 A	100 A	125 A
Thermal derating, refer to:	fig. 2.	fig. 3.	fig. 4.
Inrush current @ 10 ms	1000 A	1250 A	1500 A
I ² t @ 10 ms	5000 A ² s	7812 A ² s	11250 A ² s

Control circuit

Operating voltage range	4 ... 32 V DC	90 ... 280 V AC
Maximum input current @ maximum operating voltage	25 mA	25 mA
Pick-up voltage	4 V DC	90 V AC
Release voltage	1 V DC	10 V AC
Power consumption DC / AC	0.8 W	7 VA

Insulation

Rated test voltage input/output	4000 Vrms / 1 min
Rated test voltage input output/base	2500 Vrms / 1 min
Overvoltage category	III

General data

Ambient temperature storage (no ice)	-30 ... 100 °C
Ambient temperature operation	-30 ... 80 °C
Pick up time DC control / AC control	1/2 cycle + 1 ms / 40 ms
Release time DC control / AC control	1/2 cycle + 1 ms / 40 ms
Power Factor	> 0.5
Protection degree	IP 00
Dimension	fig. 5.
Weight	180 g
Housing material	PBT

Product reference (o.r. = on request)

Description	Type	A		
		080	100	125
DC Control				
1 NO, Led, RC Protection	SP1PXN-TZX0600N...X/DC4-32V		✓	✓
1 NO, Led, MOV and RC protection	SP1PXN-TZX0600V...X/DC4-32V		o.r.	o.r.
1 NO, Led, TVS and RC protection	SP1PXN-TZX0600T...X/DC4-32V		✓	✓
AC Control				
1 NO, Led, RC Protection	SP1PXN-TZX0600N...X/AC90-280V		✓	✓
1 NO, Led, MOV and RC protection	SP1PXN-TZX0600V...X/AC90-280V		o.r.	o.r.
1 NO, Led, TVS and RC protection	SP1PXN-TZX0600T...X/AC90-280V		✓	✓

Complete load current to complete product reference

(*1) Maximum operating voltage allowed by MOV: 680 V AC

(*2) TVS protection voltage: 1100 V

Heatsinks (to be used either with SP1P/pad or SP1/grease). Further heatsink options are shown in the following chapter.

Heatsinks	Thermal resistance [°C/W]	Dimensions H x W x D (mm)	Mounting type
HS_006	0.6	148.5x55x59	DIN rail (with clip)
HS_015	0.6	106x80x96	Panel (with screws)
HS_007	0.8	122.5x81x100.5	DIN rail (with clip)

Accessories

Thermal conducting pad	SP1P/pad
Thermal conducting grease	SP1/grease



fig. 1. Wiring diagram

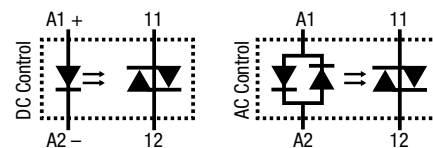


fig. 2. Thermal derating curve 80 A

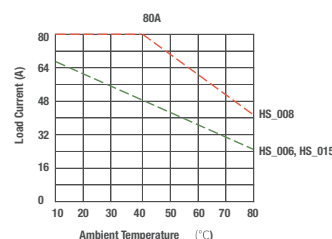


fig. 3. Thermal derating curve 100 A

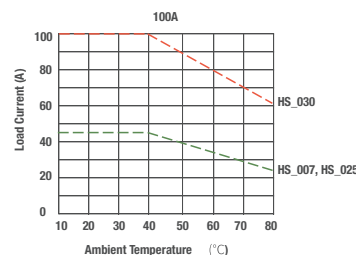


fig. 4. Thermal derating curve 125 A

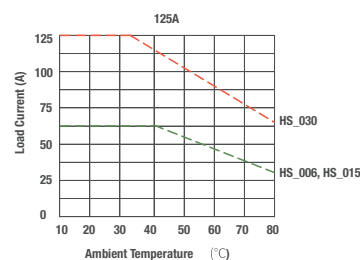
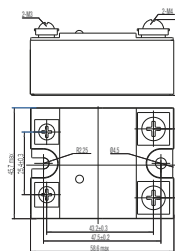


fig. 5. Dimension (mm)



Technical approvals, conformities

Standards EN 60950-1, EN 62314

Approvals

SP1PXN-TIX0600



1 phase | normally open solid state AC up to 660V, 125A | instantaneous | screw IP 00

Main circuit

Output type	⚡ SCR		
Type	Instantaneous		
Rated voltage AC	600		
Output voltage range AC	48 ... 660 V		
Operating frequency	47 ... 63 Hz		
Recommended minimum contact load	100 mA		
Maximum leakage current @ rated voltage A	10 mA		
Maximum voltage drop @ rated current	≤ 1.7 V rms		
Repetitive peak voltage in off-state	1600 Vpk		
Maximum off state dv / dt	500 V / μs		
Maximum non repetitive di / dt	50 A/μs		
Contact type	Screw		
Contact	1 NO		
Load current	80 A	100 A	125 A
Thermal derating, refer to:	fig. 2.	fig. 3.	fig. 4.
Inrush current @ 10 ms	1000 A	1250 A	1500 A
I ² t @ 10 ms	5000 A ² s	7812 A ² s	11250 A ² s

Control circuit

Operating voltage range	4 ... 32 V DC	90 ... 280 V AC
Maximum input current @ maximum operating voltage	25 mA	25 mA
Pick-up voltage	4 V DC	90 V AC
Release voltage	1 V DC	10 V AC
Power consumption DC / AC	0.8 W	7 VA

Insulation

Rated test voltage input/output	4000 Vrms / 1 min
Rated test voltage input output/base	2500 Vrms / 1 min
Overvoltage category	III

General data

Ambient temperature storage (no ice)	-30 ... 100 °C
Ambient temperature operation	-30 ... 80 °C
Pick up time DC control / AC control	1 ms / 40 ms
Release time DC control / AC control	1/2 cycle + 1 ms / 40 ms
Power Factor	> 0.5
Protection degree	IP 00
Dimension	fig. 5.
Weight	180 g
Housing material	PBT

Product reference (o.r. = on request)

Description	Type	A		
		080	100	125
DC Control				
1 NO, Led, RC Protection	SP1PXN-TIX0600N...X/DC4-32V		o.r.	o.r.
1 NO, Led, MOV and RC protection	SP1PXN-TIX0600V...X/DC4-32V		o.r.	o.r.
1 NO, Led, TVS and RC protection	SP1PXN-TIX0600T...X/DC4-32V		o.r.	o.r.
AC Control				
1 NO, Led, RC Protection	SP1PXN-TIX0600N...X/AC90-280V		o.r.	o.r.
1 NO, Led, MOV and RC protection	SP1PXN-TIX0600V...X/AC90-280V		o.r.	o.r.
1 NO, Led, TVS and RC protection	SP1PXN-TIX0600T...X/AC90-280V		o.r.	o.r.

Complete load current to complete product reference
 (*1) Maximum operating voltage allowed by MOV: 680 V AC
 (*2) TVS protection voltage: 1100 V

Heatsinks (to be used either with SP1P/pad or SP1/grease). Further heatsink options are shown in the following chapter.

Heatsinks	Thermal resistance [°C/W]	Dimensions H x W x D (mm)	Mounting type
HS_006	0.6	148.5x55x59	DIN rail (with clip)
HS_015	0.6	106x80x96	Panel (with screws)
HS_007	0.8	122.5x81x100.5	DIN rail (with clip)

Accessories

Thermal conducting pad	SP1P/pad
Thermal conducting grease	SP1/grease



fig. 1. Wiring diagram

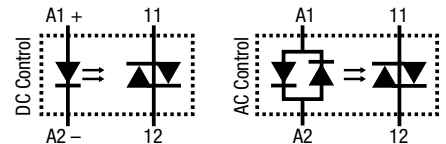


fig. 2. Thermal derating curve 80 A

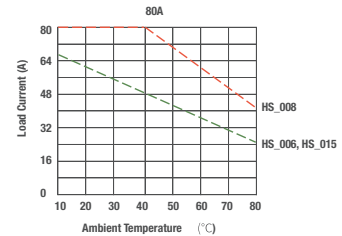


fig. 3. Thermal derating curve 100 A

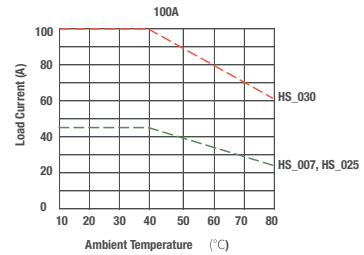


fig. 4. Thermal derating curve 125 A

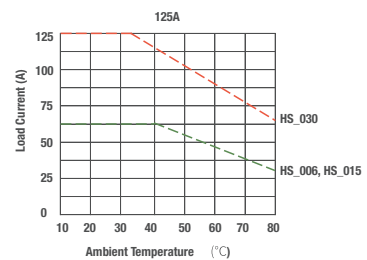
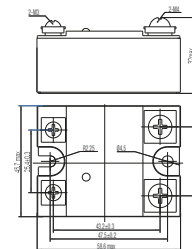


fig. 5. Dimension (mm)



Technical approvals, conformities

Standards EN 60950-1, EN 62314



SP1PXS-TZX0240

1 phase | normally open solid state AC up to 280V, 20A | synchr zero | screw IP 20



Main circuit

Output type	⚡ Triac		
Type	Synchronized zero		
Rated voltage AC	240		
Output voltage range AC	48 ... 280 V		
Operating frequency	47 ... 63 Hz		
Recommended minimum contact load	100 mA		
Maximum leakage current @ rated voltage A	10 mA		
Maximum voltage drop @ rated current	≤ 1.7 V rms		
Repetitive peak voltage in off-state	600 Vpk		
Maximum off state dv / dt	200 V / μs		
Maximum non repetitive di / dt	50 A/μs		
Contact type	Screw		
Contact	1 NO		
Load current	10 A	15 A	20 A
Thermal derating, refer to:	fig. 2.	fig. 3.	fig. 4.
Inrush current @ 10 ms	120 A	160 A	200 A
I ² t @ 10 ms	72 A ² s	128 A ² s	200 A ² s

Control circuit

Operating voltage range	4 ... 32 V DC	90 ... 280 V AC
Maximum input current @ maximum operating voltage	25 mA	25 mA
Pick-up voltage	4 V DC	90 V AC
Release voltage	1 V DC	10 V AC
Power consumption DC / AC	0.8 W	7 VA

Insulation

Rated test voltage input/output	4000 Vrms / 1 min
Rated test voltage input output/base	2500 Vrms / 1 min
Overvoltage category	III

General data

Ambient temperature storage (no ice)	-30 ... 100 °C
Ambient temperature operation	-30 ... 80 °C
Pick up time DC control / AC control	1/2 cycle + 1 ms / 30 ms
Release time DC control / AC control	1/2 cycle + 1 ms / 30 ms
Power Factor	> 0.5
Protection degree	IP 20
Dimension	fig. 5.
Weight	113 g
Housing material	PBT

Product reference (o.r. = on request)

Description	Type	A		
		010	015	020
DC Control				
1 NO, Led, RC Protection	SP1PXS-TZX0240N...X/DC4-32V	o.r.	o.r.	o.r.
1 NO, Led, MOV and RC protection	SP1PXS-TZX0240V...X/DC4-32V	o.r.	o.r.	o.r.
1 NO, Led, TVS and RC protection	SP1PXS-TZX0240T...X/DC4-32V	o.r.	o.r.	o.r.
AC Control				
1 NO, Led, RC Protection	SP1PXS-TZX0240N...X/AC90-280V	o.r.	o.r.	o.r.
1 NO, Led, MOV and RC protection	SP1PXS-TZX0240V...X/AC90-280V	o.r.	o.r.	o.r.
1 NO, Led, TVS and RC protection	SP1PXS-TZX0240T...X/AC90-280V	o.r.	o.r.	o.r.

Complete load current to complete product reference

(*1) Maximum operating voltage allowed by MOV: 300 V AC

(*2) TVS protection voltage: 480 V

Heatsinks (to be used either with SP1P/pad or SP1/grease). Further heatsink options are shown in the following chapter.

Heatsinks	Thermal resistance [°C/W]	Dimensions H x W x D (mm)	Mounting type
HS_003	1.9	106x96x110	DIN rail (with clip)
HS_012	2.1	106x96x50	Panel (with screws)
HS_005	1.6	122x55x59	DIN rail (with clip)

Accessories

Thermal conducting pad	SP1P/pad
Thermal conducting grease	SP1/grease



fig. 1. Wiring diagram

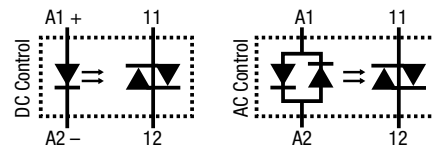


fig. 2. Thermal derating curve 10 A

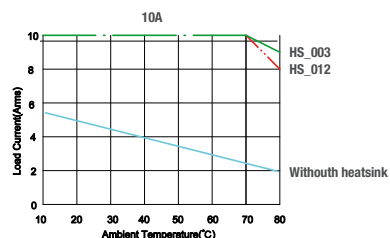


fig. 3. Thermal derating curve 15 A

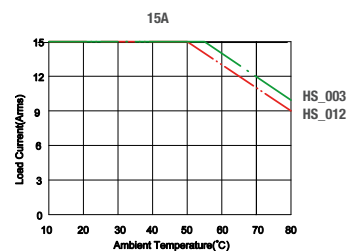


fig. 4. Thermal derating curve 20 A

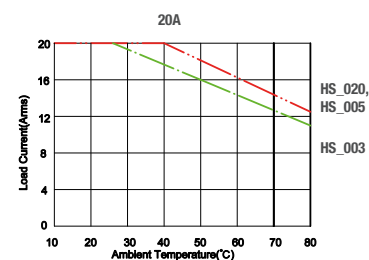
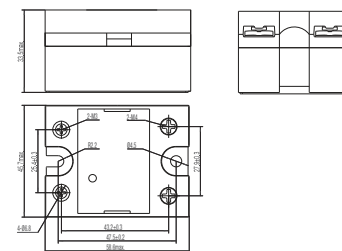


fig. 5. Dimension (mm)



Technical approvals, conformities

Standards EN 60950-1, EN 62314



SP1PXS-TIX0240



1 phase | normally open solid state AC up to 280V, 20A | instantaneous | screw IP 20

Main circuit

Output type	⚡ Triac		
Type	Instantaneous		
Rated voltage AC	240		
Output voltage range AC	48 ... 280 V		
Operating frequency	47 ... 63 Hz		
Recommended minimum contact load	100 mA		
Maximum leakage current @ rated voltage A	10 mA		
Maximum voltage drop @ rated current	≤ 1.7 V rms		
Repetitive peak voltage in off-state	600 Vpk		
Maximum off state dv / dt	200 V / μs		
Maximum non repetitive di / dt	50 A/μs		
Contact type	Screw		
Contact	1 NO		
Load current	10 A	15 A	20 A
Thermal derating, refer to:	fig. 2.	fig. 3.	fig. 4.
Inrush current @ 10 ms	120 A	160 A	200 A
I²t @ 10 ms	72 A²s	128 A²s	200 A²s

Control circuit

Operating voltage range	4 ... 32 V DC	90 ... 280 V AC
Maximum input current @ maximum operating voltage	25 mA	25 mA
Pick-up voltage	4 V DC	90 V AC
Release voltage	1 V DC	10 V AC
Power consumption DC / AC	0.8 W	7 VA

Insulation

Rated test voltage input/output	4000 Vrms / 1 min
Rated test voltage input output/base	2500 Vrms / 1 min
Overvoltage category	III

General data

Ambient temperature storage (no ice)	-30 ... 100 °C
Ambient temperature operation	-30 ... 80 °C
Pick up time DC control / AC control	1 ms / 30 ms
Release time DC control / AC control	1/2 cycle + 1 ms / 30 ms
Power Factor	> 0.5
Protection degree	IP 20
Dimension	fig. 5.
Weight	113 g
Housing material	PBT

Product reference (o.r. = on request)

Description	Type	A		
		010	015	020
DC Control				
1 NO, Led, RC Protection	SP1PXS-TIX0240N...X/DC4-32V	o.r.	o.r.	o.r.
1 NO, Led, MOV and RC protection	SP1PXS-TIX0240V...X/DC4-32V	o.r.	o.r.	o.r.
1 NO, Led, TVS and RC protection	SP1PXS-TIX0240T...X/DC4-32V	o.r.	o.r.	o.r.
AC Control				
1 NO, Led, RC Protection	SP1PXS-TIX0240N...X/AC90-280V	o.r.	o.r.	o.r.
1 NO, Led, MOV and RC protection	SP1PXS-TIX0240V...X/AC90-280V	o.r.	o.r.	o.r.
1 NO, Led, TVS and RC protection	SP1PXS-TIX0240T...X/AC90-280V	o.r.	o.r.	o.r.

Complete load current to complete product reference
 (*1) Maximum operating voltage allowed by MOV: 300 V AC
 (*2) TVS protection voltage: 480 V

Heatsinks (to be used either with SP1P/pad or SP1/grease). Further heatsink options are shown in the following chapter.

Heatsinks	Thermal resistance [°C/W]	Dimensions H x W x D (mm)	Mounting type
HS_003	1.9	106x96x110	DIN rail (with clip)
HS_012	2.1	106x96x50	Panel (with screws)
HS_005	1.6	122x55x59	DIN rail (with clip)

Accessories

Thermal conducting pad	SP1P/pad
Thermal conducting grease	SP1/grease



fig. 1. Wiring diagram

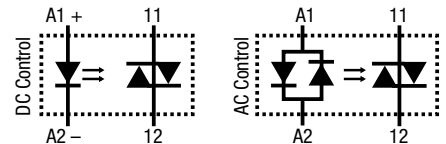


fig. 2. Thermal derating curve 10 A

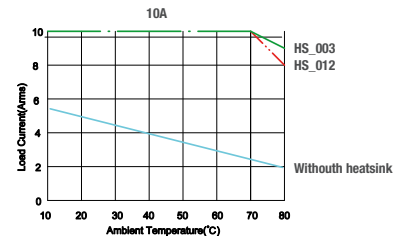


fig. 3. Thermal derating curve 15 A

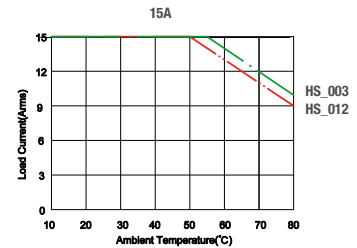


fig. 4. Thermal derating curve 20 A

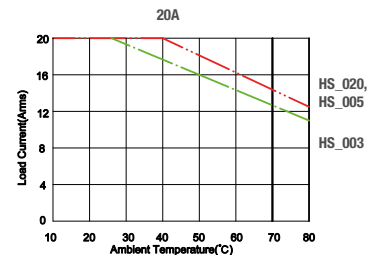
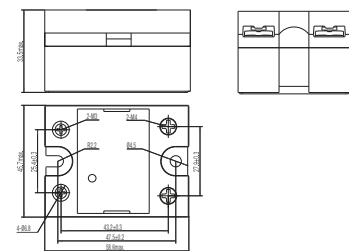


fig. 5. Dimension (mm)



Technical approvals, conformities

Standards EN 60950-1, EN 62314



SP1PXS-TZX0240

1 phase | normally open solid state AC up to 280V, 60A | synchr zero | screw IP 20



Main circuit

Output type	⚡ SCR		
Type	Synchronized zero		
Rated voltage AC	240		
Output voltage range AC	48 ... 280 V		
Operating frequency	47 ... 63 Hz		
Recommended minimum contact load	100 mA		
Maximum leakage current @ rated voltage A	10 mA		
Maximum voltage drop @ rated current	≤ 1.7 V rms		
Repetitive peak voltage in off-state	600 Vpk		
Maximum off state dv / dt	500 V / μs		
Maximum non repetitive di / dt	50 A/μs		
Contact type	Screw		
Contact	1 NO		
Load current	25 A	40 A	60 A
Thermal derating, refer to:	fig. 2.	fig. 3.	fig. 4.
Inrush current @ 10 ms	250 A	500 A	700 A
I ² t @ 10 ms	312 A ² s	1250 A ² s	2450 A ² s

Control circuit

Operating voltage range	4 ... 32 V DC	90 ... 280 V AC
Maximum input current @ maximum operating voltage	25 mA	25 mA
Pick-up voltage	4 V DC	90 V AC
Release voltage	1 V DC	10 V AC
Power consumption DC / AC	0.8 W	7 VA

Insulation

Rated test voltage input/output	4000 Vrms / 1 min
Rated test voltage input output/base	2500 Vrms / 1 min
Overvoltage category	III

General data

Ambient temperature storage (no ice)	-30 ... 100 °C
Ambient temperature operation	-30 ... 80 °C
Pick up time DC control / AC control	1/2 cycle + 1 ms / 30 ms
Release time DC control / AC control	1/2 cycle + 1 ms / 30 ms
Power Factor	> 0.5
Protection degree	IP 20
Dimension	fig. 5.
Weight	120 g
Housing material	PBT

Product reference (o.r. = on request)

Description	Type	A		
		025	040	060
DC Control				
1 NO, Led, RC Protection	SP1PXS-TZX0240N...X/DC4-32V	o.r.	✓	✓
1 NO, Led, MOV and RC protection	SP1PXS-TZX0240V...X/DC4-32V	o.r.	o.r.	o.r.
1 NO, Led, TVS and RC protection	SP1PXS-TZX0240T...X/DC4-32V	o.r.	✓	✓
AC Control				
1 NO, Led, RC Protection	SP1PXS-TZX0240N...X/AC90-280V	✓	✓	✓
1 NO, Led, MOV and RC protection	SP1PXS-TZX0240V...X/AC90-280V	o.r.	o.r.	o.r.
1 NO, Led, TVS and RC protection	SP1PXS-TZX0240T...X/AC90-280V	✓	✓	✓

Complete load current to complete product reference

(*1) Maximum operating voltage allowed by MOV: 300 V AC

(*2) TVS protection voltage: 480 V

Heatsinks (to be used either with SP1P/pad or SP1/grease). Further heatsink options are shown in the following chapter.

Heatsinks	Thermal resistance [°C/W]	Dimensions H x W x D (mm)	Mounting type
HS_005	1.6	122x55x59	DIN rail (with clip)
HS_020	1.6	106x50x96	Panel (with screws)
HS_007	0.8	122.5x81x100.5	DIN rail (with clip)

Accessories

Thermal conducting pad	SP1P/pad
Thermal conducting grease	SP1/grease



fig. 1. Wiring diagram

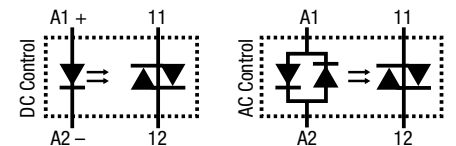


fig. 2. Thermal derating curve 25 A

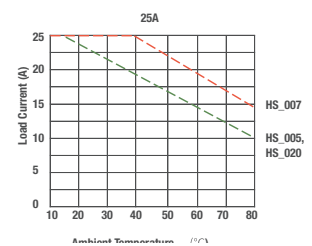


fig. 3. Thermal derating curve 40 A

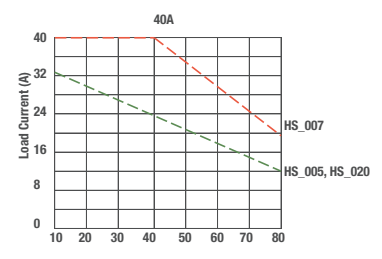


fig. 4. Thermal derating curve 60 A

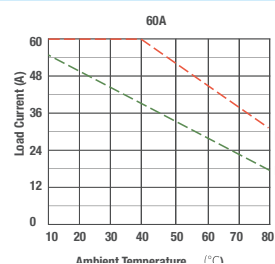
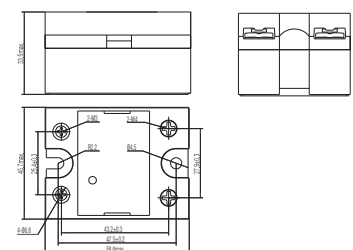


fig. 5. Dimension (mm)



Technical approvals, conformities

Standards EN 60950-1, EN 62314



SP1PXS-TIX0240

1 phase | normally open solid state AC up to 280V, 60A | instantaneous | screw IP 20



Main circuit

Output type	⚡ SCR		
Type	Instantaneous		
Rated voltage AC	240		
Output voltage range AC	48 ... 280 V		
Operating frequency	47 ... 63 Hz		
Recommended minimum contact load	100 mA		
Maximum leakage current @ rated voltage A	10 mA		
Maximum voltage drop @ rated current	≤ 1.7 V rms		
Repetitive peak voltage in off-state	600 Vpk		
Maximum off state dv / dt	500 V / μs		
Maximum non repetitive di / dt	50 A/μs		
Contact type	Screw		
Contact	1 NO		
Load current	25 A	40 A	60 A
Thermal derating, refer to:	fig. 2.	fig. 3.	fig. 4.
Inrush current @ 10 ms	250 A	500 A	700 A
I²t @ 10 ms	312 A²s	1250 A²s	2450 A²s

Control circuit

Operating voltage range	4 ... 32 V DC	90 ... 280 V AC
Maximum input current @ maximum operating voltage	25 mA	25 mA
Pick-up voltage	4 V DC	90 V AC
Release voltage	1 V DC	10 V AC
Power consumption DC / AC	0.8 W	7 VA

Insulation

Rated test voltage input/output	4000 Vrms / 1 min
Rated test voltage input output/base	2500 Vrms / 1 min
Overvoltage category	III

General data

Ambient temperature storage (no ice)	-30 ... 100 °C
Ambient temperature operation	-30 ... 80 °C
Pick up time DC control / AC control	1 ms / 30 ms
Release time DC control / AC control	1/2 cycle + 1 ms / 30 ms
Power Factor	> 0.5
Protection degree	IP 20
Dimension	fig. 5.
Weight	120 g
Housing material	PBT

Product reference (o.r. = on request)

Description	Type	A		
		025	040	060
DC Control				
1 NO, Led, RC Protection	SP1PXS-TIX0240N...X/DC4-32V	o.r.	✓	o.r.
1 NO, Led, MOV and RC protection	SP1PXS-TIX0240V...X/DC4-32V	o.r.	o.r.	o.r.
1 NO, Led, TVS and RC protection	SP1PXS-TIX0240T...X/DC4-32V	o.r.	✓	o.r.
AC Control				
1 NO, Led, RC Protection	SP1PXS-TIX0240N...X/AC90-280V	✓	✓	o.r.
1 NO, Led, MOV and RC protection	SP1PXS-TIX0240V...X/AC90-280V	o.r.	o.r.	o.r.
1 NO, Led, TVS and RC protection	SP1PXS-TIX0240T...X/AC90-280V	✓	✓	o.r.

Complete load current to complete product reference

(*1) Maximum operating voltage allowed by MOV: 300 V AC

(*2) TVS protection voltage: 480 V

Heatsinks (to be used either with SP1P/pad or SP1/grease). Further heatsink options are shown in the following chapter.

Heatsinks	Thermal resistance [°C/W]	Dimensions H x W x D (mm)	Mounting type
HS_005	1.6	122x55x59	DIN rail (with clip)
HS_020	1.6	106x50x96	Panel (with screws)
HS_007	0.8	122.5x81x100.5	DIN rail (with clip)

Accessories

Thermal conducting pad	SP1P/pad
Thermal conducting grease	SP1/grease



fig. 1. Wiring diagram

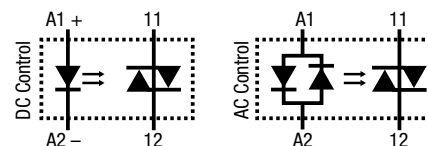


fig. 2. Thermal derating curve 25 A

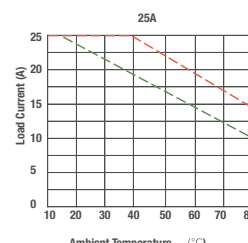


fig. 3. Thermal derating curve 40 A

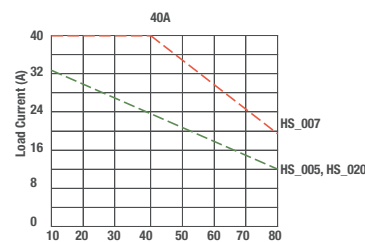


fig. 4. Thermal derating curve 60 A

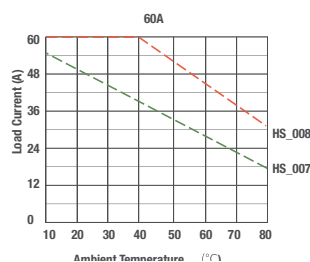
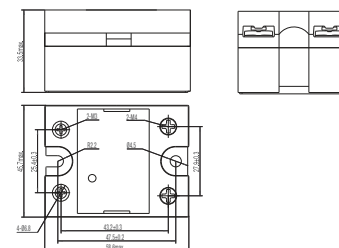


fig. 5. Dimension (mm)



Technical approvals, conformities

Standards EN 60950-1, EN 62314



SP1PXS-TZX0240

1 phase | normally open solid state AC up to 280V, 80A | synchr zero | screw IP 20



Main circuit

Output type	⚡ SCR
Type	Synchronized zero
Rated voltage AC	240
Output voltage range AC	48 ... 280 V
Operating frequency	47 ... 63 Hz
Recommended minimum contact load	100 mA
Maximum leakage current @ rated voltage A	10 mA
Maximum voltage drop @ rated current	≤ 1.7 V rms
Repetitive peak voltage in off-state	600 Vpk
Maximum off state dv / dt	500 V / μs
Maximum non repetitive di / dt	50 A/μs
Contact type	Screw
Contact	1 NO
Load current	80 A
Thermal derating, refer to:	fig. 2.
Inrush current @ 10 ms	1000 A
I²t @ 10 ms	5000 A²s

Control circuit

Operating voltage range	4 ... 32 V DC	90 ... 280 V AC
Maximum input current @ maximum operating voltage	25 mA	25 mA
Pick-up voltage	4 V DC	90 V AC
Release voltage	1 V DC	10 V AC
Power consumption DC / AC	0.8 W	7 VA

Insulation

Rated test voltage input/output	4000 Vrms / 1 min
Rated test voltage input output/base	2500 Vrms / 1 min
Overvoltage category	III

General data

Ambient temperature storage (no ice)	-30 ... 100 °C
Ambient temperature operation	-30 ... 80 °C
Pick up time DC control / AC control	1/2 cycle + 1 ms / 30 ms
Release time DC control / AC control	1/2 cycle + 1 ms / 30 ms
Power Factor	> 0.5
Protection degree	IP 20
Dimension	fig. 3.
Weight	180 g
Housing material	PBT

Product reference (o.r. = on request)

Description	Type	A
DC Control		080
1 NO, Led, RC Protection	SP1PXS-TZX0240N...X/DC4-32V	✓
1 NO, Led, MOV and RC protection	SP1PXS-TZX0240V...X/DC4-32V	o.r.
1 NO, Led, TVS and RC protection	SP1PXS-TZX0240T...X/DC4-32V	✓
AC Control		
1 NO, Led, RC Protection	SP1PXS-TZX0240N...X/AC90-280V	✓
1 NO, Led, MOV and RC protection	SP1PXS-TZX0240V...X/AC90-280V	o.r.
1 NO, Led, TVS and RC protection	SP1PXS-TZX0240T...X/AC90-280V	✓

Complete load current to complete product reference

(*1) Maximum operating voltage allowed by MOV: 300 V AC

(*2) TVS protection voltage: 480 V

Heatsinks (to be used either with SP1P/pad or SP1/grease). Further heatsink options are shown in the following chapter.

Heatsinks	Thermal resistance [°C/W]	Dimensions H x W x D (mm)	Mounting type
HS_006	0.6	148.5x55x59	DIN rail (with clip)
HS_015	0.6	106x80x96	Panel (with screws)
HS_007	0.8	122.5x81x100.5	DIN rail (with clip)

Accessories

Thermal conducting pad	SP1P/pad
Thermal conducting grease	SP1/grease



fig. 1. Wiring diagram

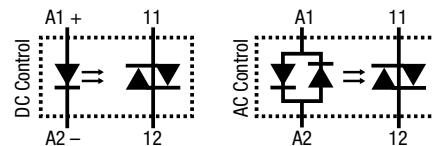


fig. 2. Thermal derating curve 80 A

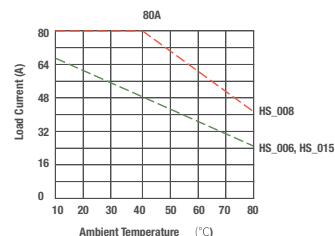
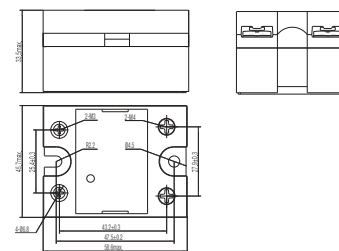


fig. 3. Dimension (mm)



Technical approvals, conformities

Standards EN 60950-1, EN 62314

Approvals

SP1PXS-TIX0240



1 phase | normally open solid state AC up to 280V, 80A | instantaneous | screw IP 20

Main circuit

Output type	SCR
Type	Instantaneous
Rated voltage AC	240
Output voltage range AC	48 ... 280 V
Operating frequency	47 ... 63 Hz
Recommended minimum contact load	100 mA
Maximum leakage current @ rated voltage A	10 mA
Maximum voltage drop @ rated current	≤ 1.7 V rms
Repetitive peak voltage in off-state	600 Vpk
Maximum off state dv / dt	500 V / μs
Maximum non repetitive di / dt	50 A/μs
Contact type	Screw
Contact	1 NO
Load current	80 A
Thermal derating, refer to:	fig. 2.
Inrush current @ 10 ms	1000 A
I ² t @ 10 ms	5000 A ² s



fig. 1. Wiring diagram

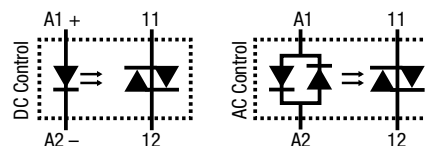


fig. 2. Thermal derating curve 80 A

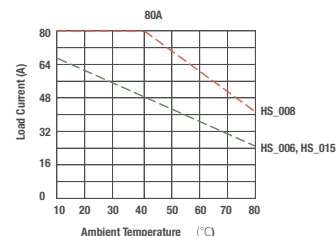
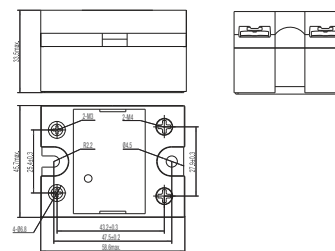


fig. 3. Dimension (mm)



Technical approvals, conformities

Standards EN 60950-1, EN 62314

Approvals

Control circuit

Operating voltage range	4 ... 32 V DC	90 ... 280 V AC
Maximum input current @ maximum operating voltage	25 mA	25 mA
Pick-up voltage	4 V DC	90 V AC
Release voltage	1 V DC	10 V AC
Power consumption DC / AC	0.8 W	7 VA

Insulation

Rated test voltage input/output	4000 Vrms / 1 min
Rated test voltage input output/base	2500 Vrms / 1 min
Overvoltage category	III

General data

Ambient temperature storage (no ice)	-30 ... 100 °C
Ambient temperature operation	-30 ... 80 °C
Pick up time DC control / AC control	1 ms / 30 ms
Release time DC control / AC control	1/2 cycle + 1 ms / 30 ms
Power Factor	> 0.5
Protection degree	IP 20
Dimension	fig. 3.
Weight	180 g
Housing material	PBT

Product reference (o.r. = on request)

Description	Type	A
DC Control		080
1 NO, Led, RC Protection	SP1PXS-TIX0240N...X/DC4-32V	o.r.
1 NO, Led, MOV and RC protection	SP1PXS-TIX0240V...X/DC4-32V	o.r.
1 NO, Led, TVS and RC protection	SP1PXS-TIX0240T...X/DC4-32V	o.r.
AC Control		
1 NO, Led, RC Protection	SP1PXS-TIX0240N...X/AC90-280V	o.r.
1 NO, Led, MOV and RC protection	SP1PXS-TIX0240V...X/AC90-280V	o.r.
1 NO, Led, TVS and RC protection	SP1PXS-TIX0240T...X/AC90-280V	o.r.

Complete load current to complete product reference
 (*1) Maximum operating voltage allowed by MOV: 300 V AC
 (*2) TVS protection voltage: 480 V

Heatsinks (to be used either with SP1P/pad or SP1/grease). Further heatsink options are shown in the following chapter.

Heatsinks	Thermal resistance [°C/W]	Dimensions H x W x D (mm)	Mounting type
HS_006	0.6	148.5x55x59	DIN rail (with clip)
HS_015	0.6	106x80x96	Panel (with screws)
HS_007	0.8	122.5x81x100.5	DIN rail (with clip)

Accessories

Thermal conducting pad	SP1P/pad
Thermal conducting grease	SP1/grease

SP1PXS-TZX0480

1 phase | normally open solid state AC up to 530V, 20A | synchr zero | screw IP 20



Main circuit

Output type	⚡ Triac		
Type	Synchronized zero		
Rated voltage AC	480		
Output voltage range AC	48 ... 530 V		
Operating frequency	47 ... 63 Hz		
Recommended minimum contact load	100 mA		
Maximum leakage current @ rated voltage A	10 mA		
Maximum voltage drop @ rated current	≤ 1.7 V rms		
Repetitive peak voltage in off-state	1200 Vpk		
Maximum off state dv / dt	200 V / μs		
Maximum non repetitive di / dt	50 A/μs		
Contact type	Screw		
Contact	1 NO		
Load current	10 A	15 A	20 A
Thermal derating, refer to:	fig. 2.	fig. 3.	fig. 4.
Inrush current @ 10 ms	120 A	160 A	200 A
I ² t @ 10 ms	72 A ² s	128 A ² s	200 A ² s

Control circuit

Operating voltage range	4 ... 32 V DC	90 ... 280 V AC
Maximum input current @ maximum operating voltage	25 mA	25 mA
Pick-up voltage	4 V DC	90 V AC
Release voltage	1 V DC	10 V AC
Power consumption DC / AC	0.8 W	7 VA

Insulation

Rated test voltage input/output	4000 Vrms / 1 min
Rated test voltage input output/base	2500 Vrms / 1 min
Overvoltage category	III

General data

Ambient temperature storage (no ice)	-30 ... 100 °C
Ambient temperature operation	-30 ... 80 °C
Pick up time DC control / AC control	1/2 cycle + 1 ms / 30 ms
Release time DC control / AC control	1/2 cycle + 1 ms / 30 ms
Power Factor	> 0.5
Protection degree	IP 20
Dimension	fig. 5.
Weight	113 g
Housing material	PBT

Product reference (o.r. = on request)

Description	Type	A		
		010	015	020
DC Control				
1 NO, Led, RC Protection	SP1PXS-TZX0480N...X/DC4-32V	o.r.	o.r.	o.r.
1 NO, Led, MOV and RC protection	SP1PXS-TZX0480V...X/DC4-32V	o.r.	o.r.	o.r.
1 NO, Led, TVS and RC protection	SP1PXS-TZX0480T...X/DC4-32V	o.r.	o.r.	o.r.
AC Control				
1 NO, Led, RC Protection	SP1PXS-TZX0480N...X/AC90-280V	o.r.	o.r.	o.r.
1 NO, Led, MOV and RC protection	SP1PXS-TZX0480V...X/AC90-280V	o.r.	o.r.	o.r.
1 NO, Led, TVS and RC protection	SP1PXS-TZX0480T...X/AC90-280V	o.r.	o.r.	o.r.

Complete load current to complete product reference

(*1) Maximum operating voltage allowed by MOV: 550 V AC

(*2) TVS protection voltage: 960 V

Heatsinks (to be used either with SP1P/pad or SP1/grease). Further heatsink options are shown in the following chapter.

Heatsinks	Thermal resistance [°C/W]	Dimensions H x W x D (mm)	Mounting type
HS_003	1.9	106x96x110	DIN rail (with clip)
HS_012	2.1	106x96x50	Panel (with screws)
HS_005	1.6	122x55x59	DIN rail (with clip)

Accessories

Thermal conducting pad	SP1P/pad
Thermal conducting grease	SP1/grease



fig. 1. Wiring diagram

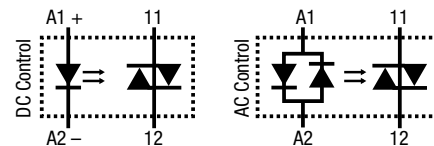


fig. 2. Thermal derating curve 10 A

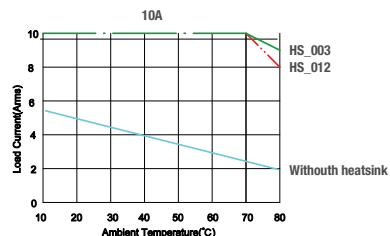


fig. 3. Thermal derating curve 15 A

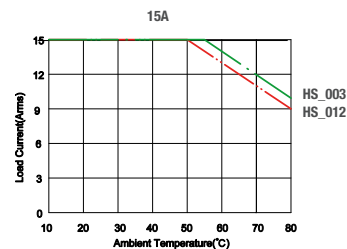


fig. 4. Thermal derating curve 20 A

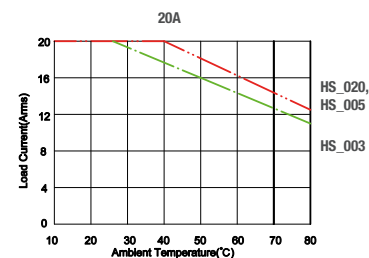
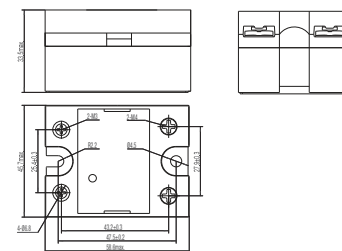


fig. 5. Dimension (mm)



Technical approvals, conformities

Standards EN 60950-1, EN 62314



SP1PXS-TIX0480

1 phase | normally open solid state AC up to 530V, 20A | instantaneous | screw IP 20



Main circuit

Output type	⚡ Triac		
Type	Instantaneous		
Rated voltage AC	480		
Output voltage range AC	48 ... 530 V		
Operating frequency	47 ... 63 Hz		
Recommended minimum contact load	100 mA		
Maximum leakage current @ rated voltage A	10 mA		
Maximum voltage drop @ rated current	≤ 1.7 V rms		
Repetitive peak voltage in off-state	1200 Vpk		
Maximum off state dv / dt	200 V / μs		
Maximum non repetitive di / dt	50 A/μs		
Contact type	Screw		
Contact	1 NO		
Load current	10 A	15 A	20 A
Thermal derating, refer to:	fig. 2.	fig. 3.	fig. 4.
Inrush current @ 10 ms	120 A	160 A	200 A
I²t @ 10 ms	72 A²s	128 A²s	200 A²s

Control circuit

Operating voltage range	4 ... 32 V DC	90 ... 280 V AC
Maximum input current @ maximum operating voltage	25 mA	25 mA
Pick-up voltage	4 V DC	90 V AC
Release voltage	1 V DC	10 V AC
Power consumption DC / AC	0.8 W	7 VA

Insulation

Rated test voltage input/output	4000 Vrms / 1 min
Rated test voltage input output/base	2500 Vrms / 1 min
Overvoltage category	III

General data

Ambient temperature storage (no ice)	-30 ... 100 °C
Ambient temperature operation	-30 ... 80 °C
Pick up time DC control / AC control	1 ms / 30 ms
Release time DC control / AC control	1/2 cycle + 1 ms / 30 ms
Power Factor	> 0.5
Protection degree	IP 20
Dimension	fig. 5.
Weight	113 g
Housing material	PBT

Product reference (o.r. = on request)

Description	Type	A		
		010	015	020
DC Control				
1 NO, Led, RC Protection	SP1PXS-TIX0480N...X/DC4-32V	o.r.	o.r.	o.r.
1 NO, Led, MOV and RC protection	SP1PXS-TIX0480V...X/DC4-32V	o.r.	o.r.	o.r.
1 NO, Led, TVS and RC protection	SP1PXS-TIX0480T...X/DC4-32V	o.r.	o.r.	o.r.
AC Control				
1 NO, Led, RC Protection	SP1PXS-TIX0480N...X/AC90-280V	o.r.	o.r.	o.r.
1 NO, Led, MOV and RC protection	SP1PXS-TIX0480V...X/AC90-280V	o.r.	o.r.	o.r.
1 NO, Led, TVS and RC protection	SP1PXS-TIX0480T...X/AC90-280V	o.r.	o.r.	o.r.

Complete load current to complete product reference

(*1) Maximum operating voltage allowed by MOV: 550 V AC

(*2) TVS protection voltage: 960 V

Heatsinks (to be used either with SP1P/pad or SP1/grease). Further heatsink options are shown in the following chapter.

Heatsinks	Thermal resistance [°C/W]	Dimensions H x W x D (mm)	Mounting type
HS_003	1.9	106x96x110	DIN rail (with clip)
HS_012	2.1	106x96x50	Panel (with screws)
HS_005	1.6	122x55x59	DIN rail (with clip)

Accessories

Thermal conducting pad	SP1P/pad
Thermal conducting grease	SP1/grease



fig. 1. Wiring diagram

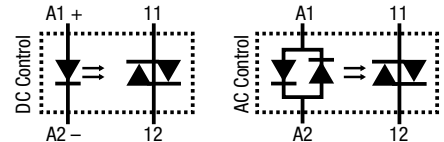


fig. 2. Thermal derating curve 10 A

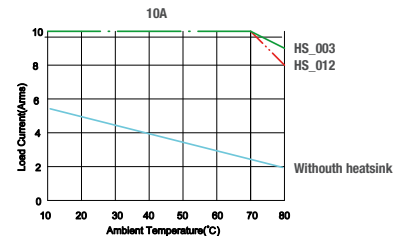


fig. 3. Thermal derating curve 15 A

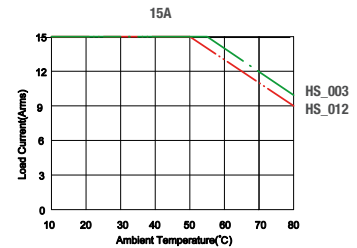


fig. 4. Thermal derating curve 20 A

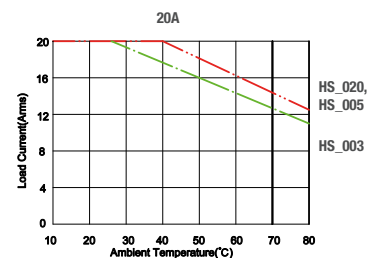
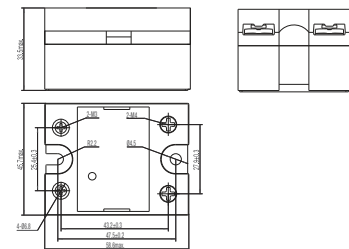


fig. 5. Dimension (mm)



Technical approvals, conformities

Standards EN 60950-1, EN 62314



SP1PXS-TZX0480

1 phase | normally open solid state AC up to 530V, 60A | synchr zero | screw IP 20



Main circuit

Output type	⚡ SCR		
Type	Synchronized zero		
Rated voltage AC	480		
Output voltage range AC	48 ... 530 V		
Operating frequency	47 ... 63 Hz		
Recommended minimum contact load	100 mA		
Maximum leakage current @ rated voltage A	10 mA		
Maximum voltage drop @ rated current	≤ 1.7 V rms		
Repetitive peak voltage in off-state	1200 Vpk		
Maximum off state dv / dt	500 V / μs		
Maximum non repetitive di / dt	50 A/μs		
Contact type	Screw		
Contact	1 NO		
Load current	25 A	40 A	60 A
Thermal derating, refer to:	fig. 2.	fig. 3.	fig. 4.
Inrush current @ 10 ms	250 A	500 A	700 A
I ² t @ 10 ms	312 A ² s	1250 A ² s	2450 A ² s

Control circuit

Operating voltage range	4 ... 32 V DC	90 ... 280 V AC
Maximum input current @ maximum operating voltage	25 mA	25 mA
Pick-up voltage	4 V DC	90 V AC
Release voltage	1 V DC	10 V AC
Power consumption DC / AC	0.8 W	7 VA

Insulation

Rated test voltage input/output	4000 Vrms / 1 min
Rated test voltage input output/base	2500 Vrms / 1 min
Overvoltage category	III

General data

Ambient temperature storage (no ice)	-30 ... 100 °C
Ambient temperature operation	-30 ... 80 °C
Pick up time DC control / AC control	1/2 cycle + 1 ms / 30 ms
Release time DC control / AC control	1/2 cycle + 1 ms / 30 ms
Power Factor	> 0.5
Protection degree	IP 20
Dimension	fig. 5.
Weight	120 g
Housing material	PBT

Product reference (o.r. = on request)

Description	Type	A		
		025	040	060
DC Control				
1 NO, Led, RC Protection	SP1PXS-TZX0480N...X/DC4-32V	o.r.	✓	✓
1 NO, Led, MOV and RC protection	SP1PXS-TZX0480V...X/DC4-32V	o.r.	o.r.	o.r.
1 NO, Led, TVS and RC protection	SP1PXS-TZX0480T...X/DC4-32V	o.r.	✓	✓
AC Control				
1 NO, Led, RC Protection	SP1PXS-TZX0480N...X/AC90-280V	✓	✓	✓
1 NO, Led, MOV and RC protection	SP1PXS-TZX0480V...X/AC90-280V	o.r.	o.r.	o.r.
1 NO, Led, TVS and RC protection	SP1PXS-TZX0480T...X/AC90-280V	✓	✓	✓

Complete load current to complete product reference

(*1) Maximum operating voltage allowed by MOV: 550 V AC

(*2) TVS protection voltage: 960 V

Heatsinks (to be used either with SP1P/pad or SP1/grease). Further heatsink options are shown in the following chapter.

Heatsinks	Thermal resistance [°C/W]	Dimensions H x W x D (mm)	Mounting type
HS_005	1.6	122x55x59	DIN rail (with clip)
HS_020	1.6	106x50x96	Panel (with screws)
HS_007	0.8	122.5x81x100.5	DIN rail (with clip)

Accessories

Thermal conducting pad	SP1P/pad
Thermal conducting grease	SP1/grease



fig. 1. Wiring diagram

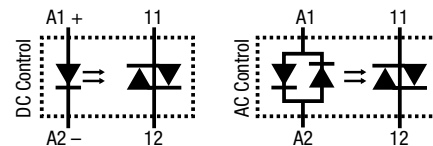


fig. 2. Thermal derating curve 25 A

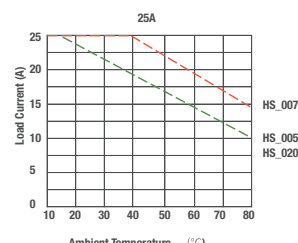


fig. 3. Thermal derating curve 40 A

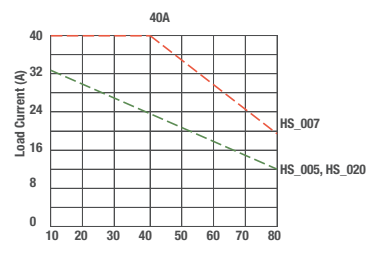


fig. 4. Thermal derating curve 60 A

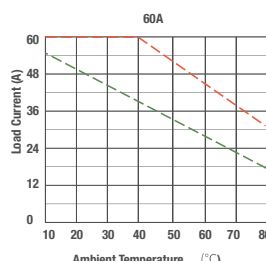
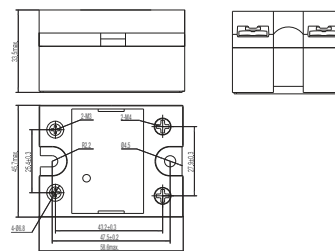


fig. 5. Dimension (mm)



Technical approvals, conformities

Standards EN 60950-1, EN 62314



SP1PXS-TIX0480



1 phase | normally open solid state AC up to 530V, 60A | instantaneous | screw IP 20

Main circuit

Output type	⚡ SCR		
Type	Instantaneous		
Rated voltage AC	480		
Output voltage range AC	48 ... 530 V		
Operating frequency	47 ... 63 Hz		
Recommended minimum contact load	100 mA		
Maximum leakage current @ rated voltage A	10 mA		
Maximum voltage drop @ rated current	≤ 1.7 V rms		
Repetitive peak voltage in off-state	1200 Vpk		
Maximum off state dv / dt	500 V / μs		
Maximum non repetitive di / dt	50 A/μs		
Contact type	Screw		
Contact	1 NO		
Load current	25 A	40 A	60 A
Thermal derating, refer to:	fig. 2.	fig. 3.	fig. 4.
Inrush current @ 10 ms	250 A	500 A	700 A
I ² t @ 10 ms	312 A ² s	1250 A ² s	2450 A ² s

Control circuit

Operating voltage range	4 ... 32 V DC	90 ... 280 V AC
Maximum input current @ maximum operating voltage	25 mA	25 mA
Pick-up voltage	4 V DC	90 V AC
Release voltage	1 V DC	10 V AC
Power consumption DC / AC	0.8 W	7 VA

Insulation

Rated test voltage input/output	4000 Vrms / 1 min
Rated test voltage input output/base	2500 Vrms / 1 min
Overvoltage category	III

General data

Ambient temperature storage (no ice)	-30 ... 100 °C
Ambient temperature operation	-30 ... 80 °C
Pick up time DC control / AC control	1 ms / 30 ms
Release time DC control / AC control	1/2 cycle + 1 ms / 30 ms
Power Factor	> 0.5
Protection degree	IP 20
Dimension	fig. 5.
Weight	120 g
Housing material	PBT

Product reference (o.r. = on request)

Description	Type	A		
		025	040	060
DC Control				
1 NO, Led, RC Protection	SP1PXS-TIX0480N...X/DC4-32V	o.r.	✓	o.r.
1 NO, Led, MOV and RC protection	SP1PXS-TIX0480V...X/DC4-32V	o.r.	o.r.	o.r.
1 NO, Led, TVS and RC protection	SP1PXS-TIX0480T...X/DC4-32V	o.r.	✓	o.r.
AC Control				
1 NO, Led, RC Protection	SP1PXS-TIX0480N...X/AC90-280V	✓	✓	o.r.
1 NO, Led, MOV and RC protection	SP1PXS-TIX0480V...X/AC90-280V	o.r.	o.r.	o.r.
1 NO, Led, TVS and RC protection	SP1PXS-TIX0480T...X/AC90-280V	✓	✓	o.r.

Complete load current to complete product reference
 (*1) Maximum operating voltage allowed by MOV: 550 V AC
 (*2) TVS protection voltage: 960 V

Heatsinks (to be used either with SP1P/pad or SP1/grease). Further heatsink options are shown in the following chapter.

Heatsinks	Thermal resistance [°C/W]	Dimensions H x W x D (mm)	Mounting type
HS_005	1.6	122x55x59	DIN rail (with clip)
HS_020	1.6	106x50x96	Panel (with screws)
HS_007	0.8	122.5x81x100.5	DIN rail (with clip)

Accessories

Thermal conducting pad	SP1P/pad
Thermal conducting grease	SP1/grease



fig. 1. Wiring diagram

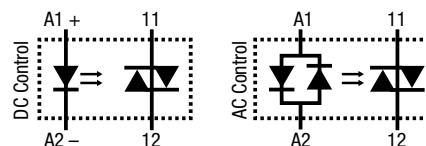


fig. 2. Thermal derating curve 25 A

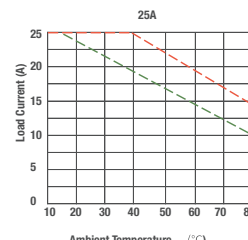


fig. 3. Thermal derating curve 40 A

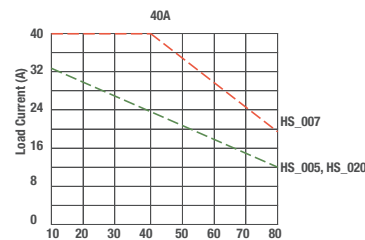


fig. 4. Thermal derating curve 60 A

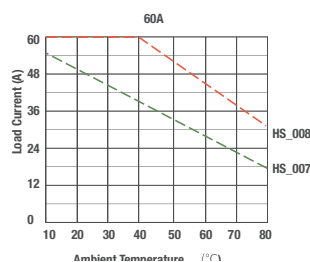
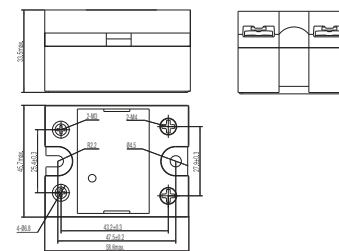


fig. 5. Dimension (mm)



Technical approvals, conformities

Standards EN 60950-1, EN 62314



SP1PXS-TZX0480

1 phase | normally open solid state AC up to 530V, 80A | synchr zero | screw IP 20



Main circuit

Output type	⚡ SCR
Type	Synchronized zero
Rated voltage AC	480
Output voltage range AC	48 ... 530 V
Operating frequency	47 ... 63 Hz
Recommended minimum contact load	100 mA
Maximum leakage current @ rated voltage A	10 mA
Maximum voltage drop @ rated current	≤ 1.7 V rms
Repetitive peak voltage in off-state	1200 Vpk
Maximum off state dv / dt	500 V / μs
Maximum non repetitive di / dt	50 A/μs
Contact type	Screw
Contact	1 NO
Load current	80 A
Thermal derating, refer to:	fig. 2.
Inrush current @ 10 ms	1000 A
I²t @ 10 ms	5000 A²s

Control circuit

Operating voltage range	4 ... 32 V DC	90 ... 280 V AC
Maximum input current @ maximum operating voltage	25 mA	25 mA
Pick-up voltage	4 V DC	90 V AC
Release voltage	1 V DC	10 V AC
Power consumption DC / AC	0.8 W	7 VA

Insulation

Rated test voltage input/output	4000 Vrms / 1 min
Rated test voltage input output/base	2500 Vrms / 1 min
Overvoltage category	III

General data

Ambient temperature storage (no ice)	-30 ... 100 °C
Ambient temperature operation	-30 ... 80 °C
Pick up time DC control / AC control	1/2 cycle + 1 ms / 30 ms
Release time DC control / AC control	1/2 cycle + 1 ms / 30 ms
Power Factor	> 0.5
Protection degree	IP 20
Dimension	fig. 3.
Weight	180 g
Housing material	PBT

Product reference (o.r. = on request)

Product reference (o.r. = on request)		A
Description	Type	080
DC Control		
1 NO, Led, RC Protection	SP1PXS-TZX0480N...X/DC4-32V	✓
1 NO, Led, MOV and RC protection	SP1PXS-TZX0480V...X/DC4-32V	o.r.
1 NO, Led, TVS and RC protection	SP1PXS-TZX0480T...X/DC4-32V	✓
AC Control		
1 NO, Led, RC Protection	SP1PXS-TZX0480N...X/AC90-280V	✓
1 NO, Led, MOV and RC protection	SP1PXS-TZX0480V...X/AC90-280V	o.r.
1 NO, Led, TVS and RC protection	SP1PXS-TZX0480T...X/AC90-280V	✓

Complete load current to complete product reference

(*1) Maximum operating voltage allowed by MOV: 550 V AC

(*2) TVS protection voltage: 960 V

Heatsinks (to be used either with SP1P/pad or SP1/grease). Further heatsink options are shown in the following chapter.

Heatsinks	Thermal resistance [°C/W]	Dimensions H x W x D (mm)	Mounting type
HS_006	0.6	148.5x55x59	DIN rail (with clip)
HS_015	0.6	106x80x96	Panel (with screws)
HS_007	0.8	122.5x81x100.5	DIN rail (with clip)

Accessories

Thermal conducting pad	SP1P/pad
Thermal conducting grease	SP1/grease



fig. 1. Wiring diagram

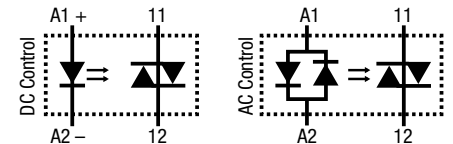


fig. 2. Thermal derating curve 80 A

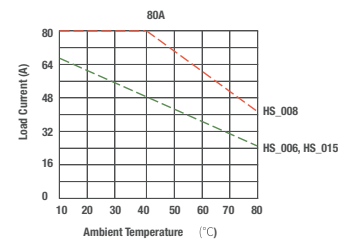
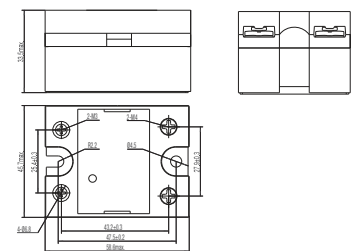


fig. 3. Dimension (mm)



Technical approvals, conformities

Standards EN 60950-1, EN 62314

Approvals

SP1PXS-TIX0480



1 phase | normally open solid state AC up to 530V, 80A | instantaneous | screw IP 20

Main circuit

Output type	SCR
Type	Instantaneous
Rated voltage AC	480
Output voltage range AC	48 ... 530 V
Operating frequency	47 ... 63 Hz
Recommended minimum contact load	100 mA
Maximum leakage current @ rated voltage A	10 mA
Maximum voltage drop @ rated current	≤ 1.7 V rms
Repetitive peak voltage in off-state	1200 Vpk
Maximum off state dv / dt	500 V / μs
Maximum non repetitive di / dt	50 A/μs
Contact type	Screw
Contact	1 NO
Load current	80 A
Thermal derating, refer to:	fig. 2.
Inrush current @ 10 ms	1000 A
I ² t @ 10 ms	5000 A ² s



fig. 1. Wiring diagram

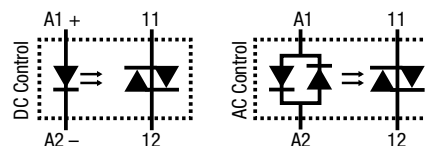


fig. 2. Thermal derating curve 80 A

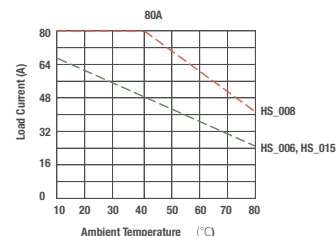
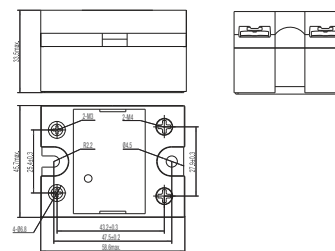


fig. 3. Dimension (mm)



Technical approvals, conformities

Standards EN 60950-1, EN 62314



Control circuit

Operating voltage range	4 ... 32 V DC	90 ... 280 V AC
Maximum input current @ maximum operating voltage	25 mA	25 mA
Pick-up voltage	4 V DC	90 V AC
Release voltage	1 V DC	10 V AC
Power consumption DC / AC	0.8 W	7 VA

Insulation

Rated test voltage input/output	4000 Vrms / 1 min
Rated test voltage input output/base	2500 Vrms / 1 min
Overvoltage category	III

General data

Ambient temperature storage (no ice)	-30 ... 100 °C
Ambient temperature operation	-30 ... 80 °C
Pick up time DC control / AC control	1 ms / 30 ms
Release time DC control / AC control	1/2 cycle + 1 ms / 30 ms
Power Factor	> 0.5
Protection degree	IP 20
Dimension	fig. 3.
Weight	180 g
Housing material	PBT

Product reference (o.r. = on request)

Description	Type	A
DC Control		080
1 NO, Led, RC Protection	SP1PXS-TIX0480N...X/DC4-32V	o.r.
1 NO, Led, MOV and RC protection	SP1PXS-TIX0480V...X/DC4-32V	o.r.
1 NO, Led, TVS and RC protection	SP1PXS-TIX0480T...X/DC4-32V	o.r.
AC Control		
1 NO, Led, RC Protection	SP1PXS-TIX0480N...X/AC90-280V	o.r.
1 NO, Led, MOV and RC protection	SP1PXS-TIX0480V...X/AC90-280V	o.r.
1 NO, Led, TVS and RC protection	SP1PXS-TIX0480T...X/AC90-280V	o.r.

Complete load current to complete product reference
 (*1) Maximum operating voltage allowed by MOV: 550 V AC
 (*2) TVS protection voltage: 960 V

Heatsinks (to be used either with SP1P/pad or SP1/grease). Further heatsink options are shown in the following chapter.

Heatsinks	Thermal resistance [°C/W]	Dimensions H x W x D (mm)	Mounting type
HS_006	0.6	148.5x55x59	DIN rail (with clip)
HS_015	0.6	106x80x96	Panel (with screws)
HS_007	0.8	122.5x81x100.5	DIN rail (with clip)

Accessories

Thermal conducting pad	SP1P/pad
Thermal conducting grease	SP1/grease

SP1PXS-TZX0600

1 phase | normally open solid state AC up to 660V, 20A | synchr zero | screw IP 20



Main circuit

Output type	⚡ Triac		
Type	Synchronized zero		
Rated voltage AC	600		
Output voltage range AC	48 ... 660 V		
Operating frequency	47 ... 63 Hz		
Recommended minimum contact load	100 mA		
Maximum leakage current @ rated voltage A	10 mA		
Maximum voltage drop @ rated current	≤ 1.7 V rms		
Repetitive peak voltage in off-state	1600 Vpk		
Maximum off state dv / dt	200 V / μs		
Maximum non repetitive di / dt	50 A/μs		
Contact type	Screw		
Contact	1 NO		
Load current	10 A	15 A	20 A
Thermal derating, refer to:	fig. 2.	fig. 3.	fig. 4.
Inrush current @ 10 ms	120 A	160 A	200 A
I ² t @ 10 ms	72 A ² s	128 A ² s	200 A ² s

Control circuit

Operating voltage range	4 ... 32 V DC	90 ... 280 V AC
Maximum input current @ maximum operating voltage	25 mA	25 mA
Pick-up voltage	4 V DC	90 V AC
Release voltage	1 V DC	10 V AC
Power consumption DC / AC	0.8 W	7 VA

Insulation

Rated test voltage input/output	4000 Vrms / 1 min
Rated test voltage input output/base	2500 Vrms / 1 min
Overvoltage category	III

General data

Ambient temperature storage (no ice)	-30 ... 100 °C
Ambient temperature operation	-30 ... 80 °C
Pick up time DC control / AC control	1/2 cycle + 1 ms / 30 ms
Release time DC control / AC control	1/2 cycle + 1 ms / 30 ms
Power Factor	> 0.5
Protection degree	IP 20
Dimension	fig. 5.
Weight	113 g
Housing material	PBT

Product reference (o.r. = on request)

Description	Type	A		
		010	015	020
DC Control				
1 NO, Led, RC Protection	SP1PXS-TZX0600N...X/DC4-32V	o.r.	o.r.	o.r.
1 NO, Led, MOV and RC protection	SP1PXS-TZX0600V...X/DC4-32V	o.r.	o.r.	o.r.
1 NO, Led, TVS and RC protection	SP1PXS-TZX0600T...X/DC4-32V	o.r.	o.r.	o.r.
AC Control				
1 NO, Led, RC Protection	SP1PXS-TZX0600N...X/AC90-280V	o.r.	o.r.	o.r.
1 NO, Led, MOV and RC protection	SP1PXS-TZX0600V...X/AC90-280V	o.r.	o.r.	o.r.
1 NO, Led, TVS and RC protection	SP1PXS-TZX0600T...X/AC90-280V	o.r.	o.r.	o.r.

Complete load current to complete product reference

(*1) Maximum operating voltage allowed by MOV: 680 V AC

(*2) TVS protection voltage: 1100 V

Heatsinks (to be used either with SP1P/pad or SP1/grease). Further heatsink options are shown in the following chapter.

Heatsinks	Thermal resistance [°C/W]	Dimensions H x W x D (mm)	Mounting type
HS_003	1.9	106x96x110	DIN rail (with clip)
HS_012	2.1	106x96x50	Panel (with screws)
HS_005	1.6	122x55x59	DIN rail (with clip)

Accessories

Thermal conducting pad	SP1P/pad
Thermal conducting grease	SP1/grease



fig. 1. Wiring diagram

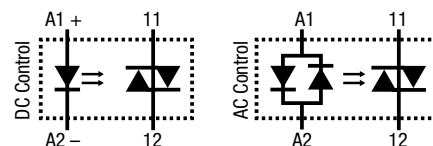


fig. 2. Thermal derating curve 10 A

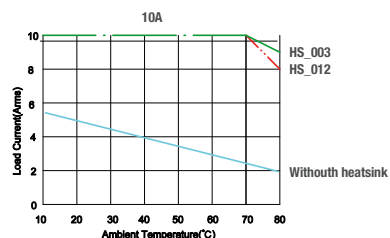


fig. 3. Thermal derating curve 15 A

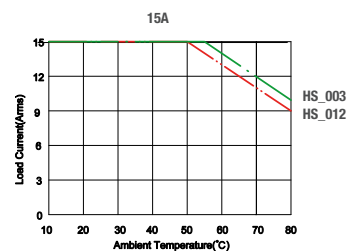


fig. 4. Thermal derating curve 20 A

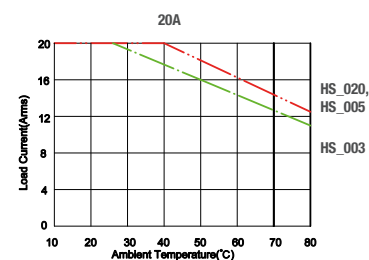
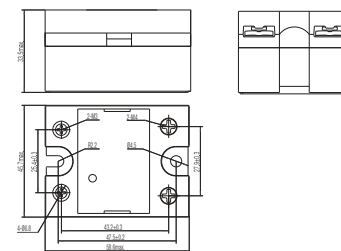


fig. 5. Dimension (mm)



Technical approvals, conformities

Standards EN 60950-1, EN 62314



SP1PXS-TIX0600



1 phase | normally open solid state AC up to 660V, 20A | instantaneous | screw IP 20

Main circuit

Output type	⚡ Triac		
Type	Instantaneous		
Rated voltage AC	600		
Output voltage range AC	48 ... 660 V		
Operating frequency	47 ... 63 Hz		
Recommended minimum contact load	100 mA		
Maximum leakage current @ rated voltage A	10 mA		
Maximum voltage drop @ rated current	≤ 1.7 V rms		
Repetitive peak voltage in off-state	1600 Vpk		
Maximum off state dv / dt	200 V / μs		
Maximum non repetitive di / dt	50 A/μs		
Contact type	Screw		
Contact	1 NO		
Load current	10 A	15 A	20 A
Thermal derating, refer to:	fig. 2.	fig. 3.	fig. 4.
Inrush current @ 10 ms	120 A	160 A	200 A
I²t @ 10 ms	72 A²s	128 A²s	200 A²s

Control circuit

Operating voltage range	4 ... 32 V DC	90 ... 280 V AC
Maximum input current @ maximum operating voltage	25 mA	25 mA
Pick-up voltage	4 V DC	90 V AC
Release voltage	1 V DC	10 V AC
Power consumption DC / AC	0.8 W	7 VA

Insulation

Rated test voltage input/output	4000 Vrms / 1 min
Rated test voltage input output/base	2500 Vrms / 1 min
Overvoltage category	III

General data

Ambient temperature storage (no ice)	-30 ... 100 °C
Ambient temperature operation	-30 ... 80 °C
Pick up time DC control / AC control	1 ms / 30 ms
Release time DC control / AC control	1/2 cycle + 1 ms / 30 ms
Power Factor	> 0.5
Protection degree	IP 20
Dimension	fig. 5.
Weight	113 g
Housing material	PBT

Product reference (o.r. = on request)

Description	Type	A		
		010	015	020
DC Control				
1 NO, Led, RC Protection	SP1PXS-TIX0600N...X/DC4-32V	o.r.	o.r.	o.r.
1 NO, Led, MOV and RC protection	SP1PXS-TIX0600V...X/DC4-32V	o.r.	o.r.	o.r.
1 NO, Led, TVS and RC protection	SP1PXS-TIX0600T...X/DC4-32V	o.r.	o.r.	o.r.
AC Control				
1 NO, Led, RC Protection	SP1PXS-TIX0600N...X/AC90-280V	o.r.	o.r.	o.r.
1 NO, Led, MOV and RC protection	SP1PXS-TIX0600V...X/AC90-280V	o.r.	o.r.	o.r.
1 NO, Led, TVS and RC protection	SP1PXS-TIX0600T...X/AC90-280V	o.r.	o.r.	o.r.

Complete load current to complete product reference
 (*1) Maximum operating voltage allowed by MOV: 680 V AC
 (*2) TVS protection voltage: 1100 V

Heatsinks (to be used either with SP1P/pad or SP1/grease). Further heatsink options are shown in the following chapter.

Heatsinks	Thermal resistance [°C/W]	Dimensions H x W x D (mm)	Mounting type
HS_003	1.9	106x96x110	DIN rail (with clip)
HS_012	2.1	106x96x50	Panel (with screws)
HS_005	1.6	122x55x59	DIN rail (with clip)

Accessories

Thermal conducting pad	SP1P/pad
Thermal conducting grease	SP1/grease



fig. 1. Wiring diagram

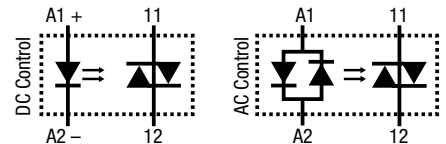


fig. 2. Thermal derating curve 10 A

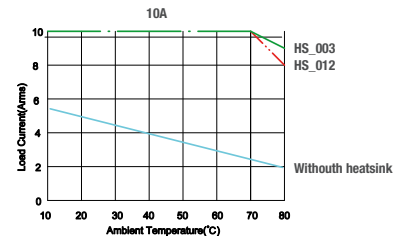


fig. 3. Thermal derating curve 15 A

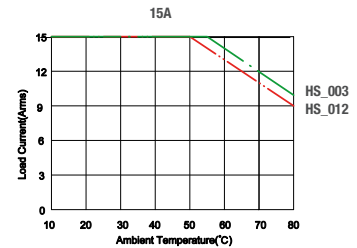


fig. 4. Thermal derating curve 20 A

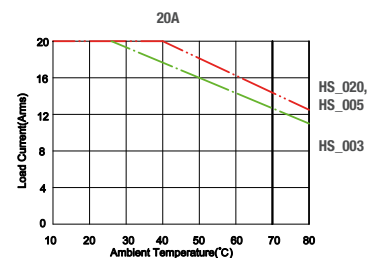
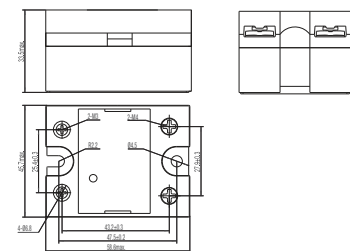


fig. 5. Dimension (mm)



Technical approvals, conformities

Standards EN 60950-1, EN 62314



SP1PXS-TZX0600

1 phase | normally open solid state AC up to 660V, 60A | synchr zero | screw IP 20



Main circuit

Output type	⚡ SCR		
Type	Synchronized zero		
Rated voltage AC	600		
Output voltage range AC	48 ... 660 V		
Operating frequency	47 ... 63 Hz		
Recommended minimum contact load	100 mA		
Maximum leakage current @ rated voltage A	10 mA		
Maximum voltage drop @ rated current	≤ 1.7 V rms		
Repetitive peak voltage in off-state	1600 Vpk		
Maximum off state dv / dt	500 V / μs		
Maximum non repetitive di / dt	50 A/μs		
Contact type	Screw		
Contact	1 NO		
Load current	25 A	40 A	60 A
Thermal derating, refer to:	fig. 2.	fig. 3.	fig. 4.
Inrush current @ 10 ms	250 A	500 A	700 A
I ² t @ 10 ms	312 A ² s	1250 A ² s	2450 A ² s

Control circuit

Operating voltage range	4 ... 32 V DC	90 ... 280 V AC
Maximum input current @ maximum operating voltage	25 mA	25 mA
Pick-up voltage	4 V DC	90 V AC
Release voltage	1 V DC	10 V AC
Power consumption DC / AC	0.8 W	7 VA

Insulation

Rated test voltage input/output	4000 Vrms / 1 min
Rated test voltage input output/base	2500 Vrms / 1 min
Overvoltage category	III

General data

Ambient temperature storage (no ice)	-30 ... 100 °C
Ambient temperature operation	-30 ... 80 °C
Pick up time DC control / AC control	1/2 cycle + 1 ms / 30 ms
Release time DC control / AC control	1/2 cycle + 1 ms / 30 ms
Power Factor	> 0.5
Protection degree	IP 20
Dimension	fig. 5.
Weight	120 g
Housing material	PBT

Product reference (o.r. = on request)

Description	Type	A		
		025	040	060
DC Control				
1 NO, Led, RC Protection	SP1PXS-TZX0600N...X/DC4-32V	o.r.	✓	✓
1 NO, Led, MOV and RC protection	SP1PXS-TZX0600V...X/DC4-32V	o.r.	o.r.	o.r.
1 NO, Led, TVS and RC protection	SP1PXS-TZX0600T...X/DC4-32V	o.r.	✓	✓
AC Control				
1 NO, Led, RC Protection	SP1PXS-TZX0600N...X/AC90-280V	✓	✓	✓
1 NO, Led, MOV and RC protection	SP1PXS-TZX0600V...X/AC90-280V	o.r.	o.r.	o.r.
1 NO, Led, TVS and RC protection	SP1PXS-TZX0600T...X/AC90-280V	✓	✓	✓

Complete load current to complete product reference

(*1) Maximum operating voltage allowed by MOV: 680 V AC

(*2) TVS protection voltage: 1100 V

Heatsinks (to be used either with SP1P/pad or SP1/grease). Further heatsink options are shown in the following chapter.

Heatsinks	Thermal resistance [°C/W]	Dimensions H x W x D (mm)	Mounting type
HS_005	1.6	122x55x59	DIN rail (with clip)
HS_020	1.6	106x50x96	Panel (with screws)
HS_007	0.8	122.5x81x100.5	DIN rail (with clip)

Accessories

Thermal conducting pad	SP1P/pad
Thermal conducting grease	SP1/grease



fig. 1. Wiring diagram

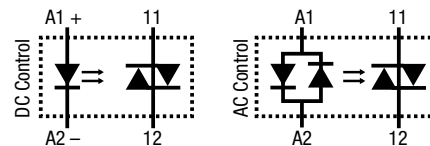


fig. 2. Thermal derating curve 25 A

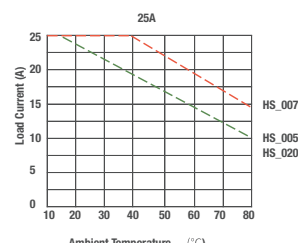


fig. 3. Thermal derating curve 40 A

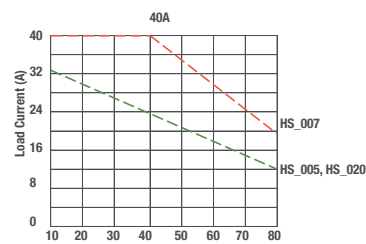


fig. 4. Thermal derating curve 60 A

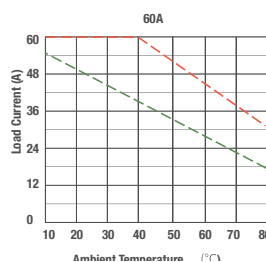
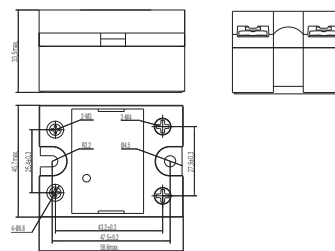


fig. 5. Dimension (mm)



Technical approvals, conformities

Standards EN 60950-1, EN 62314



SP1PXS-TIX0600



1 phase | normally open solid state AC up to 660V, 60A | instantaneous | screw IP 20

Main circuit

Output type	⚡ SCR		
Type	Instantaneous		
Rated voltage AC	600		
Output voltage range AC	48 ... 660 V		
Operating frequency	47 ... 63 Hz		
Recommended minimum contact load	100 mA		
Maximum leakage current @ rated voltage A	10 mA		
Maximum voltage drop @ rated current	≤ 1.7 V rms		
Repetitive peak voltage in off-state	1600 Vpk		
Maximum off state dv / dt	500 V / μs		
Maximum non repetitive di / dt	50 A/μs		
Contact type	Screw		
Contact	1 NO		
Load current	25 A	40 A	60 A
Thermal derating, refer to:	fig. 2.	fig. 3.	fig. 4.
Inrush current @ 10 ms	250 A	500 A	700 A
I²t @ 10 ms	312 A²s	1250 A²s	2450 A²s

Control circuit

Operating voltage range	4 ... 32 V DC	90 ... 280 V AC
Maximum input current @ maximum operating voltage	25 mA	25 mA
Pick-up voltage	4 V DC	90 V AC
Release voltage	1 V DC	10 V AC
Power consumption DC / AC	0.8 W	7 VA

Insulation

Rated test voltage input/output	4000 Vrms / 1 min
Rated test voltage input output/base	2500 Vrms / 1 min
Overvoltage category	III

General data

Ambient temperature storage (no ice)	-30 ... 100 °C
Ambient temperature operation	-30 ... 80 °C
Pick up time DC control / AC control	1 ms / 30 ms
Release time DC control / AC control	1/2 cycle + 1 ms / 30 ms
Power Factor	> 0.5
Protection degree	IP 20
Dimension	fig. 5.
Weight	120 g
Housing material	PBT

Product reference (o.r. = on request)

Description	Type	A		
		025	040	060
DC Control				
1 NO, Led, RC Protection	SP1PXS-TIX0600N...X/DC4-32V	o.r.	✓	o.r.
1 NO, Led, MOV and RC protection	SP1PXS-TIX0600V...X/DC4-32V	o.r.	o.r.	o.r.
1 NO, Led, TVS and RC protection	SP1PXS-TIX0600T...X/DC4-32V	o.r.	✓	o.r.
AC Control				
1 NO, Led, RC Protection	SP1PXS-TIX0600N...X/AC90-280V	✓	✓	o.r.
1 NO, Led, MOV and RC protection	SP1PXS-TIX0600V...X/AC90-280V	o.r.	o.r.	o.r.
1 NO, Led, TVS and RC protection	SP1PXS-TIX0600T...X/AC90-280V	✓	✓	o.r.

Complete load current to complete product reference

(*1) Maximum operating voltage allowed by MOV: 680 V AC

(*2) TVS protection voltage: 1100 V

Heatsinks (to be used either with SP1P/pad or SP1/grease). Further heatsink options are shown in the following chapter.

Heatsinks	Thermal resistance [°C/W]	Dimensions H x W x D (mm)	Mounting type
HS_005	1.6	122x55x59	DIN rail (with clip)
HS_020	1.6	106x50x96	Panel (with screws)
HS_007	0.8	122.5x81x100.5	DIN rail (with clip)

Accessories

Thermal conducting pad	SP1P/pad
Thermal conducting grease	SP1/grease



fig. 1. Wiring diagram

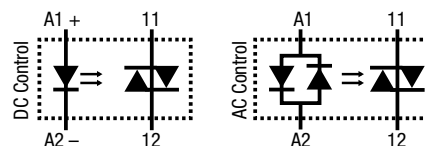


fig. 2. Thermal derating curve 25 A

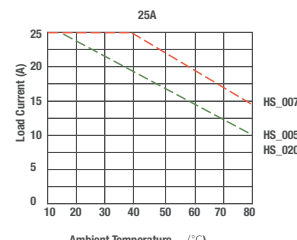


fig. 3. Thermal derating curve 40 A

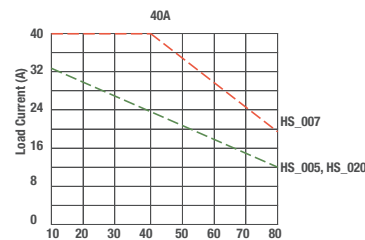


fig. 4. Thermal derating curve 60 A

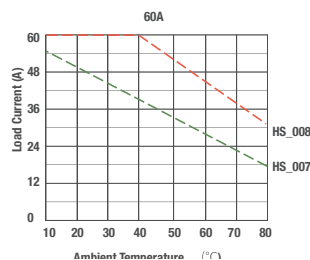
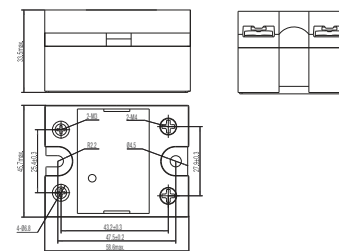


fig. 5. Dimension (mm)



Technical approvals, conformities

Standards EN 60950-1, EN 62314



SP1PXS-TZX0600

1 phase | normally open solid state AC up to 660V, 80A | synchr zero | screw IP 20



Main circuit

Output type	⚡ SCR
Type	Synchronized zero
Rated voltage AC	600
Output voltage range AC	48 ... 660 V
Operating frequency	47 ... 63 Hz
Recommended minimum contact load	100 mA
Maximum leakage current @ rated voltage A	10 mA
Maximum voltage drop @ rated current	≤ 1.7 V rms
Repetitive peak voltage in off-state	1600 Vpk
Maximum off state dv / dt	500 V / μs
Maximum non repetitive di / dt	50 A/μs
Contact type	Screw
Contact	1 NO
Load current	80 A
Thermal derating, refer to:	fig. 2.
Inrush current @ 10 ms	1000 A
I²t @ 10 ms	5000 A²s

Control circuit

Operating voltage range	4 ... 32 V DC	90 ... 280 V AC
Maximum input current @ maximum operating voltage	25 mA	25 mA
Pick-up voltage	4 V DC	90 V AC
Release voltage	1 V DC	10 V AC
Power consumption DC / AC	0.8 W	7 VA

Insulation

Rated test voltage input/output	4000 Vrms / 1 min
Rated test voltage input output/base	2500 Vrms / 1 min
Overvoltage category	III

General data

Ambient temperature storage (no ice)	-30 ... 100 °C
Ambient temperature operation	-30 ... 80 °C
Pick up time DC control / AC control	1/2 cycle + 1 ms / 30 ms
Release time DC control / AC control	1/2 cycle + 1 ms / 30 ms
Power Factor	> 0.5
Protection degree	IP 20
Dimension	fig. 3.
Weight	180 g
Housing material	PBT

Product reference (o.r. = on request)

Product reference (o.r. = on request)		A
Description	Type	080
DC Control		
1 NO, Led, RC Protection	SP1PXS-TZX0600N...X/DC4-32V	✓
1 NO, Led, MOV and RC protection	SP1PXS-TZX0600V...X/DC4-32V	o.r.
1 NO, Led, TVS and RC protection	SP1PXS-TZX0600T...X/DC4-32V	✓
AC Control		
1 NO, Led, RC Protection	SP1PXS-TZX0600N...X/AC90-280V	✓
1 NO, Led, MOV and RC protection	SP1PXS-TZX0600V...X/AC90-280V	o.r.
1 NO, Led, TVS and RC protection	SP1PXS-TZX0600T...X/AC90-280V	✓

Complete load current to complete product reference

(*1) Maximum operating voltage allowed by MOV: 680 V AC

(*2) TVS protection voltage: 1100 V

Heatsinks (to be used either with SP1P/pad or SP1/grease). Further heatsink options are shown in the following chapter.

Heatsinks	Thermal resistance [°C/W]	Dimensions H x W x D (mm)	Mounting type
HS_006	0.6	148.5x55x59	DIN rail (with clip)
HS_015	0.6	106x80x96	Panel (with screws)
HS_007	0.8	122.5x81x100.5	DIN rail (with clip)

Accessories

Thermal conducting pad	SP1P/pad
Thermal conducting grease	SP1/grease



fig. 1. Wiring diagram

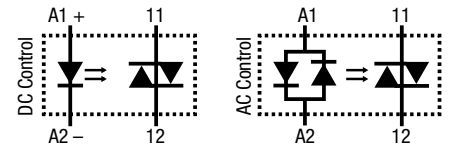


fig. 2. Thermal derating curve 80 A

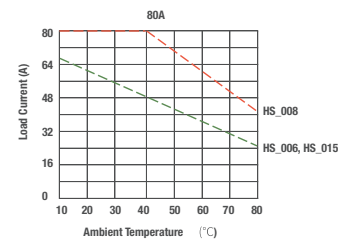
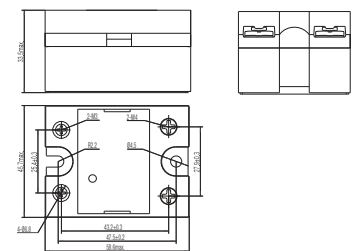


fig. 3. Dimension (mm)



Technical approvals, conformities

Standards EN 60950-1, EN 62314

Approvals

SP1PXS-TIX0600



1 phase | normally open solid state AC up to 660V, 80A | instantaneous | screw IP 20

Main circuit

Output type	SCR
Type	Instantaneous
Rated voltage AC	600
Output voltage range AC	48 ... 660 V
Operating frequency	47 ... 63 Hz
Recommended minimum contact load	100 mA
Maximum leakage current @ rated voltage A	10 mA
Maximum voltage drop @ rated current	≤ 1.7 V rms
Repetitive peak voltage in off-state	1600 Vpk
Maximum off state dv / dt	500 V / μs
Maximum non repetitive di / dt	50 A/μs
Contact type	Screw
Contact	1 NO
Load current	80 A
Thermal derating, refer to:	fig. 2.
Inrush current @ 10 ms	1000 A
I ² t @ 10 ms	5000 A ² s



fig. 1. Wiring diagram

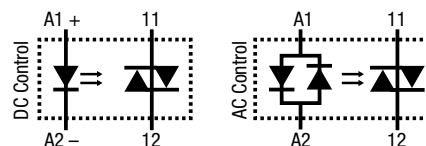


fig. 2. Thermal derating curve 80 A

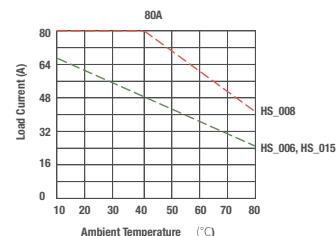
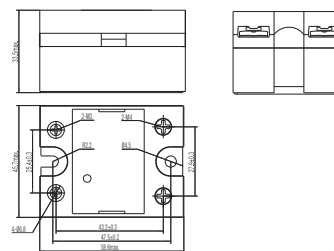


fig. 3. Dimension (mm)



Technical approvals, conformities

Standards EN 60950-1, EN 62314

Approvals

Control circuit

Operating voltage range	4 ... 32 V DC	90 ... 280 V AC
Maximum input current @ maximum operating voltage	25 mA	25 mA
Pick-up voltage	4 V DC	90 V AC
Release voltage	1 V DC	10 V AC
Power consumption DC / AC	0.8 W	7 VA

Insulation

Rated test voltage input/output	4000 Vrms / 1 min
Rated test voltage input output/base	2500 Vrms / 1 min
Overvoltage category	III

General data

Ambient temperature storage (no ice)	-30 ... 100 °C
Ambient temperature operation	-30 ... 80 °C
Pick up time DC control / AC control	1 ms / 30 ms
Release time DC control / AC control	1/2 cycle + 1 ms / 30 ms
Power Factor	> 0.5
Protection degree	IP 20
Dimension	fig. 3.
Weight	180 g
Housing material	PBT

Product reference (o.r. = on request)

Description	Type	A
DC Control		080
1 NO, Led, RC Protection	SP1PXS-TIX0600N...X/DC4-32V	o.r.
1 NO, Led, MOV and RC protection	SP1PXS-TIX0600V...X/DC4-32V	o.r.
1 NO, Led, TVS and RC protection	SP1PXS-TIX0600T...X/DC4-32V	o.r.
AC Control		
1 NO, Led, RC Protection	SP1PXS-TIX0600N...X/AC90-280V	o.r.
1 NO, Led, MOV and RC protection	SP1PXS-TIX0600V...X/AC90-280V	o.r.
1 NO, Led, TVS and RC protection	SP1PXS-TIX0600T...X/AC90-280V	o.r.

Complete load current to complete product reference
 (*1) Maximum operating voltage allowed by MOV: 680 V AC
 (*2) TVS protection voltage: 1100 V

Heatsinks (to be used either with SP1P/pad or SP1/grease). Further heatsink options are shown in the following chapter.

Heatsinks	Thermal resistance [°C/W]	Dimensions H x W x D (mm)	Mounting type
HS_006	0.6	148.5x55x59	DIN rail (with clip)
HS_015	0.6	106x80x96	Panel (with screws)
HS_007	0.8	122.5x81x100.5	DIN rail (with clip)

Accessories

Thermal conducting pad	SP1P/pad
Thermal conducting grease	SP1/grease

3.4 SSR / Accessories

	Type	Page
Heatsinks (DIN rail mounted with clip)	HS_003 / HS_004 / HS_005 / HS_006 / HS_007 / HS_008	80
Heatsinks (panel mounted with screws)	HS_010 / HS_012	81
Heatsinks (panel mounted with screws)	HS_015 / HS_020 / HS_22 / HS_25	82
Thermal conducting pad	SP1M/pad / SP1P/pad	83
Thermal conducting grease	SP1/grease	83
Transparent cover	SP1MXN/cover	83
Transparent cover	SP1PXN/cover	84

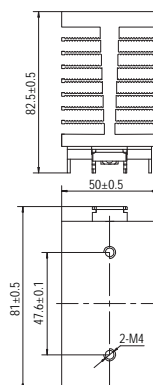
HS_003

General data

Thermal Resistance [°C/W]	1.9
Dimensions H x W x D [mm]	81 x 50 x 82.5
Weight [gr]	328
Mounting type	Din rail (with clip)
Suitable for solid state relays type	SP1M, SP1P
Cooling	Air, natural convection

Product reference

Description	Type	available
Heatsinks (DIN rail mounted with clip)	HS_003	✓



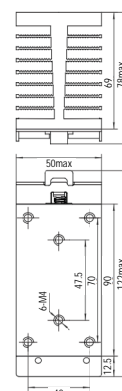
HS_004

General data

Thermal Resistance [°C/W]	1.7
Dimensions H x W x D [mm]	122 x 50 x 78
Weight [gr]	422
Mounting type	Din rail (with clip)
Suitable for solid state relays type	SP1P
Cooling	Air, natural convection

Product reference

Description	Type	available
Heatsinks (DIN rail mounted with clip)	HS_004	✓



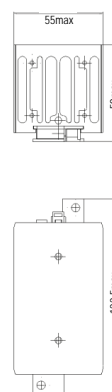
HS_005

General data

Thermal Resistance [°C/W]	1.6
Dimensions H x W x D [mm]	122 x 55 x 59
Weight [gr]	347
Mounting type	Din rail (with clip)
Suitable for solid state relays type	SP1P
Cooling	Air, natural convection

Product reference

Description	Type	available
Heatsinks (DIN rail mounted with clip)	HS_005	✓



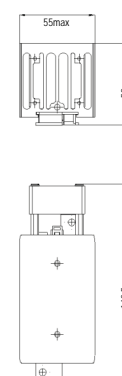
HS_006

General data

Thermal Resistance [°C/W]	0.6
Dimensions H x W x D [mm]	148.5 x 55 x 59
Weight [gr]	397
Mounting type	Din rail (with clip)
Suitable for solid state relays type	SP1P
Cooling	Air, forced convection (fan) Fan voltage 230 V AC

Product reference

Description	Type	available
Heatsinks (DIN rail mounted with clip)	HS_006	✓



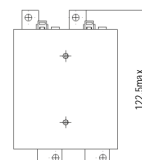
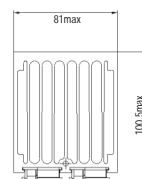
HS_007

General data

Thermal Resistance [°C/W]	0.8
Dimensions H x W x D [mm]	122.5 x 81 x 100.5
Weight [gr]	714
Mounting type	Din rail (with clip)
Suitable for solid state relays type	SP1P
Cooling	Air, natural convection

Product reference

Description	Type	available
Heatsinks (DIN rail mounted with clip)	HS_007	✓



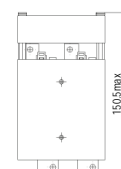
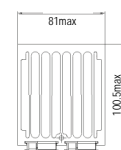
HS_008

General data

Thermal Resistance [°C/W]	0.35
Dimensions H x W x D [mm]	150.5 x 81 x 100.5
Weight [gr]	817
Mounting type	Din rail (with clip)
Suitable for solid state relays type	SP1P
Cooling	Air, forced convection (fan) Fan voltage 230 V AC

Product reference

Description	Type	available
Heatsinks (DIN rail mounted with clip)	HS_008	✓



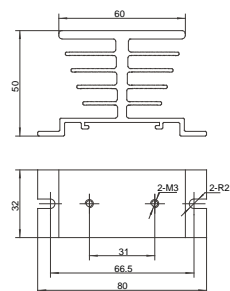
HS_010

General data

Thermal Resistance [°C/W]	2.8
Dimensions H x W x D [mm]	80 x 32 x 50
Weight [gr]	70
Mounting type	Panel (with screws, not incl. in the delivery)
Suitable for solid state relays type	SP1M
Cooling	Air, natural convection

Product reference

Description	Type	available
Heatsinks (panel mounted with screws)	HS_010	✓



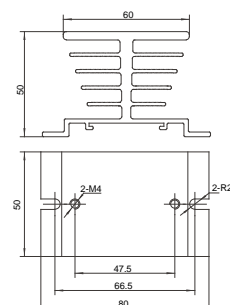
HS_012

General data

Thermal Resistance [°C/W]	2.1
Dimensions H x W x D [mm]	80 x 50 x 50
Weight [gr]	115
Mounting type	Panel (with screws, not incl. in the delivery)
Suitable for solid state relays type	SP1M, SP1P
Cooling	Air, natural convection

Product reference

Description	Type	available
Heatsinks (panel mounted with screws)	HS_012	✓



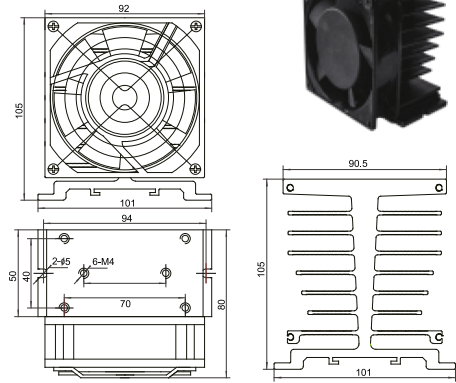
HS_015

General data

Thermal Resistance [°C/W]	0.6
Dimensions H x W x D [mm]	106 x 80 x 96
Weight [gr]	645
Mounting type	Panel (with screws, not incl. in the delivery)
Suitable for solid state relays type	SP1P
Cooling	Air, forced convection (fan) Fan voltage 230 V AC

Product reference

Description	Type	available
Heatsinks (panel mounted with screws)	HS_015	✓



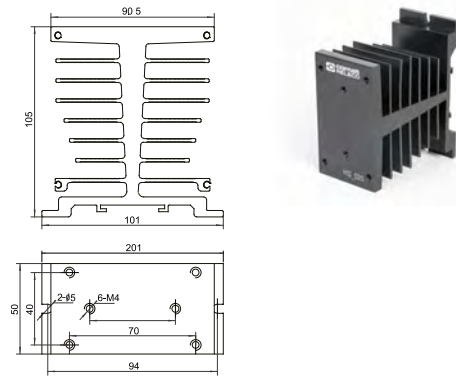
HS_020

General data

Thermal Resistance [°C/W]	1.6
Dimensions H x W x D [mm]	106 x 50 x 96
Weight [gr]	375
Mounting type	Panel (with screws, not incl. in the delivery)
Suitable for solid state relays type	SP1P
Cooling	Air, natural convection

Product reference

Description	Type	available
Heatsinks (panel mounted with screws)	HS_020	✓



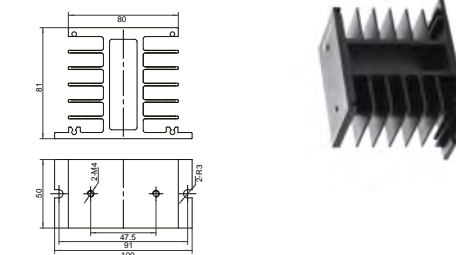
HS_022

General data

Thermal Resistance [°C/W]	1.7
Dimensions H x W x D [mm]	100 x 50 x 81
Weight [gr]	255
Mounting type	Panel (with screws, not incl. in the delivery)
Suitable for solid state relays type	SP1P
Cooling	Air, natural convection

Product reference

Description	Type	available
Heatsinks (panel mounted with screws)	HS_022	✓



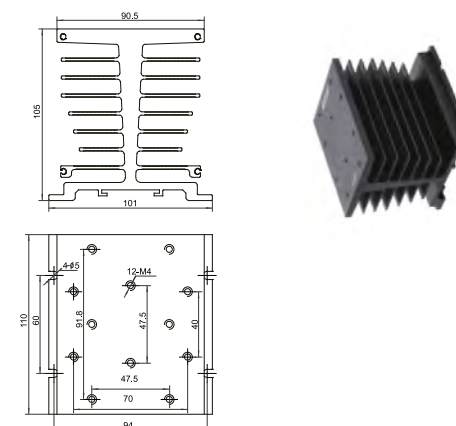
HS_025

General data

Thermal Resistance [°C/W]	0.8
Dimensions H x W x D [mm]	106 x 110 x 96
Weight [gr]	895
Mounting type	Panel (with screws, not incl. in the delivery)
Suitable for solid state relays type	SP1P
Cooling	Air, natural convection

Product reference

Description	Type	available
Heatsinks (panel mounted with screws)	HS_025	✓



SP1M/pad

General data

Dimensions H x W x D [mm] 36.2 x 26.2 x 0.15
 Suitable for solid state relays type SP1M

Product reference

Description	Type	available
Thermal conducting pad	SP1M/pad	✓



SP1P/pad

General data

Dimensions H x W x D [mm] 55 x 42 x 0.15
 Suitable for solid state relays type SP1P

Product reference

Description	Type	available
Thermal conducting pad	SP1P/pad	✓



SP1/grease

General data

Suitable for solid state relays type SP1M, SP1P

Product reference (o.r. = on request)

Description	Type	available
Thermal conducting grease	SP1/grease	o.r.

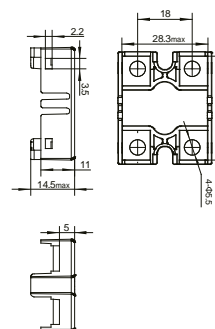
SP1MXN/cover

General data

Dimensions H x W x D [mm] 35.1 x 28.3 x 14.5
 Weight [gr] 6
 Suitable for solid state relays type SP1MXN

Product reference

Description	Type	available
Transparent cover	SP1MXN/cover	✓



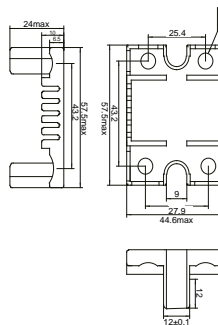
SP1PXN/cover

General data

Dimensions H x W x D [mm]	57.5 x 44.6 x 24
Weight [gr]	10
Suitable for solid state relays type	SP1PXN

Product reference

Description	Type	available
Transparent cover	SP1PXN/cover	✓



4 Solid State Contactor

	Type	Page
CC1 Series		
1 phase 230 V 15 A	CC1H215	86
1 phase 230 V 30 A	CC1H230	87
1 phase 230 V 50 A	CC1H250	88
1 phase 400 V 15 A	CC1H415	89
1 phase 400 V 30 A	CC1H430	90
1 phase 400 V 50 A	CC1H450	91
1 phase 400 V 63 A	CC1H463	92
CC3 Series		
3 phase 400 V 10 A	CC3H410	93
3 phase 400 V 20 A	CC3H420	94
3 phase 400 V 10 A Reversing	CCR3H410	95
CPC Series		
1 phase 230 V 30 A Power Controller	CPC1230	96
1 phase 230 V 50 A Power Controller	CPC1250	97
1 phase 400 V 30 A Power Controller	CPC1430	98
1 phase 400 V 50 A Power Controller	CPC1450	99

CC1H215

1 phase | 230 V | 15 A



Main circuit

Output type	⚡ Thyristor
Number of outputs	1
Rated voltage	230 V AC
Output voltage range	12 ... 240 V AC
Reverse voltage	1000 Vrrm
Peak reverse voltage	1100 Vrrm
Rated current AC-1	15 A
Rated current AC-3	15 A
Recommended minimum contact load	10 mA
Leakage current	1 mA
Rated limit load	1800 A ² t

Control circuit

Nominal voltage	24 ... 230 V UC
Operating voltage range	0.85 ... 1.1 U _N
Pick-up voltage	20.4 V
Release voltage	7.2 V
Pick-up time	20 ms
Release time	20 ms
Power consumption AC / DC	1.5 VA / 150 mW
Rated frequency	50 / 60 Hz

Insulation

Rated insulation voltage	660 V
Rated impulse withstand voltage open contact	4 kV / 1 min
Pollution degree	3
Overvoltage category	III

General data

Ambient temperature storage (no ice)	-20 ... 80 °C
Ambient temperature operation	-5 ... 40 °C
Ambient temperature operation derated power	-5 ... 60 °C, 0.7 I _N
Conductor cross section control / main circuit	1.5 mm ² / 10 mm ²
Nominal screw torque control / main circuit	0.5 Nm / 1.2 Nm
Dimension	fig. 2
Weight	270 g
Protection degree	IP 20
Housing material	PPE
Mounting	TS 35 or Back Panel Mounting

Product reference

Description	Type
Solid State Contactor, 1 phase	CC1H215

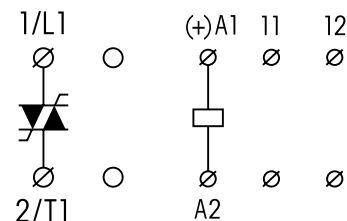
Other devices on request. Please contact support@comatreleco.com.

Accessories

Thermal overload protection	P82-100C
-----------------------------	----------

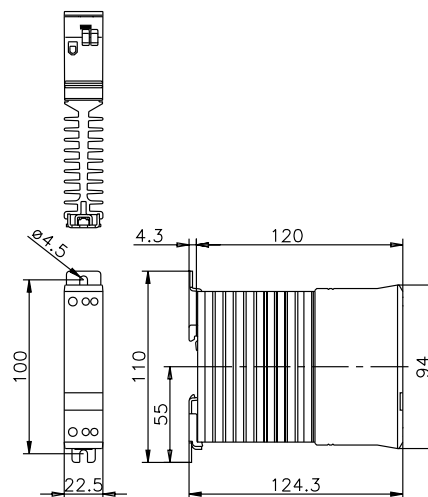


fig. 1. Wiring diagram



11-12: Thermostat

fig. 2. Dimension (mm)



Standards and approvals

Standards IEC/EN 60947, 50022, 60068

Approvals

CC1H230

1 phase | 230 V | 30 A

Main circuit

Output type	⚡ Thyristor
Number of outputs	1
Rated voltage	230 V AC
Output voltage range	12 ... 240 V AC
Reverse voltage	1000 Vrrm
Peak reverse voltage	1100 Vrrm
Rated current AC-1	30 A
Rated current AC-3	15 A
Recommended minimum contact load	10 mA
Leakage current	1 mA
Rated limit load	1800 A ² t

Control circuit

Nominal voltage	24 ... 230 V UC
Operating voltage range	0.85 ... 1.1 U _N
Pick-up voltage	20.4 V
Release voltage	7.2 V
Pick-up time	20 ms
Release time	20 ms
Power consumption AC / DC	1.5 VA / 150 mW
Rated frequency	50 / 60 Hz

Insulation

Rated insulation voltage	660 V
Rated impulse withstand voltage open contact	4 kV / 1 min
Pollution degree	3
Overvoltage category	III

General data

Ambient temperature storage (no ice)	-20 ... 80 °C
Ambient temperature operation	-5 ... 40 °C
Ambient temperature operation derated power	-5 ... 60 °C, 0.7 I _N
Conductor cross section control / main circuit	1.5 mm ² / 10 mm ²
Nominal screw torque control / main circuit	0.5 Nm / 1.2 Nm
Dimension	fig. 2
Weight	650 g
Protection degree	IP 20
Housing material	PPE
Mounting	TS 35 or Back Panel Mounting

Product reference

Description	Type
Solid State Contactor, 1 phase	CC1H230

Other devices on request. Please contact support@comatreleco.com.

Accessories

Thermal overload protection	P82-100C
-----------------------------	----------

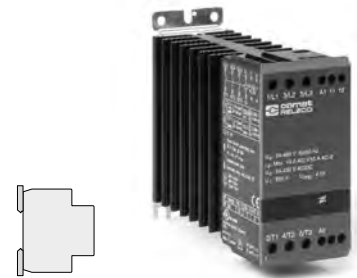
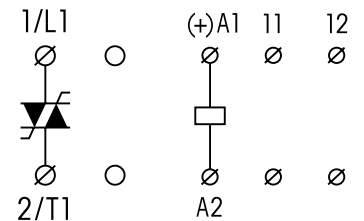
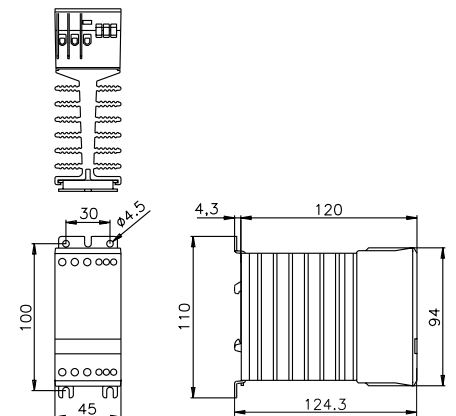


fig. 1. Wiring diagram



11-12: Thermostat

fig. 2. Dimension (mm)



Standards and approvals

Standards IEC/EN 60947, 50022, 60068

Approvals

CC1H250

1 phase | 230 V | 50 A

Main circuit

Output type	⚡ Thyristor
Number of outputs	1
Rated voltage	230 V AC
Output voltage range	12 ... 240 V AC
Reverse voltage	1000 V _{rrm}
Peak reverse voltage	1100 V _{rrm}
Rated current AC-1	50 A
Rated current AC-3	15 A
Recommended minimum contact load	10 mA
Leakage current	1 mA
Rated limit load	1800 A ² t

Control circuit

Nominal voltage	24 ... 230 V UC
Operating voltage range	0.85 ... 1.1 U _N
Pick-up voltage	20.4 V
Release voltage	7.2 V
Pick-up time	20 ms
Release time	20 ms
Power consumption AC / DC	1.5 VA / 150 mW
Rated frequency	50 / 60 Hz

Insulation

Rated insulation voltage	660 V
Rated impulse withstand voltage open contact	4 kV / 1 min
Pollution degree	3
Overvoltage category	III

General data

Ambient temperature storage (no ice)	-20 ... 80 °C
Ambient temperature operation	-5 ... 40 °C
Ambient temperature operation derated power	-5 ... 60 °C, 0.7 I _N
Conductor cross section control / main circuit	1.5 mm ² / 10 mm ²
Nominal screw torque control / main circuit	0.5 Nm / 1.2 Nm
Dimension	fig. 2
Weight	1050 g
Protection degree	IP 20
Housing material	PPE
Mounting	TS 35 or Back Panel Mounting

Product reference

Description	Type
Solid State Contactor, 1 phase	CC1H250

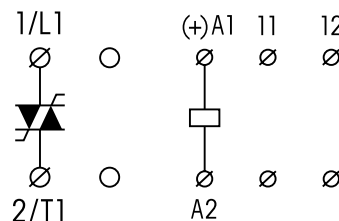
Other devices on request. Please contact support@comatreleco.com.

Accessories

Thermal overload protection	P82-100C
-----------------------------	----------

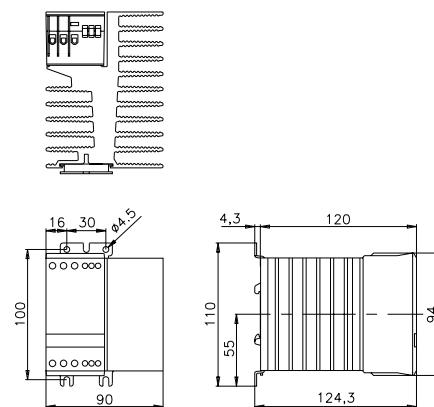


fig. 1. Wiring diagram



11-12: Thermostat

fig. 2. Dimension (mm)



Standards and approvals

Standards IEC/EN 60947, 50022, 60068

Approvals

CC1H415

1 phase | 400 V | 15 A

Main circuit

Output type	⚡ Thyristor
Number of outputs	1
Rated voltage	400 V AC
Output voltage range	24 ... 480 VAC
Reverse voltage	1200 V _{rrm}
Peak reverse voltage	1300 V _{rrm}
Rated current AC-1	15 A
Rated current AC-3	15 A
Recommended minimum contact load	10 mA
Leakage current	1 mA
Rated limit load	1800 A ² t

Control circuit

Nominal voltage	24 ... 230 V UC
Operating voltage range	0.85 ... 1.1 U _N
Pick-up voltage	20.4 V
Release voltage	7.2 V
Pick-up time	20 ms
Release time	20 ms
Power consumption AC / DC	1.5 VA / 150 mW
Rated frequency	50 / 60 Hz

Insulation

Rated insulation voltage	660 V
Rated impulse withstand voltage open contact	4 kV / 1 min
Pollution degree	3
Overvoltage category	III

General data

Ambient temperature storage (no ice)	-20 ... 80 °C
Ambient temperature operation	-5 ... 40 °C
Ambient temperature operation derated power	-5 ... 60 °C, 0.7 I _N
Conductor cross section control / main circuit	1.5 mm ² / 10 mm ²
Nominal screw torque control / main circuit	0.5 Nm / 1.2 Nm
Dimension	fig. 2
Weight	270 g
Protection degree	IP 20
Housing material	PPE
Mounting	TS 35 or Back Panel Mounting

Product reference

Description	Type
Solid State Contactor, 1 phase	CC1H415

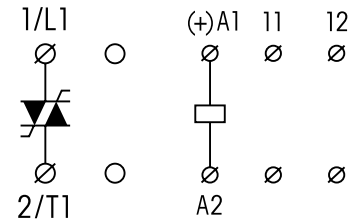
Other devices on request. Please contact support@comatreleco.com.

Accessories

Thermal overload protection	P82-100C
-----------------------------	----------

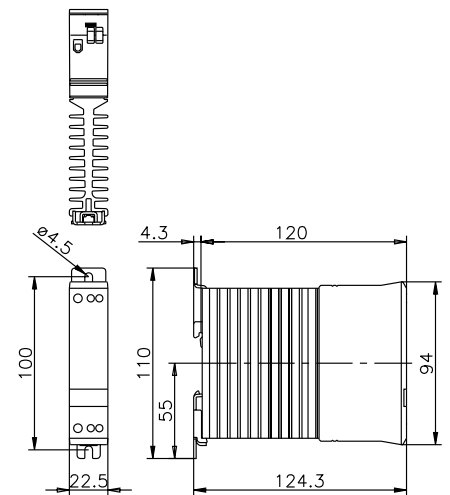


fig. 1. Wiring diagram



11-12: Thermostat

fig. 2. Dimension (mm)



Standards and approvals

Standards IEC/EN 60947, 50022, 60068

Approvals

CC1H430

1 phase | 400 V | 30 A



Main circuit

Output type	⚡ Thyristor
Number of outputs	1
Rated voltage	400 V AC
Output voltage range	24 ... 480 VAC
Reverse voltage	1200 Vrrm
Peak reverse voltage	1300 Vrrm
Rated current AC-1	30 A
Rated current AC-3	15 A
Recommended minimum contact load	10 mA
Leakage current	1 mA
Rated limit load	1800 A ² t

Control circuit

Nominal voltage	24 ... 230 V UC
Operating voltage range	0.85 ... 1.1 U _N
Pick-up voltage	20.4 V
Release voltage	7.2 V
Pick-up time	20 ms
Release time	20 ms
Power consumption AC / DC	1.5 VA / 150 mW
Rated frequency	50 / 60 Hz

Insulation

Rated insulation voltage	660 V
Rated impulse withstand voltage open contact	4 kV / 1 min
Pollution degree	3
Overvoltage category	III

General data

Ambient temperature storage (no ice)	-20 ... 80 °C
Ambient temperature operation	-5 ... 40 °C
Ambient temperature operation derated power	-5 ... 60 °C, 0.7 I _N
Conductor cross section control / main circuit	1.5 mm ² / 10 mm ²
Nominal screw torque control / main circuit	0.5 Nm / 1.2 Nm
Dimension	fig. 2
Weight	650 g
Protection degree	IP 20
Housing material	PPE
Mounting	TS 35 or Back Panel Mounting

Product reference

Description	Type
Solid State Contactor, 1 phase	CC1H430

Other devices on request. Please contact support@comatreleco.com.

Accessories

Thermal overload protection	P82-100C
-----------------------------	----------

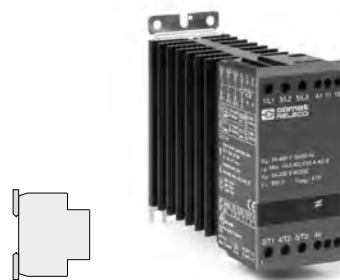
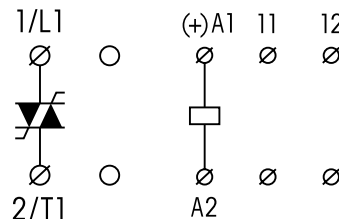
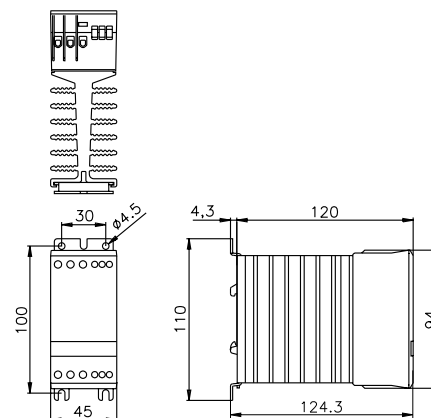


fig. 1. Wiring diagram



11-12: Thermostat

fig. 2. Dimension (mm)



Standards and approvals

Standards IEC/EN 60947, 50022, 60068

Approvals

CC1H450

1 phase | 400 V | 50 A

Main circuit

Output type	⚡ Thyristor
Number of outputs	1
Rated voltage	400 V AC
Output voltage range	24 ... 480 VAC
Reverse voltage	1200 V _{rrm}
Peak reverse voltage	1300 V _{rrm}
Rated current AC-1	50 A
Rated current AC-3	15 A
Recommended minimum contact load	10 mA
Leakage current	1 mA
Rated limit load	1800 A ² t

Control circuit

Nominal voltage	24 ... 230 V UC
Operating voltage range	0.85 ... 1.1 U _N
Pick-up voltage	20.4 V
Release voltage	7.2 V
Pick-up time	20 ms
Release time	20 ms
Power consumption AC / DC	1.5 VA / 150 mW
Rated frequency	50 / 60 Hz

Insulation

Rated insulation voltage	660 V
Rated impulse withstand voltage open contact	4 kV / 1 min
Pollution degree	3
Overtoltage category	III

General data

Ambient temperature storage (no ice)	-20 ... 80 °C
Ambient temperature operation	-5 ... 40 °C
Ambient temperature operation derated power	-5 ... 60 °C, 0.7 I _N
Conductor cross section control / main circuit	1.5 mm ² / 10 mm ²
Nominal screw torque control / main circuit	0.5 Nm / 1.2 Nm
Dimension	fig. 2
Weight	1050 g
Protection degree	IP 20
Housing material	PPE
Mounting	TS 35 or Back Panel Mounting

Product reference

Description	Type
Solid State Contactor, 1 phase	CC1H450

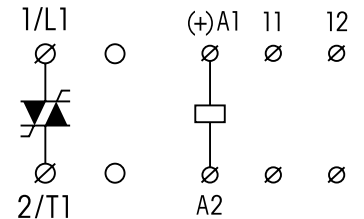
Other devices on request. Please contact support@comatreleco.com.

Accessories

Thermal overload protection	P82-100C
-----------------------------	----------

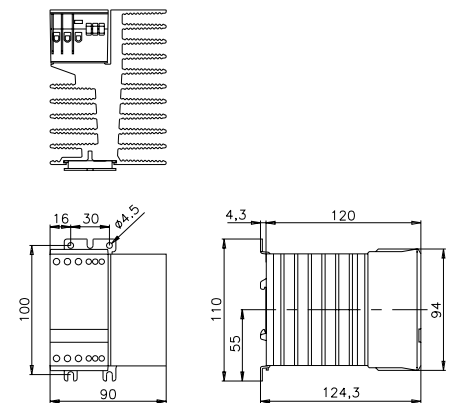


fig. 1. Wiring diagram



11-12: Thermostat

fig. 2. Dimension (mm)



Standards and approvals

Standards IEC/EN 60947, 50022, 60068

Approvals

CC1H463

1 phase | 400 V | 63 A



Main circuit

Output type	⚡ Thyristor
Number of outputs	1
Rated voltage	400 V AC
Output voltage range	24 ... 480 VAC
Reverse voltage	1200 Vrrm
Peak reverse voltage	1300 Vrrm
Rated current AC-1	63 A
Rated current AC-3	30 A
Recommended minimum contact load	10 mA
Leakage current	1 mA
Rated limit load	1800 A ² t

Control circuit

Nominal voltage	24 ... 230 V UC
Operating voltage range	0.85 ... 1.1 U _N
Pick-up voltage	20.4 V
Release voltage	7.2 V
Pick-up time	20 ms
Release time	20 ms
Power consumption AC / DC	1.5 VA / 150 mW
Rated frequency	50 / 60 Hz

Insulation

Rated insulation voltage	660 V
Rated impulse withstand voltage open contact	4 kV / 1 min
Pollution degree	3
Overvoltage category	III

General data

Ambient temperature storage (no ice)	-20 ... 80 °C
Ambient temperature operation	-5 ... 40 °C
Ambient temperature operation derated power	-5 ... 60 °C, 0.7 I _N
Conductor cross section control / main circuit	1.5 mm ² / 10 mm ²
Nominal screw torque control / main circuit	0.5 Nm / 1.2 Nm
Dimension	fig. 2
Weight	1050 g
Protection degree	IP 20
Housing material	PPE
Mounting	TS 35 or Back Panel Mounting

Product reference

Description	Type
Solid State Contactor, 1 phase	CC1H463

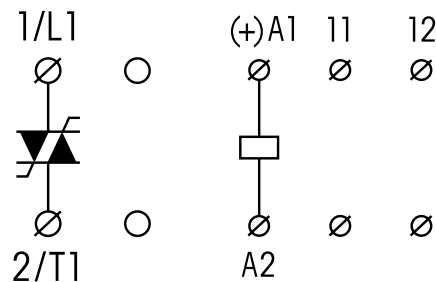
Other devices on request. Please contact support@comatreleco.com.

Accessories

Thermal overload protection	P82-100C
-----------------------------	----------

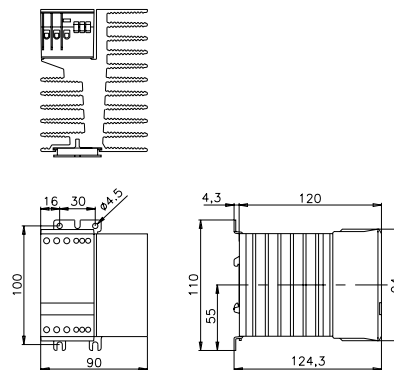


fig. 1. Wiring diagram



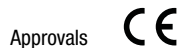
11-12: Thermostat

fig. 2. Dimension (mm)



Standards and approvals

Standards IEC/EN 60947



Approvals

CC3H410

3 phase | 400 V | 10 A

Main circuit

Output type	⚡ Thyristor
Number of outputs	3
Rated voltage	400 V AC
Output voltage range	24 ... 480 VAC
Reverse voltage	1200 Vrrm
Peak reverse voltage	1300 Vrrm
Rated current AC-1	10 A
Rated current AC-3	10 A
Recommended minimum contact load	10 mA
Leakage current	1 mA
Rated limit load	610 A ² t

Control circuit

Nominal voltage	24 ... 230 V UC
Operating voltage range	0.85 ... 1.1 U _N
Pick-up voltage	20.4 V
Release voltage	7.2 V
Pick-up time	20 ms
Release time	20 ms
Power consumption AC / DC	1.5 VA / 150 mW
Rated frequency	50 / 60 Hz

Insulation

Rated insulation voltage	660 V
Rated impulse withstand voltage open contact	4 kV / 1 min
Pollution degree	3
Overvoltage category	III

General data

Ambient temperature storage (no ice)	-20 ... 80 °C
Ambient temperature operation	-5 ... 40 °C
Ambient temperature operation derated power	-5 ... 60 °C, 0.7 I _N
Conductor cross section control / main circuit	1.5 mm ² / 10 mm ²
Nominal screw torque control / main circuit	0.5 Nm / 1.2 Nm
Dimension	fig. 2
Weight	650 g
Protection degree	IP 20
Housing material	PPE
Mounting	TS 35 or Back Panel Mounting

Product reference

Description	Type
Solid State Contactor, 3 phase	CC3H410

Other devices on request. Please contact support@comatreleco.com.

Accessories

Thermal overload protection	P82-100C
-----------------------------	----------

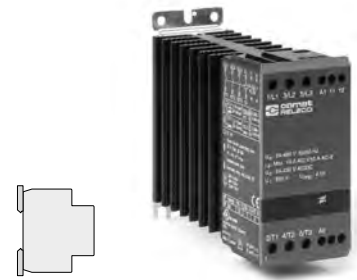
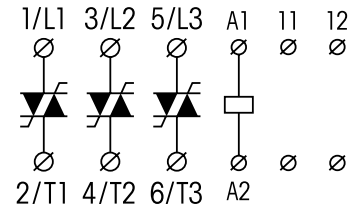
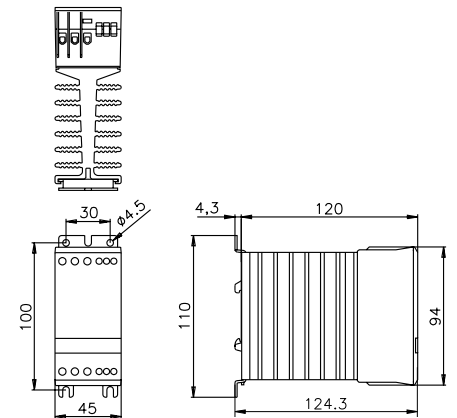


fig. 1. Wiring diagram



11-12: Thermostat

fig. 2. Dimension (mm)



Standards and approvals

Standards IEC/EN 60947, 50022, 60068

Approvals

CC3H420

3 phase | 400 V | 20 A



Main circuit

Output type	Thyristor
Number of outputs	3
Rated voltage	400 V AC
Output voltage range	24 ... 480 VAC
Reverse voltage	1200 V _{rrm}
Peak reverse voltage	1300 V _{rrm}
Rated current AC-1	20 A
Rated current AC-3	10 A
Recommended minimum contact load	10 mA
Leakage current	1 mA
Rated limit load	610 A ² t

Control circuit

Nominal voltage	24 ... 230 V UC
Operating voltage range	0.85 ... 1.1 U _N
Pick-up voltage	20.4 V
Release voltage	7.2 V
Pick-up time	20 ms
Release time	20 ms
Power consumption AC / DC	1.5 VA / 150 mW
Rated frequency	50 / 60 Hz

Insulation

Rated insulation voltage	660 V
Rated impulse withstand voltage open contact	4 kV / 1 min
Pollution degree	3
Overvoltage category	III

General data

Ambient temperature storage (no ice)	-20 ... 80 °C
Ambient temperature operation	-5 ... 40 °C
Ambient temperature operation derated power	-5 ... 60 °C, 0.7 I _N
Conductor cross section control / main circuit	1.5 mm ² / 10 mm ²
Nominal screw torque control / main circuit	0.5 Nm / 1.2 Nm
Dimension	fig. 2
Weight	1050 g
Protection degree	IP 20
Housing material	PPE
Mounting	TS 35 or Back Panel Mounting

Product reference

Description	Type
Solid State Contactor, 3 phase	CC3H420

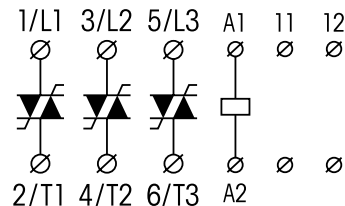
Other devices on request. Please contact support@comatreleco.com.

Accessories

Thermal overload protection	P82-100C
-----------------------------	----------

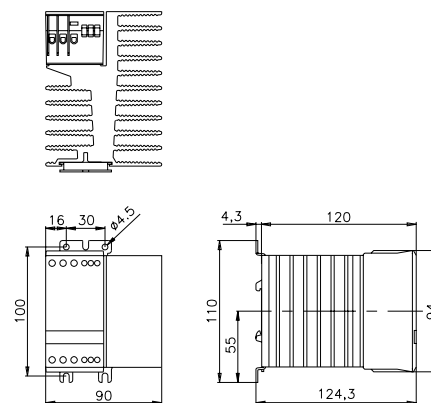


fig. 1. Wiring diagram



11-12: Thermostat

fig. 2. Dimension (mm)



Standards and approvals

Standards IEC/EN 60947, 50022, 60068

Approvals

CCR3H410

3 phase | 400 V | 10 A | Reversing

Main circuit

Output type	⚡ Thyristor
Number of outputs	3
Rated voltage	400 V AC
Output voltage range	24 ... 480 VAC
Reverse voltage	1200 V _{rrm}
Peak reverse voltage	1300 V _{rrm}
Rated current AC-1	10 A
Rated current AC-3	10 A
Recommended minimum contact load	10 mA
Leakage current	1 mA
Rated limit load	610 A ² t

Control circuit

Nominal voltage	24 ... 230 V UC
Operating voltage range	0.85 ... 1.1 U _N
Pick-up voltage	20.4 V
Release voltage	7.2 V
Pick-up time	20 ms
Release time	20 ms
Interlock time	150 ms
Power consumption AC / DC	1.5 VA / 150 mW
Rated frequency	50 / 60 Hz

Insulation

Rated insulation voltage	660 V
Rated impulse withstand voltage open contact	4 kV / 1 min
Pollution degree	3
Overvoltage category	III

General data

Ambient temperature storage (no ice)	-20 ... 80 °C
Ambient temperature operation	-5 ... 40 °C
Ambient temperature operation derated power	-5 ... 60 °C, 0.7 I _N
Conductor cross section control / main circuit	1.5 mm ² / 10 mm ²
Nominal screw torque control / main circuit	0.5 Nm / 1.2 Nm
Dimension	fig. 2
Weight	650 g
Protection degree	IP 20
Housing material	PPE
Mounting	TS 35 or Back Panel Mounting

Product reference

Description	Type
Solid State Contactor - Reversing, 3 phase	CCR3H410

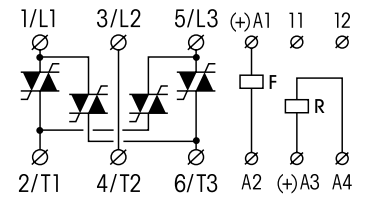
Other devices on request. Please contact support@comatreleco.com.

Accessories

Thermal overload protection	P82-100C
-----------------------------	----------

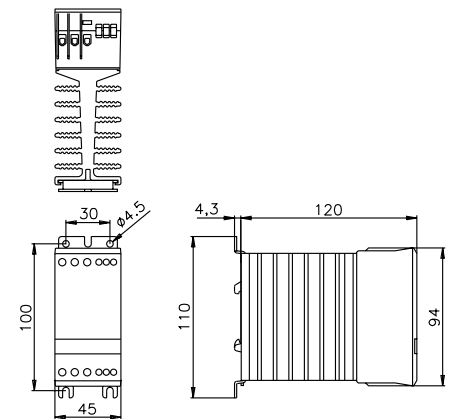


fig. 1. Wiring diagram



11-12: Thermostat

fig. 2. Dimension (mm)



Standards and approvals

Standards IEC/EN 60947, 50022, 60068

Approvals

CPC1230

1 phase | 230 V | 30 A | Power Controller



Main circuit

Output type	⚡ Thyristor
Number of outputs	1
Rated voltage	230 V AC
Output voltage range	380 ... 480 V
Reverse voltage	1000 Vrrm
Peak reverse voltage	1100 Vrrm
Rated current AC-1	30 A
Recommended minimum contact load	10 mA
Leakage current	1 mA
Rated limit load	1800 A ² t

Control circuit

Nominal voltage	24 V UC
Operating voltage range	0.5 ... 1.5 U _N
Pick-up voltage	≤ 12 V
Release voltage	≥ 12 V
Pick-up time	20 ms
Release time	20 ms
Control input	0 ... 20 mA / 4 ... 20 mA / 0 - 10 V
Potentiometer input	0 - 10 kOhm

Insulation

Rated insulation voltage	660 V
Rated impulse withstand voltage open contact	4 kV / 1 min
Pollution degree	3
Overvoltage category	III

General data

Ambient temperature storage (no ice)	-20 ... 80 °C
Ambient temperature operation	-5 ... 40 °C
Ambient temperature operation derated power	-5 ... 60 °C, 0.7 I _N
Conductor cross section control / main circuit	1.5 mm ² / 10 mm ²
Nominal screw torque control / main circuit	0.5 Nm / 1.2 Nm
Dimension	fig. 2
Weight	650 g
Protection degree	IP 20
Housing material	PPE
Mounting	TS 35 or Back Panel Mounting

Product reference

Description	Type
Power Controller, 1 phase	CPC1230

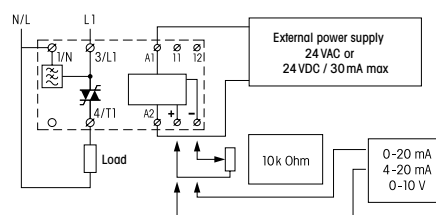
Other devices on request. Please contact support@comatreleco.com.

Accessories

Thermal overload protection	P82-100C
-----------------------------	----------

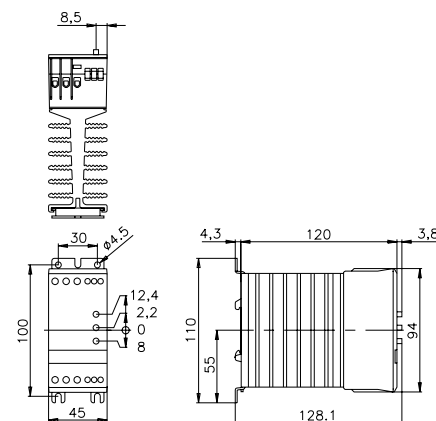


fig. 1. Wiring diagram



11-12: Thermostat

fig. 2. Dimension (mm)



Standards and approvals

Standards IEC/EN 60947, 50022, 60068

Approvals

CPC1250

1 phase | 230 V | 50 A | Power Controller

Main circuit

Output type	⚡ Thyristor
Number of outputs	1
Rated voltage	230 V AC
Output voltage range	380 ... 480 V
Reverse voltage	1000 V _{rrm}
Peak reverse voltage	1100 V _{rrm}
Rated current AC-1	50 A
Recommended minimum contact load	10 mA
Leakage current	1 mA
Rated limit load	1800 A ² t

Control circuit

Nominal voltage	24 V UC
Operating voltage range	0.5 ... 1.5 U _N
Pick-up voltage	≤ 12 V
Release voltage	≥ 12 V
Pick-up time	20 ms
Release time	20 ms
Control input	0 ... 20 mA / 4 ... 20 mA / 0 - 10 V
Potentiometer input	0 - 10 kOhm

Insulation

Rated insulation voltage	660 V
Rated impulse withstand voltage open contact	4 kV / 1 min
Pollution degree	3
Overvoltage category	III

General data

Ambient temperature storage (no ice)	-20 ... 80 °C
Ambient temperature operation	-5 ... 40 °C
Ambient temperature operation derated power	-5 ... 60 °C, 0.7 I _N
Conductor cross section control / main circuit	1.5 mm ² / 10 mm ²
Nominal screw torque control / main circuit	0.5 Nm / 1.2 Nm
Dimension	fig. 2
Weight	650 g
Protection degree	IP 20
Housing material	PPE
Mounting	TS 35 or Back Panel Mounting

Product reference

Description	Type
Power Controller, 1 phase	CPC1250

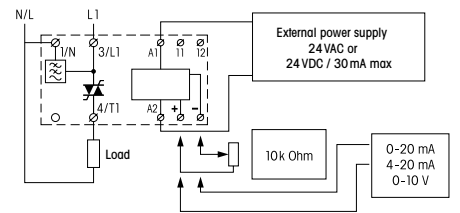
Other devices on request. Please contact support@comatreleco.com.

Accessories

Thermal overload protection	P82-100C
-----------------------------	----------

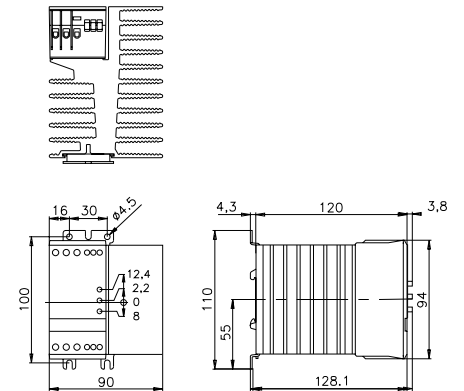


fig. 1. Wiring diagram



11-12: Thermostat

fig. 2. Dimension (mm)



Standards and approvals

Standards IEC/EN 60947, 50022, 60068

Approvals

CPC1430

1 phase | 400 V | 30 A | Power Controller



Main circuit

Output type	⚡ Thyristor
Number of outputs	1
Rated voltage	400 V AC
Output voltage range	380 ... 480 V
Reverse voltage	1200 Vrrm
Peak reverse voltage	1300 Vrrm
Rated current AC-1	30 A
Recommended minimum contact load	10 mA
Leakage current	1 mA
Rated limit load	1800 A ² t

Control circuit

Nominal voltage	24 V UC
Operating voltage range	0.5 ... 1.5 U _N
Pick-up voltage	≤ 12 V
Release voltage	≥ 12 V
Pick-up time	20 ms
Release time	20 ms
Control input	0 ... 20 mA / 4 ... 20 mA / 0 - 10 V
Potentiometer input	0 - 10 kOhm

Insulation

Rated insulation voltage	660 V
Rated impulse withstand voltage open contact	4 kV / 1 min
Pollution degree	3
Overvoltage category	III

General data

Ambient temperature storage (no ice)	-20 ... 80 °C
Ambient temperature operation	-5 ... 40 °C
Ambient temperature operation derated power	-5 ... 60 °C, 0.7 I _N
Conductor cross section control / main circuit	1.5 mm ² / 10 mm ²
Nominal screw torque control / main circuit	0.5 Nm / 1.2 Nm
Dimension	fig. 2
Weight	650 g
Protection degree	IP 20
Housing material	PPE
Mounting	TS 35 or Back Panel Mounting

Product reference

Description	Type
Power Controller, 1 phase	CPC1430

Other devices on request. Please contact support@comatreleco.com.

Accessories

Thermal overload protection	P82-100C
-----------------------------	----------

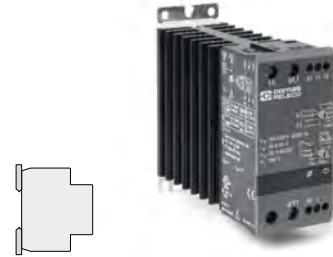
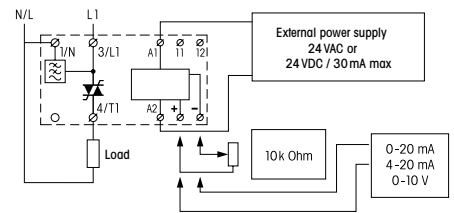
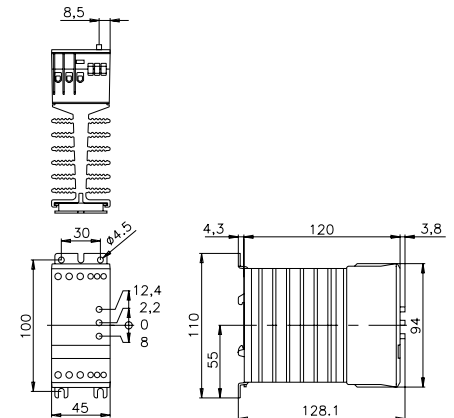


fig. 1. Wiring diagram



11-12: Thermostat

fig. 2. Dimension (mm)



Standards and approvals

Standards IEC/EN 60947, 50022, 60068

Approvals

CPC1450

1 phase | 400 V | 50 A | Power Controller



Main circuit

Output type	⚡ Thyristor
Number of outputs	1
Rated voltage	400 V AC
Output voltage range	380 ... 480 V
Reverse voltage	1200 Vrrm
Peak reverse voltage	1300 Vrrm
Rated current AC-1	50 A
Recommended minimum contact load	10 mA
Leakage current	1 mA
Rated limit load	1800 A ² t

Control circuit

Nominal voltage	24 V UC
Operating voltage range	0.5 ... 1.5 U _N
Pick-up voltage	≤ 12 V
Release voltage	≥ 12 V
Pick-up time	20 ms
Release time	20 ms
Control input	0 ... 20 mA / 4 ... 20 mA / 0 - 10 V
Potentiometer input	0 - 10 kOhm

Insulation

Rated insulation voltage	660 V
Rated impulse withstand voltage open contact	4 kV / 1 min
Pollution degree	3
Overvoltage category	III

General data

Ambient temperature storage (no ice)	-20 ... 80 °C
Ambient temperature operation	-5 ... 40 °C
Ambient temperature operation derated power	-5 ... 60 °C, 0.7 I _N
Conductor cross section control / main circuit	1.5 mm ² / 10 mm ²
Nominal screw torque control / main circuit	0.5 Nm / 1.2 Nm
Dimension	fig. 2
Weight	650 g
Protection degree	IP 20
Housing material	PPE
Mounting	TS 35 or Back Panel Mounting

Product reference

Description	Type
Power Controller, 1 phase	CPC1450

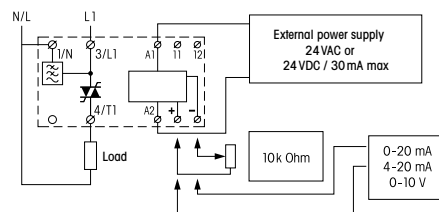
Other devices on request. Please contact support@comatreleco.com.

Accessories

Thermal overload protection	P82-100C
-----------------------------	----------

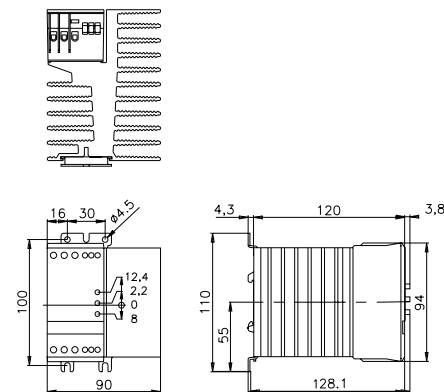


fig. 1. Wiring diagram



11-12: Thermostat

fig. 2. Dimension (mm)



Standards and approvals

Standards IEC/EN 60947, 50022, 60068

Approvals

5 Softstarter

Chapter	Page
5.1 Softstarter	103
5.2 DC Motor Controller	119

5.1 Softstarter

	Type	Page
CTC Series		
3 phase 400 V 15 A Starting Torque Limiter	CTC3415	104
3 phase 400 V 25 A Starting Torque Limiter	CTC3425	105
CCL Series		
3 phase 400 V 15 A Compressor Starting Torque Limiter	CCL33H415US	106
3 phase 400 V 25 A Compressor Starting Torque Limiter	CCL33H425US	107
3 phase 400 V 35 A Compressor Starting Torque Limiter	CCL33H435US	108
CCM Series		
3 phase 400 V 3 A Starting Torque Limiter	CCM3H403USi	109
3 phase 400 V 15 A Starting Torque Limiter	CCM3H415	110
3 phase 400 V 15 A Starting Torque Limiter with direct switch	CCM3H415DS	111
3 phase 400 V 25 A Starting Torque Limiter	CCM3H425	112
3 phase 480 V 25 A Starting Torque Limiter	CCM33H425US	113
3 phase 480 V 50 A Starting Torque Limiter	CCM33H450US	114
3 phase 480 V 30 A Starting Torque Limiter	CCM33H530USi	115
3 phase 480 V 50 A Starting Torque Limiter	CCM33H550USi	116
3 phase 400 V 25 A Starting Torque Limiter with dynamic brake	CCMB3H425	117
Accessories		
Thermal overload protection	P82-100C	118

CTC3415

3 phase | 400 V | 15 A | Starting Torque Limiter



Main circuit

Number of outputs	3
Controlled phases	1
Output type	⚡ Thyristor
Rated voltage	400 V
Output voltage range	208 ... 400 V AC
Reverse voltage	1200 V _{rrm}
Peak reverse voltage	1300 V _{rrm}
Rated current AC-53a	15 A
Minimum load	50 mA
Leakage current	5 mA
Rated limit load	1800 A ^t
Switching frequency (cycles / h)	3000

Control circuit

Release time	1 Periode
Ramp-up time	0.5 ... 5 s
Torque adjustment	0 ... 85 %
Rated frequency	50 / 60 Hz

Insulation

Rated insulation voltage	660 V
Rated impulse withstand voltage open contact	4 kV / 1 min
Pollution degree	3
Overvoltage category	III

General data

Ambient temperature storage (no ice)	-20 ... 80 °C
Ambient temperature operation	-5 ... 40 °C
Ambient temperature operation derated power	-5 ... 60 °C, 0.7 I _N
Conductor cross section control / main circuit	1.5 mm ² / 4 mm ²
Nominal screw torque control / main circuit	0.5 Nm / 1.2 Nm
Dimension	fig. 2
Weight	650 g
Protection degree	IP 20
Housing material	PPO
Mounting	TS 35 or Back Panel Mounting

Product references

Description	Type
Starting Torque Limiter, 3 phase	CTC3415

Other devices on request. Please contact support@comatreleco.com.

Accessories

Thermal overload protection	P82-100C
-----------------------------	----------



fig. 1. Wiring diagram

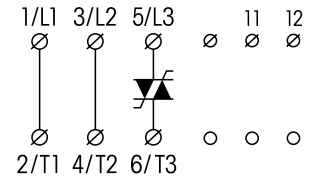
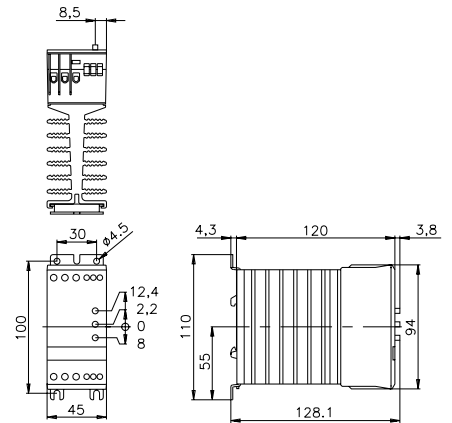


fig. 2. Dimension (mm)



Technical approvals, conformities

Standards IEC/EN 60947-2

Approvals

5.1 Softstarter

CTC3425

3 phase | 400 V | 25 A | Starting Torque Limiter

Main circuit

Number of outputs	3
Controlled phases	1
Output type	⚡ Thyristor
Rated voltage	400 V
Output voltage range	208 ... 400 V AC
Reverse voltage	1200 Vrrm
Peak reverse voltage	1300 Vrrm
Rated current AC-53a	25 A
Minimum load	50 mA
Leakage current	5 mA
Rated limit load	6300 A²t
Switching frequency (cycles / h)	3000

Control circuit

Release time	1 Periode
Ramp-up time	0.5 ... 5 s
Torque adjustment	0 ... 85 %
Rated frequency	50 / 60 Hz

Insulation

Rated insulation voltage	660 V
Rated impulse withstand voltage open contact	4 kV / 1 min
Pollution degree	3
Overvoltage category	III

General data

Ambient temperature storage (no ice)	-20 ... 80 °C
Ambient temperature operation	-5 ... 40 °C
Ambient temperature operation derated power	-5 ... 60 °C, 0.7 I _N
Conductor cross section control / main circuit	1.5 mm² / 4 mm²
Nominal screw torque control / main circuit	0.5 Nm / 1.2 Nm
Dimension	fig. 2
Weight	650 g
Protection degree	IP 20
Housing material	PPO
Mounting	TS 35 or Back Panel Mounting

Product references

Description	Type
Starting Torque Limiter, 3 phase	CTC3425

Other devices on request. Please contact support@comatreleco.com.

Accessories

Thermal overload protection	P82-100C
-----------------------------	----------



fig. 1. Wiring diagram

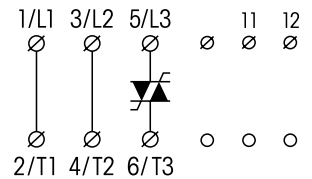
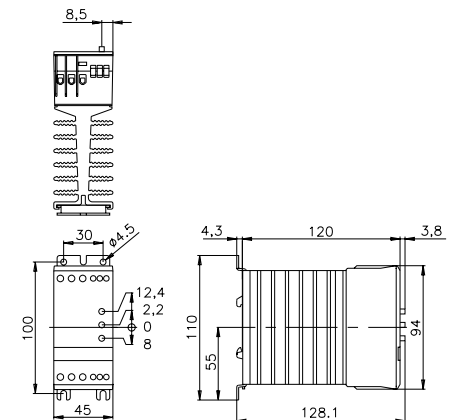


fig. 2. Dimension (mm)



Technical approvals, conformities

Standards IEC/EN 60947-2

Approvals

5.1 Softstarter

CCL33H415US

3 phase | 400 V | 15 A | Compressor Starting Torque Limiter

Main circuit

Number of outputs	3
Controlled phases	3
Output type	⚡ Thyristor
Bypass	Integrated
Rated voltage	400 V
Output voltage range	230 ... 400 V AC
Reverse voltage	1200 V _{rrm}
Peak reverse voltage	1300 V _{rrm}
Rated current AC-58	15 A
Minimum load	1.5 A
Leakage current	5 mA
Inrush current	90 A, 1 s
Rated limit load	610 A ² t
Switching frequency (cycles / h)	12

Control circuit

Nominal voltage	230 V AC
Operating voltage range	0.85 ... 1.15 U _N
Release voltage	110 V AC
Pick-up time	500 ms
Release time	500 ms

Insulation

Rated insulation voltage	660 V
Rated impulse withstand voltage open contact	4 kV / 1 min
Pollution degree	3
Overvoltage category	III

General data

Ambient temperature storage (no ice)	-20 ... 80 °C
Ambient temperature operation	-20 ... 65 °C
Conductor cross section control / main circuit	2.5 mm ² / 6 mm ²
Dimension	fig. 2
Weight	470 g
Protection degree	IP 20
Housing material	PPE
Mounting	TS 35 or Back Panel Mounting

Product references

Description	Type
Compressor Starting Torque Limiter, 3 phase	CCL33H415US

Other devices on request. Please contact support@comatreleco.com.



fig. 1. Wiring diagram

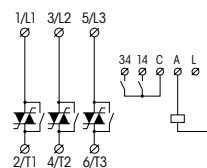
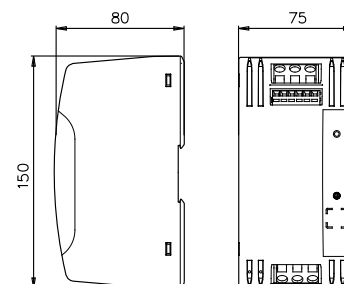


fig. 2. Dimension (mm)



Technical approvals, conformities

Standards IEC/EN 60947-4-2

Approvals

5.1 Softstarter

CCL33H425US

3 phase | 400 V | 25 A | Compressor Starting Torque Limiter

Main circuit

Number of outputs	3
Controlled phases	3
Output type	⚡ Thyristor
Bypass	Integrated
Rated voltage	400 V
Output voltage range	230 ... 400 V AC
Reverse voltage	1200 V _{rrm}
Peak reverse voltage	1300 V _{rrm}
Rated current AC-58	25 A
Minimum load	2.5 A
Leakage current	5 mA
Inrush current	150 A, 1 s
Rated limit load	1800 A ² t
Switching frequency (cycles / h)	12

Control circuit

Nominal voltage	230 V AC
Operating voltage range	0.85 ... 1.15 U _N
Release voltage	110 V AC
Pick-up time	500 ms
Release time	500 ms

Insulation

Rated insulation voltage	660 V
Rated impulse withstand voltage open contact	4 kV / 1 min
Pollution degree	3
Overvoltage category	III

General data

Ambient temperature storage (no ice)	-20 ... 80 °C
Ambient temperature operation	-20 ... 65 °C
Conductor cross section control / main circuit	2.5 mm ² / 6 mm ²
Dimension	fig. 2
Weight	470 g
Protection degree	IP 20
Housing material	PPE
Mounting	TS 35 or Back Panel Mounting

Product references

Description	Type
Compressor Starting Torque Limiter, 3 phase	CCL33H425US

Other devices on request. Please contact support@comatreleco.com.



fig. 1. Wiring diagram

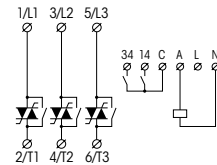
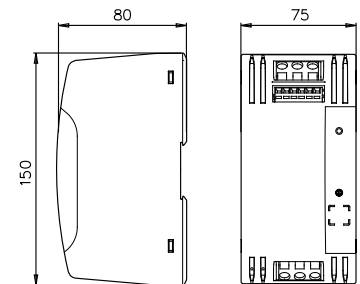


fig. 2. Dimension (mm)



Technical approvals, conformities

Standards IEC/EN 60947-4-2

Approvals

5.1 Softstarter

CCL33H435US

3 phase | 400 V | 35 A | Compressor Starting Torque Limiter

Main circuit

Number of outputs	3
Controlled phases	3
Output type	⚡ Thyristor
Bypass	Integrated
Rated voltage	400 V
Output voltage range	230 ... 400 V AC
Reverse voltage	1200 V _{rrm}
Peak reverse voltage	1300 V _{rrm}
Rated current AC-58	35 A
Minimum load	3.5 A
Leakage current	5 mA
Inrush current	210 A, 1 s
Rated limit load	1800 A ^t
Switching frequency (cycles / h)	12

Control circuit

Nominal voltage	230 V AC
Operating voltage range	0.85 ... 1.15 U _N
Release voltage	110 V AC
Pick-up time	500 ms
Release time	500 ms

Insulation

Rated insulation voltage	660 V
Rated impulse withstand voltage open contact	4 kV / 1 min
Pollution degree	3
Overvoltage category	III

General data

Ambient temperature storage (no ice)	-20 ... 80 °C
Ambient temperature operation	-20 ... 65 °C
Conductor cross section control / main circuit	2.5 mm ² / 6 mm ²
Dimension	fig. 2
Weight	470 g
Protection degree	IP 20
Housing material	PPE
Mounting	TS 35 or Back Panel Mounting

Product references

Description	Type
Compressor Starting Torque Limiter, 3 phase	CCL33H435US

Other devices on request. Please contact support@comatreleco.com.



fig. 1. Wiring diagram

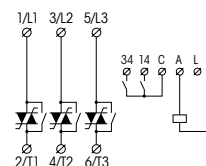
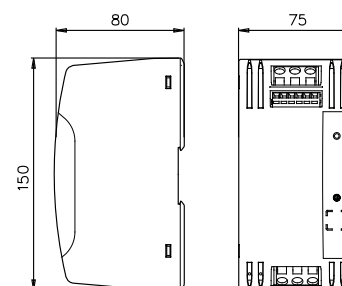


fig. 2. Dimension (mm)



Technical approvals, conformities

Standards IEC/EN 60947-4-2

Approvals

5.1 Softstarter

CCM3H403USi

3 phase | 400 V | 3 A | Starting Torque Limiter

Main circuit

Number of outputs	3
Controlled phases	2
Output type	⚡ Thyristor
Bypass	Integrated
Rated voltage	400 V
Output voltage range	400 ... 480 V AC
Reverse voltage	1200 V _{rrm}
Peak reverse voltage	1300 V _{rrm}
Rated current AC-53b	3 A
Minimum load	250 mA
Leakage current	5 mA
Inrush current	18 A
Rated limit load	72 A ^{2t}
Switching frequency (cycles / h)	120

Control circuit

Nominal voltage	400 V AC
Ramp-up time	0.5 ... 10 s
Ramp-down time	0.5 ... 10 s
Torque adjustment	0 ... 85 %
Rated frequency	50 / 60 Hz

Insulation

Rated insulation voltage	660 V
Rated impulse withstand voltage open contact	4 kV / 1 min
Pollution degree	3
Overvoltage category	III

General data

Ambient temperature storage (no ice)	-20 ... 80 °C
Ambient temperature operation	-5 ... 40 °C
Ambient temperature operation derated power	-5 ... 60 °C
Conductor cross section control / main circuit	2.5 mm ² / 4 mm ²
Nominal screw torque control / main circuit	0.5 Nm / 1.2 Nm
Dimension	fig. 2
Weight	270 g
Protection degree	IP 20
Housing material	PPO
Mounting	TS 35 or Back Panel Mounting

Product references

Description	Type
Starting Torque Limiter, 3 phase	CCM3H403USi

Other devices on request. Please contact support@comatreleco.com.

Accessories

Thermal overload protection	P82-100C
-----------------------------	----------



fig. 1. Wiring diagram

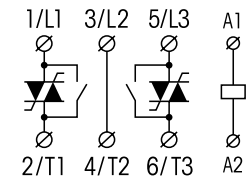
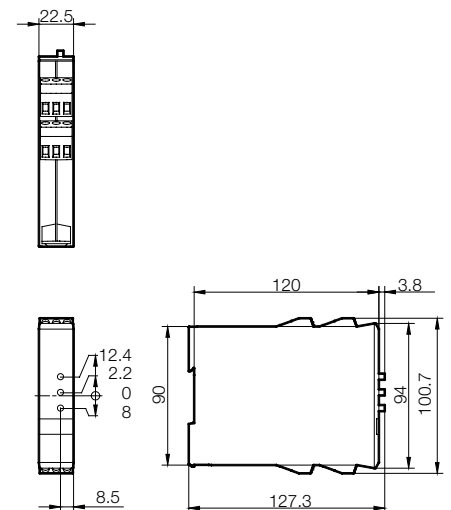


fig. 2. Dimension (mm)



Technical approvals, conformities

Standards IEC/EN 60947-4-2

Approvals

5.1 Softstarter

CCM3H415

3 phase | 400 V | 15 A | Starting Torque Limiter



Main circuit

Number of outputs	3
Controlled phases	2
Output type	⚡ Thyristor
Rated voltage	400 V
Output voltage range	400 ... 480 V AC
Reverse voltage	1200 V _{rrm}
Peak reverse voltage	1300 V _{rrm}
Rated current AC-53b	15 A
Minimum load	250 mA
Leakage current	5 mA
Inrush current	90 A
Rated limit load	1800 A [†]
Switching frequency (cycles / h)	3000

Control circuit

Nominal voltage	400 V AC
Ramp-up time	0.5 ... 10 s
Ramp-down time	0.5 ... 10 s
Torque adjustment	0 ... 85 %
Rated frequency	50 / 60 Hz

Insulation

Rated insulation voltage	660 V
Rated impulse withstand voltage open contact	4 kV / 1 min
Pollution degree	3
Overvoltage category	III

General data

Ambient temperature storage (no ice)	-20 ... 80 °C
Ambient temperature operation	-5 ... 40 °C
Ambient temperature operation derated power	-5 ... 60 °C
Conductor cross section control / main circuit	2.5 mm ² / 4 mm ²
Nominal screw torque control / main circuit	0.5 Nm / 1.2 Nm
Dimension	fig. 2
Weight	650 g
Protection degree	IP 20
Housing material	PPO
Mounting	TS 35 or Back Panel Mounting

Product references

Description	Type
Starting Torque Limiter, 3 phase	CCM3H415

Other devices on request. Please contact support@comatreleco.com.

Accessories

Thermal overload protection	P82-100C
-----------------------------	----------



fig. 1. Wiring diagram

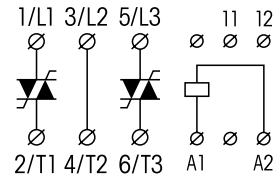
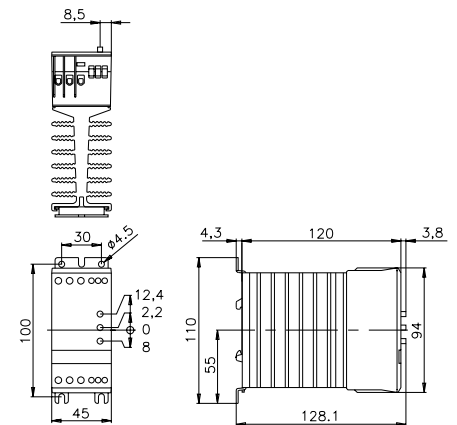


fig. 2. Dimension (mm)



Technical approvals, conformities

Standards IEC/EN 60947-4-2

Approvals

5.1 Softstarter

CCM3H415DS

3 phase | 400 V | 15 A | Starting Torque Limiter with direct switch

Main circuit

Number of outputs	3
Controlled phases	2
Output type	⚡ Thyristor
Rated voltage	400 V
Output voltage range	400 ... 480 V AC
Reverse voltage	1200 V _{rrm}
Peak reverse voltage	1300 V _{rrm}
Rated current AC-53b	15 A
Minimum load	250 mA
Leakage current	5 mA
Inrush current	90 A
Rated limit load	1800 A ² t
Switching frequency (cycles / h)	3000

Control circuit

Nominal voltage	400 V AC
Ramp-up time	N. A. (direct switch)
Ramp-down time	N. A. (direct switch)
Torque adjustment	N. A. (direct switch)
Rated frequency	50 / 60 Hz

Insulation

Rated insulation voltage	660 V
Rated impulse withstand voltage open contact	4 kV / 1 min
Pollution degree	3
Overvoltage category	III

General data

Ambient temperature storage (no ice)	-20 ... 80 °C
Ambient temperature operation	-5 ... 40 °C
Ambient temperature operation derated power	-5 ... 60 °C
Conductor cross section control / main circuit	2.5 mm ² / 4 mm ²
Nominal screw torque control / main circuit	0.5 Nm / 1.2 Nm
Dimension	fig. 2
Weight	650 g
Protection degree	IP 20
Housing material	PPO
Mounting	TS 35 or Back Panel Mounting

Product references

Description	Type
Starting Torque Limiter, 3 phase	CCM3H415DS

Other devices on request. Please contact support@comatreleco.com.

Accessories

Thermal overload protection	P82-100C
-----------------------------	----------



fig. 1. Wiring diagram

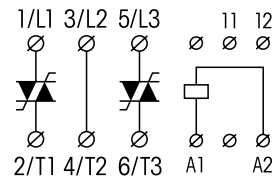
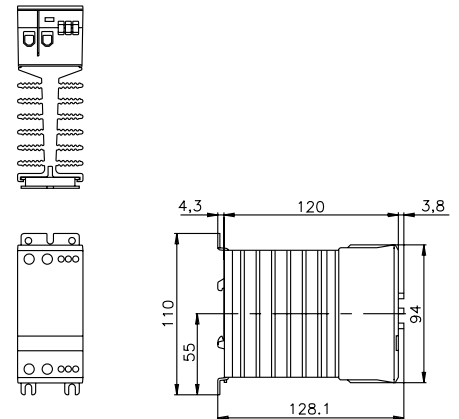


fig. 2. Dimension (mm)



Technical approvals, conformities

Standards IEC/EN 60947-4-2

Approvals  

5.1 Softstarter

CCM3H425

3 phase | 400 V | 25 A | Starting Torque Limiter

Main circuit

Number of outputs	3
Controlled phases	2
Output type	⚡ Thyristor
Rated voltage	400 V
Output voltage range	400 ... 480 V AC
Reverse voltage	1200 V _{rrm}
Peak reverse voltage	1300 V _{rrm}
Rated current AC-53b	25 A
Minimum load	250 mA
Leakage current	5 mA
Inrush current	150 A
Rated limit load	6300 A ²
Switching frequency (cycles / h)	3000

Control circuit

Nominal voltage	400 V AC
Ramp-up time	0.5 ... 10 s
Ramp-down time	0.5 ... 10 s
Torque adjustment	0 ... 85 %
Rated frequency	50 / 60 Hz

Insulation

Rated insulation voltage	660 V
Rated impulse withstand voltage open contact	4 kV / 1 min
Pollution degree	3
Overvoltage category	III

General data

Ambient temperature storage (no ice)	-20 ... 80 °C
Ambient temperature operation	-5 ... 40 °C
Ambient temperature operation derated power	-5 ... 60 °C
Conductor cross section control / main circuit	2.5 mm ² / 6 mm ²
Nominal screw torque control / main circuit	0.5 Nm / 1.2 Nm
Dimension	fig. 2
Weight	1050 g
Protection degree	IP 20
Housing material	PPO
Mounting	TS 35 or Back Panel Mounting

Product references

Description	Type
Starting Torque Limiter, 3 phase	CCM3H425

Other devices on request. Please contact support@comatreleco.com.

Accessories

Thermal overload protection	P82-100C
-----------------------------	----------



fig. 1. Wiring diagram

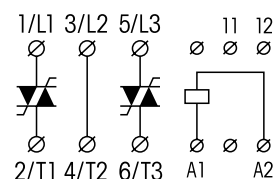
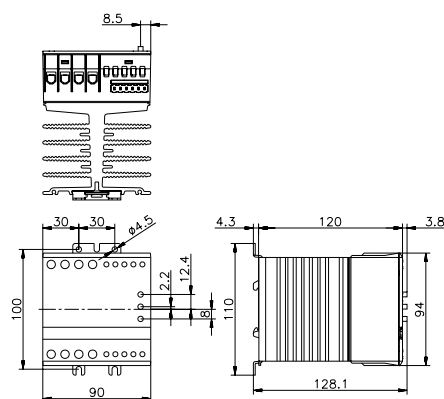


fig. 2. Dimension (mm)



Technical approvals, conformities

Standards IEC/EN 60947-4-2

Approvals

5.1 Softstarter

CCM33H450US

3 phase | 480 V | 50 A | Starting Torque Limiter

Main circuit

Number of outputs	3
Controlled phases	3
Output type	⚡ Thyristor
Bypass	Externally
Rated voltage	400 V
Output voltage range	200 ... 480 V AC
Reverse voltage	1200 V _{rrm}
Peak reverse voltage	1300 V _{rrm}
Rated current AC-53b	50 A
Minimum load	3 A
Leakage current	5 mA
Inrush current	300 A, 450 ms
Rated limit load	25300 A ² t
Switching frequency (cycles / h)	120

Control circuit

Nominal voltage	480 V AC
Operating voltage range	24 - 230 V UC
Release voltage	5 V UC
Ramp-up time	0.5 ... 30 s
Ramp-down time	0.5 ... 60 s
Torque adjustment	0 ... 85 %
Rated frequency	50 / 60 Hz

Insulation

Rated insulation voltage	660 V
Rated impulse withstand voltage open contact	4 kV / 1 min
Pollution degree	3
Overvoltage category	III

General data

Ambient temperature storage (no ice)	-20 ... 80 °C
Ambient temperature operation	-5 ... 40 °C
Ambient temperature operation derated power	-5 ... 60 °C
Conductor cross section control / main circuit	2.5 mm ² / 6 mm ²
Nominal screw torque control / main circuit	0.5 Nm / 1.2 Nm
Dimension	fig. 2
Weight	2500 g
Protection degree	IP 20
Housing material	PPE
Mounting	TS 35 or Back Panel Mounting

Product references

Description	Type
Starting Torque Limiter, 3 phase	CCM33H450US

Other devices on request. Please contact support@comatreleco.com.

Accessories

Thermal overload protection	P82-100C
-----------------------------	----------



fig. 1. Wiring diagram

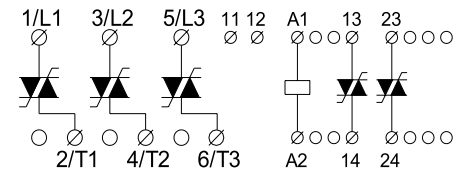
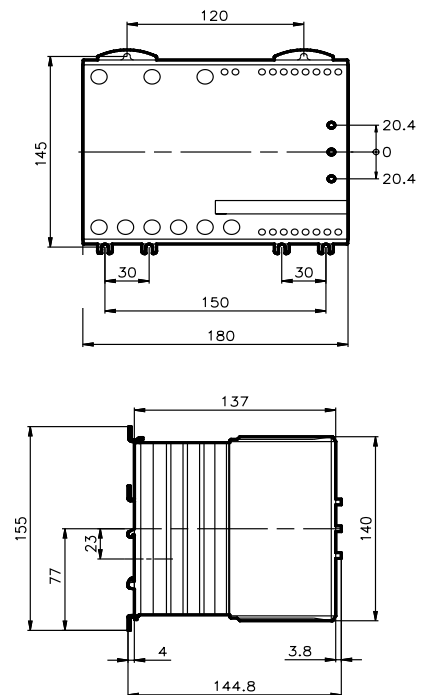


fig. 2. Dimension (mm)



Technical approvals, conformities

Standards IEC/EN 60947-4-2

Approvals

5.1 Softstarter

CCM33H530USi

3 phase | 480 V | 30 A | Starting Torque Limiter



Main circuit

Number of outputs	3
Controlled phases	3
Output type	⚡ Thyristor
Bypass	Externally
Rated voltage	400 V
Output voltage range	200 ... 480 V AC
Reverse voltage	1200 V _{rrm}
Peak reverse voltage	1300 V _{rrm}
Rated current AC-53b	30 A
Minimum load	3 A
Leakage current	5 mA
Inrush current	180 A, 450 ms
Rated limit load	6300 A ^t
Switching frequency (cycles / h)	120

Control circuit

Nominal voltage	480 V AC
Operating voltage range	24 - 230 V UC
Release voltage	5 V UC
Ramp-up time	0.5 ... 30 s
Ramp-down time	0.5 ... 60 s
Torque adjustment	0 ... 85 %
Rated frequency	50 / 60 Hz

Insulation

Rated insulation voltage	660 V
Rated impulse withstand voltage open contact	4 kV / 1 min
Pollution degree	3
Overtoltage category	III

General data

Ambient temperature storage (no ice)	-20 ... 80 °C
Ambient temperature operation	-5 ... 40 °C
Ambient temperature operation derated power	-5 ... 60 °C
Conductor cross section control / main circuit	2.5 mm ² / 6 mm ²
Nominal screw torque control / main circuit	0.5 Nm / 1.2 Nm
Dimension	fig. 2
Weight	1050 g
Protection degree	IP 20
Housing material	PPE
Mounting	TS 35 or Back Panel Mounting

Product references

Description	Type
Starting Torque Limiter, 3 phase	CCM33H530USi

Other devices on request. Please contact support@comatreleco.com.

Accessories

Thermal overload protection	P82-100C
-----------------------------	----------



fig. 1. Wiring diagram

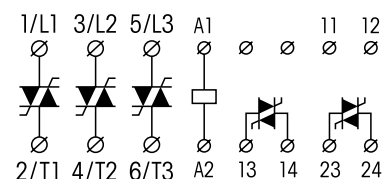
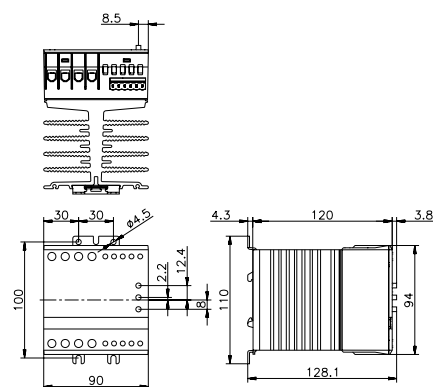


fig. 2. Dimension (mm)



Technical approvals, conformities

Standards IEC/EN 60947-4-2

Approvals

5.1 Softstarter

CCM33H550USi

3 phase | 480 V | 50 A | Starting Torque Limiter

Main circuit

Number of outputs	3
Controlled phases	3
Output type	⚡ Thyristor
Bypass	Externally
Rated voltage	400 V
Output voltage range	200 ... 480 V AC
Reverse voltage	1200 V _{rrm}
Peak reverse voltage	1300 V _{rrm}
Rated current AC-53b	50 A
Minimum load	3 A
Leakage current	5 mA
Inrush current	300 A, 450 ms
Rated limit load	25300 A ² t
Switching frequency (cycles / h)	120

Control circuit

Nominal voltage	480 V AC
Operating voltage range	24 - 230 V UC
Release voltage	5 V UC
Ramp-up time	0.5 ... 30 s
Ramp-down time	0.5 ... 60 s
Torque adjustment	0 ... 85 %
Rated frequency	50 / 60 Hz

Insulation

Rated insulation voltage	660 V
Rated impulse withstand voltage open contact	4 kV / 1 min
Pollution degree	3
Overvoltage category	III

General data

Ambient temperature storage (no ice)	-20 ... 80 °C
Ambient temperature operation	-5 ... 40 °C
Ambient temperature operation derated power	-5 ... 60 °C
Conductor cross section control / main circuit	2.5 mm ² / 6 mm ²
Nominal screw torque control / main circuit	0.5 Nm / 1.2 Nm
Dimension	fig. 2
Weight	2500 g
Protection degree	IP 20
Housing material	PPE
Mounting	TS 35 or Back Panel Mounting

Product references

Description	Type
Starting Torque Limiter, 3 phase	CCM33H550USi

Other devices on request. Please contact support@comatreleco.com.

Accessories

Thermal overload protection	P82-100C
-----------------------------	----------



fig. 1. Wiring diagram

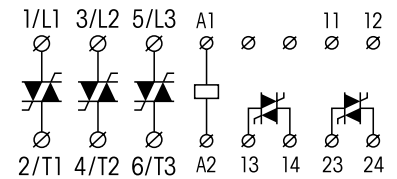
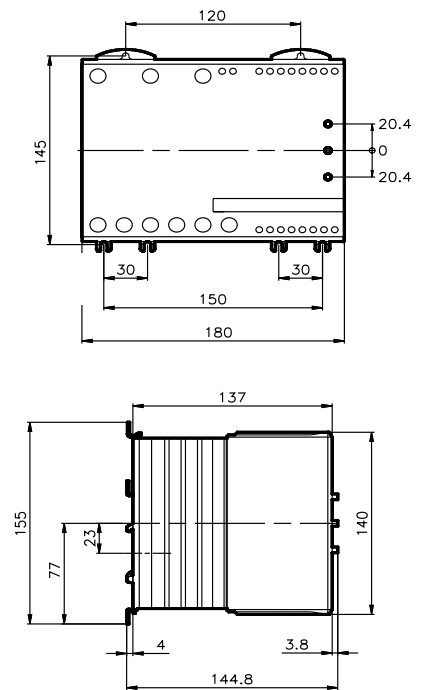


fig. 2. Dimension (mm)



Technical approvals, conformities

Standards IEC/EN 60947-4-2

Approvals

5.1 Softstarter CCMB3H425

3 phase | 400 V | 25 A | Starting Torque Limiter with dynamic brake



Main circuit

Number of outputs	3
Controlled phases	2
Output type	⚡ Thyristor
Bypass	Externally
Rated voltage	400 V
Output voltage range	400 ... 480 V AC
Reverse voltage	1600 Vrrm
Peak reverse voltage	1650 Vrrm
Rated current AC-53a	25 A
Minimum load	1 A
Leakage current	5 mA
Inrush current	200 A
Rated limit load	6300 A ^t

Control circuit

Nominal voltage	480 V AC
Operating voltage range	24 - 230 V UC
Release voltage	5 V UC
Pick-up time	100 ms
Release time	100 ms
Ramp-up time	0.5 ... 10 s
Brake current	0 ... 50 A
Torque adjustment	0 ... 85 %
Rated frequency	50 / 60 Hz
Pollution degree	3
Overvoltage category	III

General data

Ambient temperature storage (no ice)	-20 ... 80 °C
Ambient temperature operation	-5 ... 40 °C
Ambient temperature operation derated power	-5 ... 60 °C
Conductor cross section control / main circuit	2.5 mm ² / 6 mm ²
Dimension	fig. 2
Weight	1050 g
Protection degree	IP 20
Housing material	PPE
Mounting	TS 35 or Back Panel Mounting

Product references

Description	Type
Starting Torque Limiter with dynamic brake, 3 phase	CCMB3H425

Accessories

Thermal overload protection	P82-100C
-----------------------------	----------



fig. 1. Wiring diagram

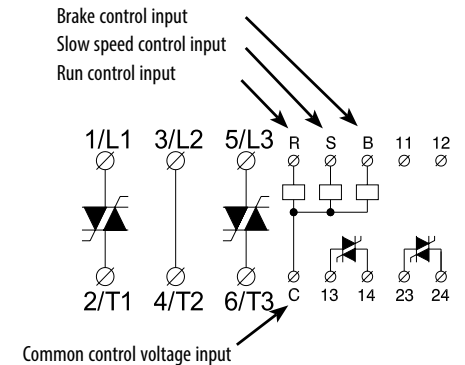
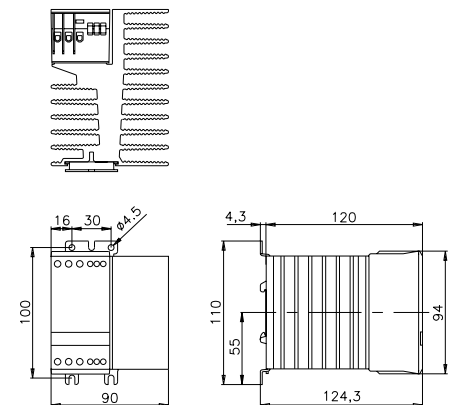


fig. 2. Dimension (mm)



Technical approvals, conformities

Standards IEC/EN 60947-4-2

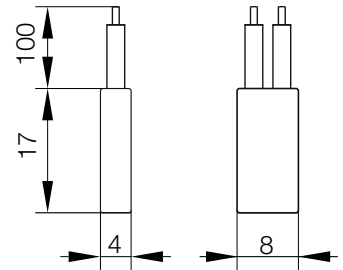
Approvals

P82-100C**Thermal overload protection****General data**

Dimension	fig. 1
Weight	3 g
Protection degree	IP 66
Mounting	Slot on contactor

Product references

Description	Type
Thermal overload protection	P82-100C

**fig. 1. Dimension (mm)**

5.2 DC Motor Controller

	Type	Page
CMC Series		
DC motor controller digital inputs constant speed	CMC1	120
DC motor controller variable speed	CMC14	121
DC motor controller analogue inputs 0 ... 10 V variable speed	CMC15	122
DC motor controller analogue inputs 4 ... 20 mA variable speed	CMC16	123
KDM Series		
DC motor relay 1 output for motor 1 output for breaking resistor faston	KDM3-24	124

CMC1

DC motor controller | digital inputs | constant speed



Power supply

Nominal voltage	12 ... 24 V DC
Operating voltage range	8 ... 28 V DC
Maximum current consumption without load	10 mA
Power consumption 12 V DC	120 mW
Power consumption 24 V DC	240 mW

Main circuit

Output type	MOSFET H bridge
Rated voltage	24 V DC
Output voltage range	8 ... 28 V DC
Rated current	16 A
Maximum inrush current	20 A, 3 s
Rated limit load DC-5	384 W

Control circuit

Nominal voltage	12 ... 24 V DC
Operating voltage range	8 ... 28 V DC
Ramp up	0 ... 4 s
Ramp down	0 ... 4 s
Current consumption 12 V DC	3 mA
Current consumption 24 V DC	6 mA

General data

Ambient temperatur storage (no ice)	-40 ... 85 °C
Ambient temperatur operation	-25 ... 60 °C
Nominal screw torque control	2.5 mm ²
Dimension	fig. 3.
Weight	80 g
Protection degree	IP 20
Housing material	Aluminium
Mounting	TS-35 or back panel mounting

Product reference

Description	Type	12-24
DC	CMC1/DC...V	✓

Other voltages on request. Please contact support@comatreleco.com.

«...» List coil voltage to complete product references

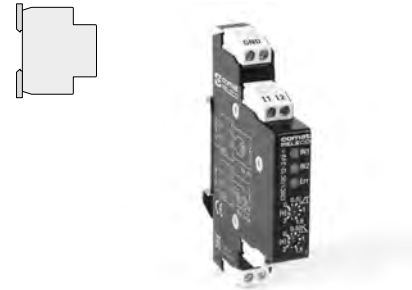


fig. 1. Wiring diagram

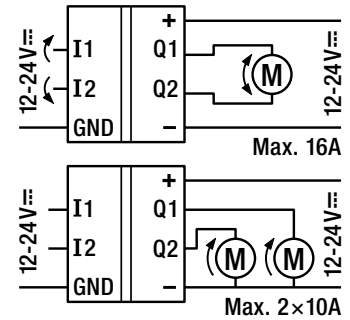


fig. 2. Function diagram

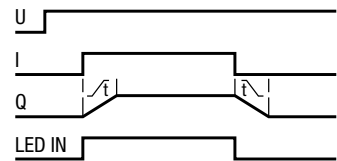
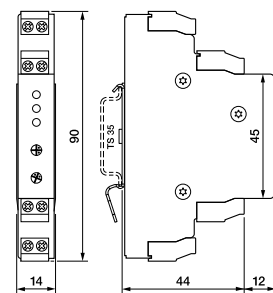


fig. 3. Dimension (mm)



Standards and approvals

Standards EN 61000-6; EN 61000-4; EN 55022; EN 60730-1

Approvals

CMC14

DC motor controller | variable speed

Power supply

Nominal voltage	12 ... 24 V DC
Operating voltage range	8 ... 28 V DC
Maximum current consumption without load	10 mA
Power consumption 12 V DC	120 mW
Power consumption 24 V DC	240 mW

Main circuit

Output type	⚡ MOSFET H bridge
Rated voltage	24 V DC
Output voltage range	8 ... 28 V DC
Rated current	10 A
Maximum inrush current	20 A, 3 s
Rated limit load DC-5	240 W

Control circuit

Nominal voltage	12 ... 24 V DC
Operating voltage range	8 ... 28 V DC
Ramp up	0 ... 4 s
Ramp down	0 ... 4 s
Current consumption 12 V DC	3 mA
Current consumption 24 V DC	6 mA

General data

Ambient temperatur storage (no ice)	-40 ... 85 °C
Ambient temperatur operation	-25 ... 70 °C
Nominal screw torque control	2.5 mm ²
Dimension	fig. 3.
Weight	80 g
Protection degree	IP 20
Housing material	Aluminium
Mounting	TS-35 or back panel mounting

Product reference

Description	Type	12-24
DC	CMC14/DC...V	✓

Other voltages on request. Please contact support@comatreleco.com.

«...» List coil voltage to complete product references

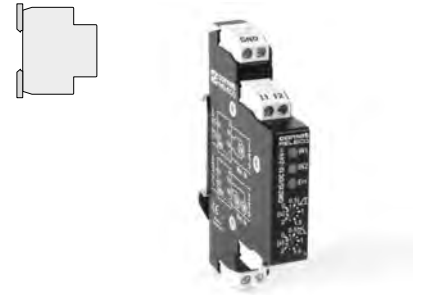


fig. 1. Wiring diagram

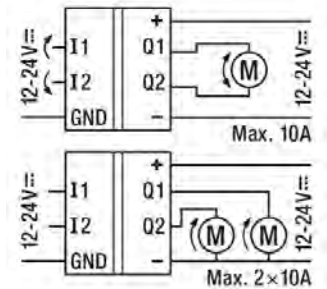


fig. 2. Function diagram

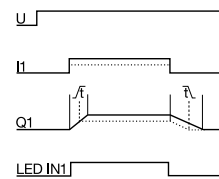
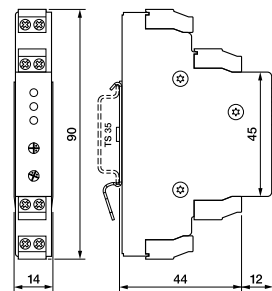


fig. 3. Dimension (mm)



Standards and approvals

Standards EN 61000-6; EN 61000-4; EN 55022; EN 60730-1

Approvals

CMC15

DC motor controller | analogue inputs 0 ... 10 V | variable speed



Power supply

Nominal voltage	12 ... 24 V DC
Operating voltage range	8 ... 28 V DC
Maximum current consumption without load	10 mA
Power consumption 12 V DC	120 mW
Power consumption 24 V DC	240 mW

Main circuit

Output type	MOSFET H bridge
Rated voltage	24 V DC
Output voltage range	8 ... 28 V DC
Rated current	10 A
Maximum inrush current	20 A, 3 s
Rated limit load DC-5	240 W

Control circuit

Nominal operating voltage range	0 ... 10 V DC
Ramp up	0 ... 2 s
Ramp down	0 ... 2 s
Resolution	8 Bit
Input impedance	55 kΩ

General data

Ambient temperatur storage (no ice)	-40 ... 85 °C
Ambient temperatur operation	-25 ... 70 °C
Nominal screw torque control	2.5 mm ²
Dimension	fig. 3.
Weight	80 g
Protection degree	IP 20
Housing material	Aluminium
Mounting	TS-35 or back panel mounting

Product reference

Description	Type	12-24
DC	CMC15/DC...V	✓

Other voltages on request. Please contact support@comatreleco.com.

«...» List coil voltage to complete product references

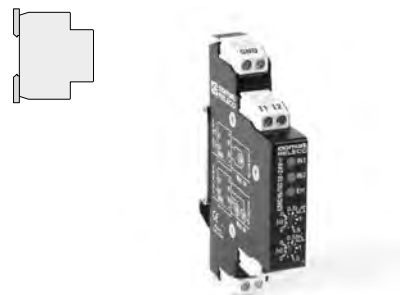


fig. 1. Wiring diagram

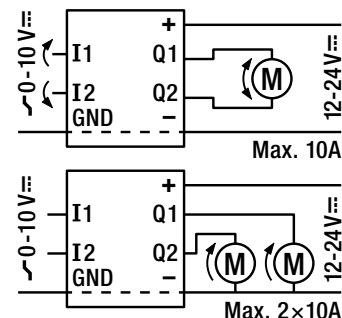


fig. 2. Function diagram

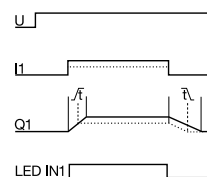
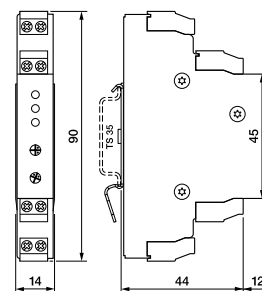


fig. 3. Dimension (mm)



Standards and approvals

Standards EN 61000-6; EN 61000-4; EN 55022; EN 60730-1

Approvals

CMC16**DC motor controller | analogue inputs 4 ... 20 mA | variable speed****Power supply**

Nominal voltage	12 ... 24 V DC
Operating voltage range	8 ... 28 V DC
Maximum current consumption without load	10 mA
Power consumption 12 V DC	120 mW
Power consumption 24 V DC	240 mW

Main circuit

Output type	⚡ MOSFET H bridge
Rated voltage	24 V DC
Output voltage range	8 ... 28 V DC
Rated current	10 A
Maximum inrush current	20 A, 3 s
Rated limit load DC-5	240 W

Control circuit

Nominal operating current range	4 ... 20 A
Ramp up	0 ... 2 s
Ramp down	0 ... 2 s
Resolution	8 Bit
Input impedance	190 Ω

General data

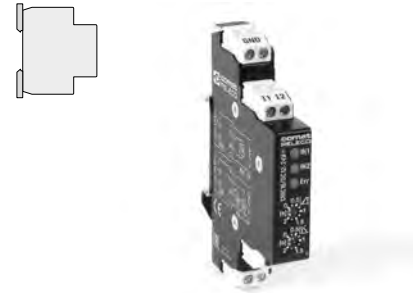
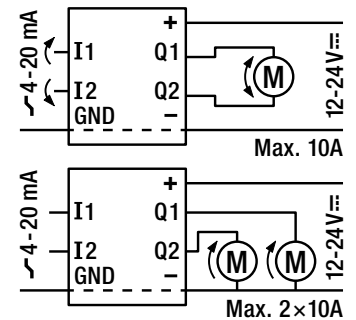
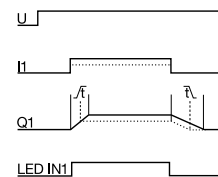
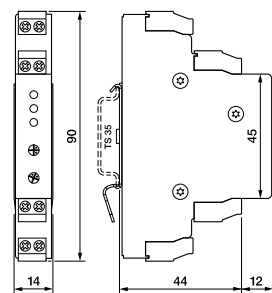
Ambient temperatur storage (no ice)	-40 ... 85 °C
Ambient temperatur operation	-25 ... 70 °C
Nominal screw torque control	2.5 mm ²
Dimension	fig. 3.
Weight	80 g
Protection degree	IP 20
Housing material	Aluminium
Mounting	TS-35 or back panel mounting

Product reference

Description	Type	12-24
DC	CMC16/DC...V	✓

Other voltages on request. Please contact support@comatreleco.com.

«...» List coil voltage to complete product references

**fig. 1. Wiring diagram****fig. 2. Function diagram****fig. 3. Dimension (mm)****Standards and approvals**

Standards EN 61000-6; EN 61000-4; EN 55022;
EN 60730-1

Approvals

KDM3-24



DC motor relay | 1 output for motor | 1 output for braking resistor | faston

Power supply

Nominal voltage	12 ... 24 V DC
Operating voltage range	9 ... 28 V DC
Power consumption 12 V DC	36 mW
Power consumption 24 V DC	24 mW

Main circuit

Output type	FET PNP
Output voltage range	10 ... 32 V DC
Rated current	3 A
Maximum inrush current	20 A, 1 s

Control circuit

Nominal operating current range	3 mA @ 12 V DC / 10 mA @ 24 V DC
---------------------------------	----------------------------------

General data

Ambient temperatur storage (no ice)	-40 ... 85 °C
Ambient temperatur operation	-25 ... 60 °C
Dimension	fig. 4.
Weight	27 g
Protection degree	IP 40
Housing material	Noryl
Mounting	Faston

Product reference

Description	Type	12-24
DC	KDM3-24/DC...V R	✓

Other voltages on request. Please contact support@comatreleco.com.

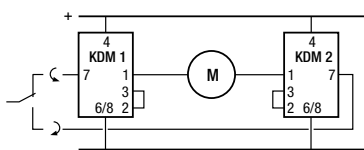
«...» List coil voltage to complete product references

Accessories

Socket	S7-C
--------	------

Application example

Four quadrant (forward / reversed) motor control



Operating with brake resistors (on 2-3) is not recommended in this application.



fig. 1. Wiring diagram

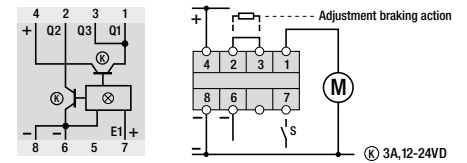


fig. 2. Function diagram

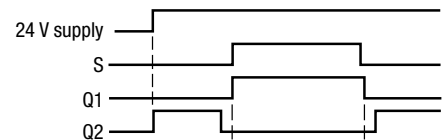


fig. 3. Output current vs. duty cycle

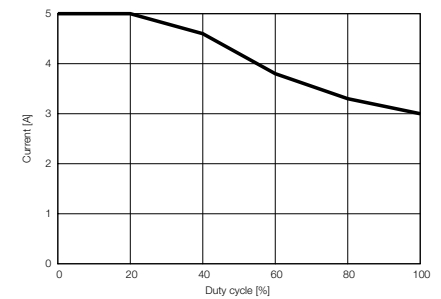
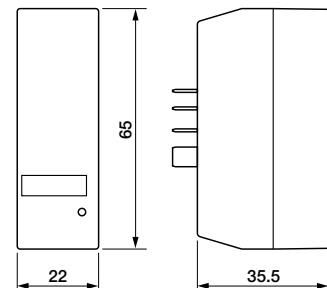


fig. 4. Dimension (mm)

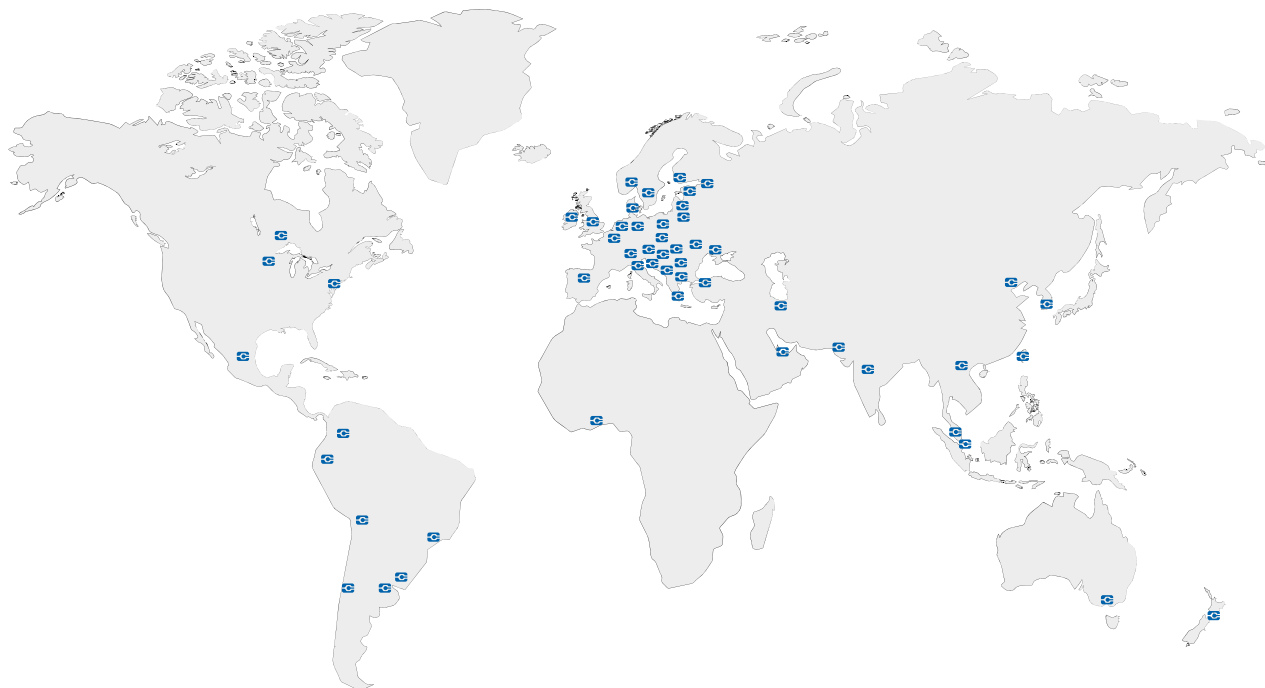


Standards and approvals

Standards EN 50081-1; EN 50082-2;
IEC/EN 61000-4-5

Approvals

8 Worldwide Sales Network



ASIA

CHINA

ELCO (TIANJIN) ELECTRONICS CO., LTD.
www.elco-holding.com



SINGAPORE

FUTRON ELECTRONICS PTE. LTD.
www.futronelectronics.com.sg



THAILAND

538 CO., LTD.
538LTD@gmail.com



INDIA

CONCORD AUTOMATION & CONTROLS
www.cacindia.net



SOUTH KOREA

MAHANI ELECTRIC CO., LTD.
www.mec.co.kr



SRINUTCH COMPONENTS CO., LTD.
www.srinutch.com

MALAYSIA

ELECTRICAL MARKETING SDN. BHD
emsb@tm.net.my



TAIWAN

Z-NANOCON & AUTOMATION INT'L CORP
www.e-sensors.com.tw



VIETNAM

PLC PRODUCTION AND TRADE COMPANY LIMITED
plchanoi@gmail.com



OCEANIA

AUSTRALIA

ARLIN PTY LTD.
www.arlin.com.au



NEW ZEALAND

CUTHBERT STEWART LTD.
www.cuthbertstewart.co.nz



EUROPE

<p>AUSTRIA TURCK GmbH www.turck.at</p> 	<p>GREAT BRITAIN CAMIS ELECTRONICS LTD. www.camiselectronicssuk.com</p> 	<p>REPUBLIC OF MACEDONIA TIPTEH SKOPJE D.O.O. www.tipteh.mk</p> 
<p>BELGIUM TURCK MULTIPROX N.V. www.multiprox.be</p> 	<p>OEM AUTOMATIC LTD. www.oem.co.uk</p>	<p>RUSSIA POLIGON LTD. www.poligon.info</p> 
<p>BOSNIA AND HERZEGOVINA TIPTEH D.O.O. www.tipteh.ba</p> 	<p>GREECE MEGA EL. (VASSILIS GETSOS A.) www.megael.gr</p> 	<p>SERBIA TIPTEH D.O.O. BEOGRAD www.tipteh.rs</p> 
<p>BULGARIA SENSOMAT LTD. www.sensomat.info</p> 	<p>HUNGARY OEM AUTOMATIC KFT. www.oemautomatic.hu</p> 	<p>SLOVAKIA MARPEX, S.R.O. www.marplex.sk</p> 
<p>CROATIA TIPTEH ZAGREB D.O.O. www.tipteh.hr</p> 	<p>IRELAND TCM CONTROLS LTD. www.tcmcontrols.com</p> 	<p>OEM AUTOMATIC, S.R.O. www.oem.sk</p>
<p>CZECH REPUBLIC OEM AUTOMATIC, SPOL. S.R.O. www.oem-automatic.cz</p> 	<p>ITALY S.P.I.I. S.P.A. www.sp.ii.it</p> 	<p>SLOVENIA TIPTEH D.O.O. www.tipteh.si</p> 
<p>DENMARK OEM AUTOMATIC, SPOL. S.R.O. www.oem-automatic.cz</p> 	<p>LITHUANIA HIDROTEKA ENGINEERING SERVICES www.hidroteka.lt</p> 	<p>SPAIN DISAILECO, SL www.disaileco.com</p> 
<p>ESTONIA OEM EESTI OÜ www.oem.ee</p> 	<p>LATVIA OEM AUTOMATIC UAB www.oem.ee</p> 	<p>SWEDEN BEVING ELEKTRONIK AB www.beving.se</p> 
<p>FRANCE COMATRELECO AG www.comatreleco.com</p> 	<p>NETHERLANDS VIERPOOL BV. www.vierpool.nl</p> 	<p>SWITZERLAND COMATRELECO AG www.comatreleco.com</p> 
<p>FINLAND OEM FINLAND OY www.oem.fi</p> 	<p>NORWAY OEM AUTOMATIC AS www.oem.no</p> 	<p>TURKEY DESA REPRESENTATION & CONSULTANCY & ENGINEERING LTD. www.desa-trade.com</p> 
<p>GERMANY COMAT RELECO GMBH www.comatreleco.de</p> 	<p>POLAND ANIM SPÓLKA Z OGRANICZONA ODPOWIEDZIALNOSCIA SP.K. www.anim.com.pl</p> 	<p>ILERI OTOMASYON SISTEMLERI SAN. LTD. STI. www.ileriotomasyon.com</p>
<p>UKRAINE SENSORLINK UA LLC www.sensorlink.com.ua</p> 	<p>ASTAT LOGISTYKA SP. Z O.O. www.astat.com.pl</p> <p>OEM AUTOMATIC SP. Z O.O. www.oemautomatic.com.pl</p>	

AFRICA

<p>NIGERIA PANEK GLOBAL SERVICES LTD. www.panekglobal.com/</p> 

NORTH & CENTRAL AMERICA

CANADA
TURCK CANADA INC.
www.turck.ca



MEXICO
TURCK MEXICO S. DE R.L.DE C.V.
www.turck.com.mx



UNITED STATES
ELECTROTECH SALES GROUP LLC
www.esgllc-usa.com

TURCK INC.
www.turck.us



SOUTH AMERICA

ARGENTINA
WINTERS INSTRUMENTS S.A.
www.winters.com.ar



CHILE
RHOMBERG LTDA.
www.rhomberg.cl



URUGUAY
ELEKTROSWEDEN S.A.
www.elektrosveden.com.uy



BOLIVIA
LEVCORP S.A.
www.levcorp.bo



COLOMBIA
ACJ HIGH VOLTAGE LTDA.
www.acj.com.co



BRAZIL
COMAT RELECO DO BRASIL
www.comatreleco.com.br



ECUADOR
IANDCECONTROL, S.A.
www.iandcecontrol.com



MIDDLE EAST

IRAN
DANESH ENERGY SARIR CO.
www.desc-co.com



PAKISTAN
GINZA INTERNATIONAL CORPORATION
Ginza-int@cyber.net.pk



UAE
ZANTRA MARINE EQUIPMENT LLC
www.zantra-marine.com



WORLD OF RELAYS

ComatReleco AG

Bernstrasse 4 | 3076 Worb | Switzerland

Tel. +41 31 838 55 77

Fax +41 31 838 55 99

info@comatreleco.com | comatreleco.com

support@comatreleco.com | WorldofRelays.com