

Product Datasheet

Product Name : Circuit Breaker for Equipment

Models : NDB3-30

Date : 20181030

Made	Checked	Approved
Kang Fan	Zhang Jian	Duan Hui

	File name	Product specification	File number	NDT500478
	Product Name	NDB3-30 Circuit breaker for equipment	Version	5 version
			Date	20181030

Revision

Version	Revised contents and reasons	Date	Revision
0	First edition publication	20130603	ZHANGmei
1	Add integrated terminal product	20160510	TENGjianbin
2	Change "Special function code"	20170620	Zhang Jian
3	Add"DC65V" voltage	20180619	Kang Fan
4	Terminal dimensions add thickness size	20181010	Kang Fan
5	Unified updated version according to the requirements of company	20181030	Kang Fan

File number	NDT500478	Version	5 version	Date	20181030
-------------	-----------	---------	-----------	------	----------

1 Application

NDB3-30 series circuit breaker for equipment (hydraulic-magnetic circuit breaker) is used in the power system with rated current from 0.1A to 30A, rated voltage up to AC250V (50/60Hz) or DC80V. It provides overload, short circuit protection. It can also be used for infrequent close or open. The application fields are computer and peripheral equipment, industrial automatic control system, telecom equipment, power supply system, UPS, railroad, marine, spacecraft, elevator, portable power supply and so on.

2 Model and Implication

ND B 3 - 30 Z4 20 / 2 Q H Y1 - 2 - 0 - R
 1 2 3 4 5 6 7 8 9 10 11 12 13

XXXXX

14

No.	Implication	NDB3-30
1	Brand code	ND "Nader" brand
2	Product code	B Circuit Breaker for Equipment
3	Design code	3
4	Frame size	30
5	Tripping curve	Z2 DC short delay Z4 DC medium delay J2 AC short delay J4 AC medium delay
6	Rated current of standard CBE (A)	0.1, 0.2, 0.3, 0.4, 0.5, 0.6, 0.7, 0.75, 0.8, 0.9, 1, 1.5, 2, 2.5, 3, 3.5, 4, 4.5, 5, 5.5, 6, 6.5, 7, 7.5, 8, 8.5, 9, 9.5, 10, 11, 12, 13, 14, 15, 16, 17, 18, 19, 20, 21, 22, 23, 24, 25, 26, 27, 28, 29, 30
	Rated current of lightning protection CBE (A)	10, 11, 12, 13, 14, 15, 16, 17, 18, 19, 20, 21, 22, 23, 24, 25, 26, 27, 28, 29, 30
7	Number of poles	1 One pole 2 Two poles
8	Mounting method	Q Snap-in mounting
9	Wiring method	H Solder-in /Q.C. tab type C Push-in stud
		E Screw 8-32UNC type J Screw 8-32UNC with upturned lugs
		P Screw M4 type R Screw M4 with upturned lugs
10	Actuator type code	Y1 Black rocker, vertical white legend Y2 Black rocker, horizontal white legend
		Y3 White rocker, vertical black legend Y4 White rocker, horizontal black legend
		Y5 Orange rocker, vertical black legend Y6 Orange rocker, horizontal black legend
		Y7 Red rocker, vertical black legend Y8 Red rocker, horizontal black legend
11	Case color code	1 Black 2 Gray
		3 Black without rocker guard
		4 Gray without rocker guard
12	Accessory code	0 No accessory
13	Certificate code	No code TUV, CE, CCC
		R UL1077, TUV, CE, CCC
		L UL489A listed, TUV, CE, CCC
14	Customer code	Customer code (Additional option)

File number	NDT500478	Version	5 version	Date	20181030
-------------	-----------	---------	-----------	------	----------

Note: Illustration of the actuator type

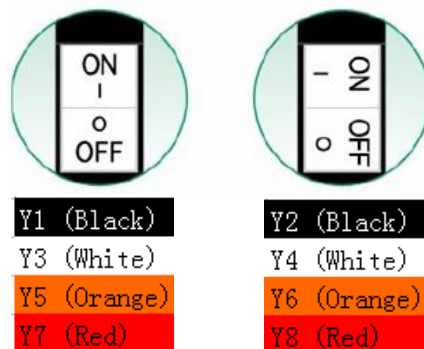

3 Specification

- 3.1 Standards: IEC 60934, GB/T 17701, UL1077, UL489A
- 3.2 Rated working voltage (Ue): AC250V(50/60Hz), DC80V, DC65V
- 3.3 Power frequency withstand voltage: 2500V (The withstand voltage of products using in altitude of 4000m is tested under 2500V*1.29 at sea level in the factory.)
- 3.4 Mechanical/Electrical endurance: 10000/6000 times
- 3.5 Tripping model: Hydraulic-magnetic type
- 3.6 Trip-free feature: with trip-free mechanism
- 3.7 Vibration and shock parameters (w/o loads)
 Vibration test parameter: sweep frequency 8Hz~500Hz~8Hz within sine wave, accelerated speed is 3g.
 Shock test parameters: shock pulse period is 30ms, shock is 30g.

3.8 Rated breaking capacity (Icn):

Rated voltage (V)	Frequency	Rated current (A)	Number of poles	Breaking capacity (A)					
				3C(GB/T 17701)		UL1077	UL489A	TUV/CE(EN60934)	
				Inc	Icn			Inc	Icn
AC250V	50/60Hz	0.1-30	1, 2	1500	1000	1000, U1	/	1500	1000
DC80V	/	0.1-30	1, 2	1000	600	1000, U1	/	1000	600
DC65V	/	1-30	1,2	/	1000	/	/	/	/
DC80V	/	0.1-30	1	/	/	/	600	/	/
DC65V	/	0.1-30	1	/	/	/	1000	/	/

4 Working conditions

- 4.1 Operation temperature: -40°C~+85°C
- 4.2 Altitude: ≤2000m
- 4.3 Humidity: ≤95%
- 4.4 Service place without explosive media, gas and dust which are corrosive and conductive.
- 4.5 Be mounted free from rain and snow.

File number	NDT500478	Version	5 version	Date	20181030
-------------	-----------	---------	-----------	------	----------

5 Tripping characteristic

5.1 Tripping timetable (in seconds)

Current Curves	In	135% In	200% In	600% In	1000% In
Z2/J2	No trip	0.3-7	0.1-2	0.008-0.3	0.005-0.1
Z4/J4	No trip	3-70	1-15	0.008-2	0.005-0.35

5.2 Tripping curves

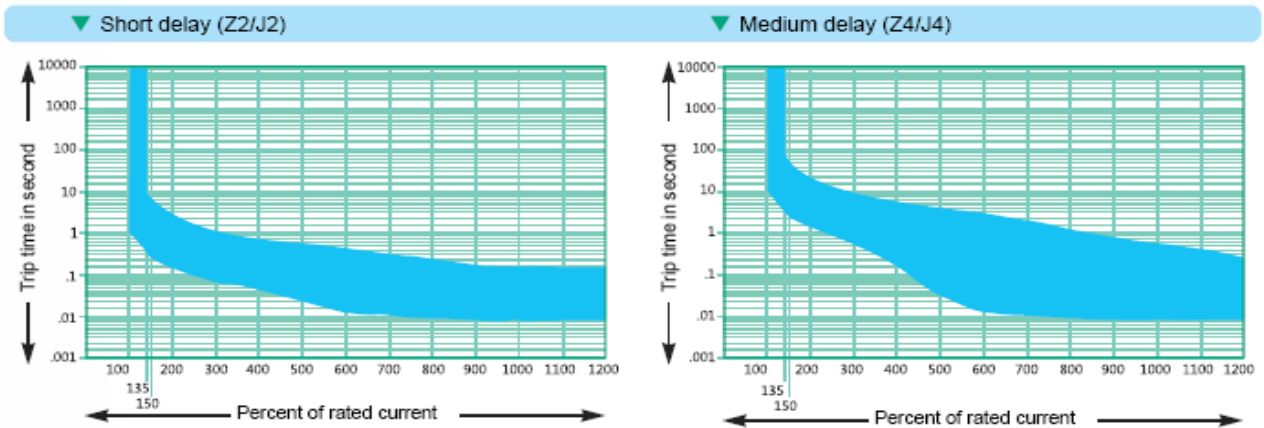

6 Dimensions and wiring method

6.1 Outline dimensions

6.1.1 Single-pole product

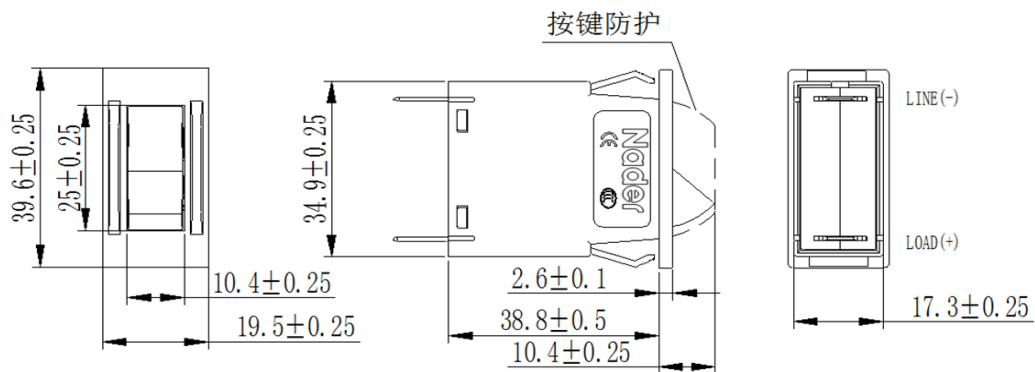

6.1.2 Two-pole product

File number	NDT500478	Version	5 version	Date	20181030
-------------	-----------	---------	-----------	------	----------

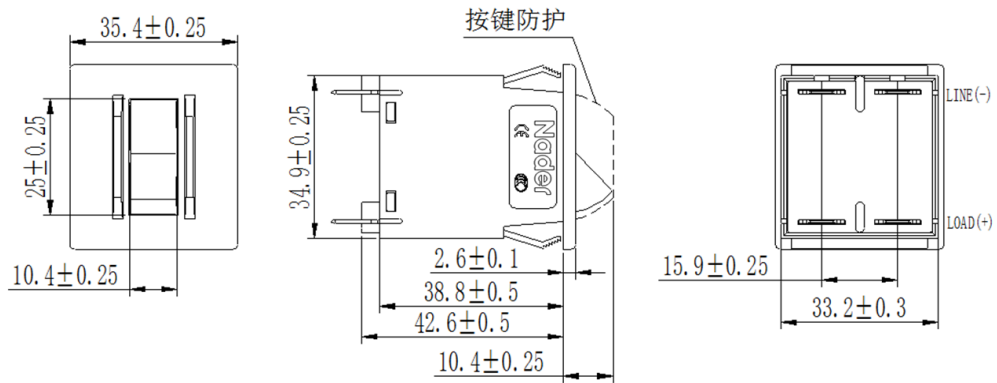

6.2 Terminal dimensions

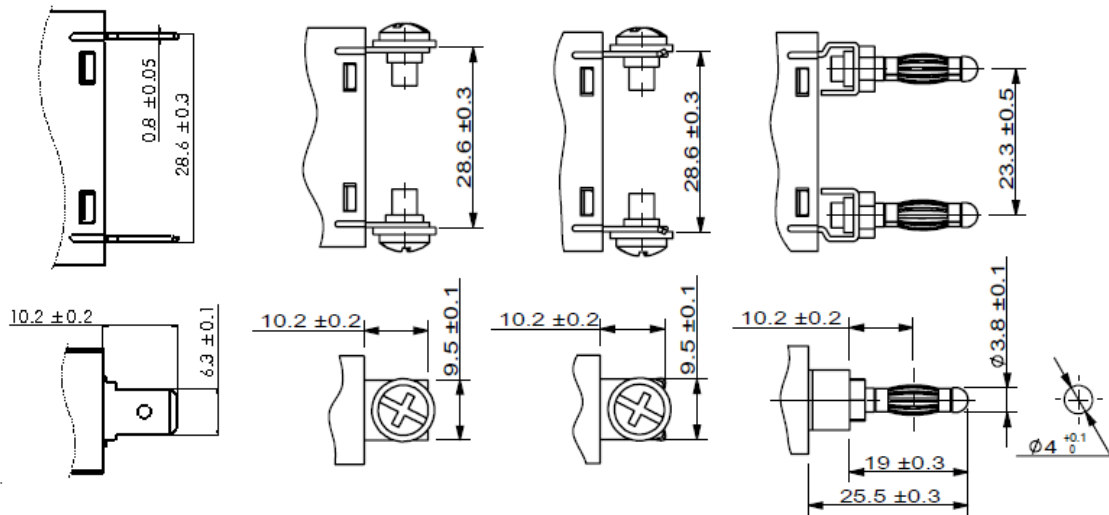

Solder-in /Q.C. tab type

Screw type

Screw with upturned lugs

Push-in stud

Note: 1. During wiring, applied torque on M4 or 8-32UNC screw is 1.2 N.m, applied torque on M5 is 2 N.m,

7 Wiring method and dimension

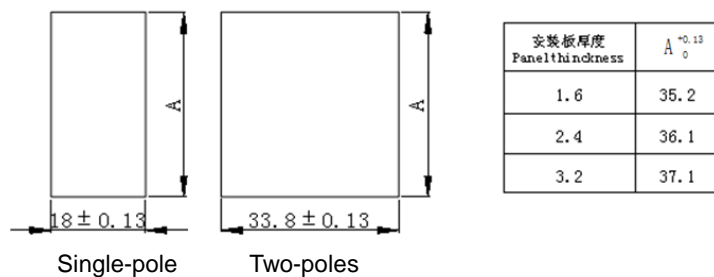

File number	NDT500478	Version	5 version	Date	20181030
-------------	-----------	---------	-----------	------	----------

8 Wiring diagrams

Since the arc-extinguish theory of the DC NDB3 series circuit breaker relates to the circuit direction, wiring should follow up '+' and '-' on the products if there are. Otherwise the circuit breaker might be burnt up.

Wiring diagrams are showing below:

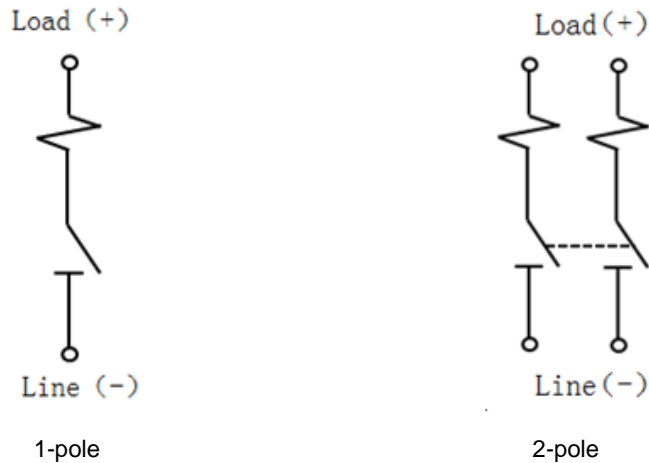

9 Packing and depositing

9.1 Minimum packing quantity:

1-pole: 18 pieces in a box, 12 boxes in an overwrap carton.

1-pole (Integrated terminal product): 12 pieces in a box, 12 boxes in an overwrap carton

2-pole: 12 pieces in a box, 12 boxes in an overwrap carton.

9.2 The products should be stored in the warehouse where there is ventilation. The relative humidity there should not exceed 80%, and the ambient temperature there is between -25°C to +60°C. In addition, there should not be acidic, alkaline and corrosive gas in the air. The products should not be deposited more than 3 years in the above mentioned conditions since the producing date.

10 Accessory

NM3 Panel for installation. Outline dimensions are illustrated below:

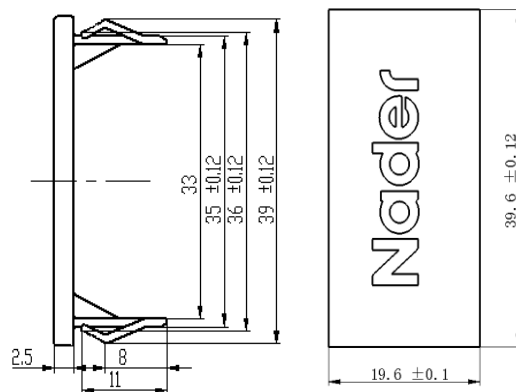

File number	NDT500478	Version	5 version	Date	20181030
-------------	-----------	---------	-----------	------	----------

11 Notices

- 11.1 Please maintain the distance of 30mm min. from the arc jet slot of the product (LINE side) during installation in case there is short circuit breaker due to arc jet.
- 11.2 Manufacturer will take no responsibility for problems caused by disassembly privately.
- 11.3 Attention to live part when the breaker is energized and avoid touching them.
- 11.4 Please make sure reliable connection to avoid fault tripping or damage of terminal caused by exceptional heat resulting from unsuitable connection.
- 11.5 When installing the circuit breaker with rocker guard, please embed the circuit breaker in the installation panel first, then place the rocker guard well and fix it with screws.