



***EZ-7750 72 x 72 DIN Size  
Time Relay with Analogue Set***

- *Selectable Analogue Scale ((0...60) or (0...600)) with DIP Switch*
- *Selectable Time Base (Second or Minute) with DIP Switch*
- *Selectable Operation Form with DIP Switch (On Delay or Off Delay)*
- *Selectable Automatic or Manual Reset Function with DIP Switch*

## ABOUT INSTRUCTION MANUAL

Instruction manual of EZ-7750 Analogue Time Relay consists of two main sections. Explanation of these sections are below. Also, there are other sections which include order information and technical specifications of the device. All titles and page numbers in instruction manual are in “**CONTENTS**” section. User can reach to any title with section number.

### **Installation:**

In this section, physical dimensions of the device, panel mounting, electrical wiring, physical and electrical installation of the device to the system are explained.

### **Operation :**

In this section, user interface of the device, definitions of operation form are explained.

Also in these sections, there are warnings to prevent serious injury while doing the physical and electrical mounting or using the device.

Explanation of the symbols which are used in these sections are given below.



This symbol is used for safety warnings. User must pay attention to these warnings.



This symbol is used to determine the dangerous situations as a result of an electric shock. User must pay attention to these warnings definitely.



This symbol is used to determine the important notes about functions and usage of the device.

# CONTENTS

|   |      |    |
|---|------|----|
| <b>1.PREFACE</b> .....  | Page | 5  |
| 1.1 GENERAL SPECIFICATIONS  |      |    |
| 1.2 ORDERING INFORMATION  |      |    |
| 1.3 WARRANTY  |      |    |
| 1.4 MAINTENANCE   |      |    |
| <b>2.INSTALLATION</b> .....                                       | Page | 7  |
| 2.1 GENERAL DESCRIPTION   |      |    |
| 2.2 DIMENSIONS  |      |    |
| 2.3 PANEL CUT-OUT   |      |    |
| 2.4 ENVIRONMENTAL RATINGS   |      |    |
| 2.5 PANEL MOUNTING  |      |    |
| 2.6 INSTALLATION FIXING CLAMP                                     |      |    |
| 2.7 REMOVING FROM THE PANEL                                       |      |    |
| <b>3.ELECTRICAL WIRINGS</b> .....                                 | Page | 12 |
| 3.1 TERMINAL LAYOUT AND CONNECTION INSTRUCTIONS                   |      |    |
| 3.2 ELECTRICAL WIRING DIAGRAM                                     |      |    |
| 3.3 VIEW OF THE DEVICE LABEL                                      |      |    |
| 3.4 SUPPLY VOLTAGE INPUT CONNECTION OF THE DEVICE                 |      |    |
| 3.5 GALVANIC ISOLATION TEST VALUES OF EZ-7750 ANALOGUE TIME RELAY |      |    |
| 3.6 RELAY OUTPUT CONNECTION                                       |      |    |
| 3.7 TRANSISTOR OUTPUT CONNECTION                                  |      |    |
| <b>4.FRONT PANEL DEFINITION AND OPERATION SETTINGS</b> .....      | Page | 18 |
| 4.1 FRONT PANEL DEFINITION  |      |    |
| 4.2 OPERATION SETTINGS  |      |    |
| 4.2.1 SELECTION OF SET VALUES AND SCALE                           |      |    |
| 4.2.2.TIME UNIT SELECTION   |      |    |
| 4.2.3 OUTPUT FORM SELECTION                                       |      |    |
| 4.2.4 RESET TYPE SELECTION  |      |    |
| 4.3 OUTPUT FORMS  |      |    |
| <b>5.SPECIFICATIONS</b> .....                                     | Page | 22 |

## EU DECLARATION OF CONFORMITY

**Manufacturer Company Name** : Emko Elektronik A.S.

**Manufacturer Company Address:** DOSAB, Karanfil Sokak, No:6, 16369 Bursa, Turkiye

**The manufacturer hereby declares that the product conforms to the following standards and conditions.**

**Product Name** : Analogue Time Relay

**Model Number** : EZ-7750

**Type Number** : EZ-7750

**Product Category** : Electrical equipment for measurement, control and laboratory use

**Has been designed and manufactured to the following specifications :**

EN 61000-6-4:2007 EMC Generic Emission Standard for the Industrial Environments

EN 61000-6-2:2005 EMC Generic Immunity Standard for the Industrial Environments

EN 61010-1:2001 Safety Requirements for electrical equipment for measurement, control And laboratory use

---

### **When and Where Issued**

16<sup>th</sup> October 2009

Bursa-TURKEY

### **Authorized Signature**

Name : Serpil YAKIN

Position : Quality Manager

## 1.Preface

EZ Series Analogue Time Relays are designed for measuring and controlling the time. They can be used in many applications with their simple and easy-use and selectable time base properties.

Some application fields which they are used are below:

### Application Fields

Glass  
Plastic  
Petro-Chemistry  
Textile  
Automotive  
Machine production industries

## 1.1 General Specifications

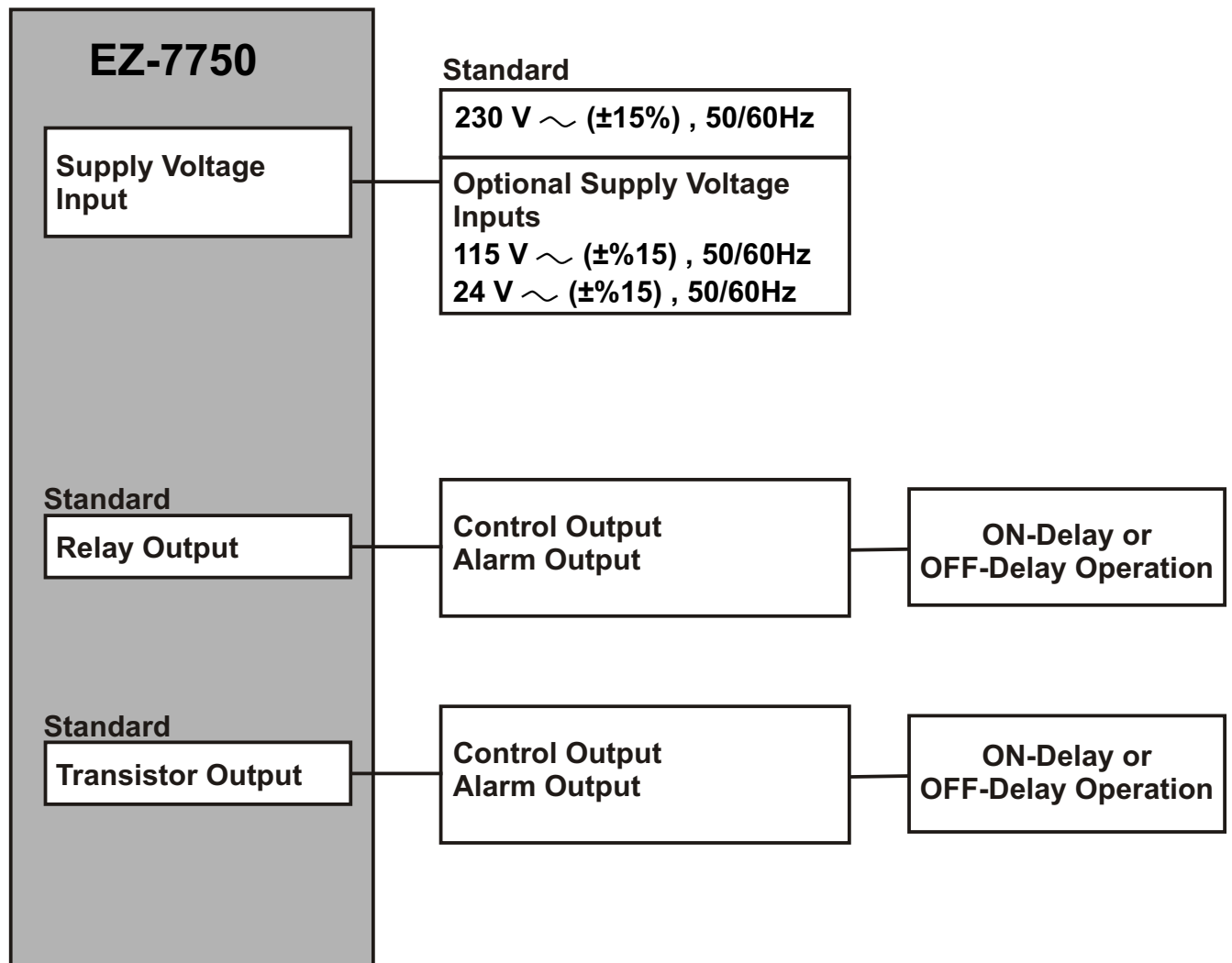

## 1.2 Ordering Information

|                                 |   |   |    |   |   |   |    |    |   |   |   |   |   |
|---------------------------------|---|---|----|---|---|---|----|----|---|---|---|---|---|
| <b>EZ-7750</b> (72x72 DIN Size) |   | A | BC | D | E | / | FG | HI | / | U | V | W | Z |
|                                 |   |   | 00 | 0 | 5 | / | 00 | 00 | / |   |   |   |   |
| <b>A</b>                        | <b>Supply Voltage</b>                               |   |    |   |   |   |    |    |   |   |   |   |   |
| 3                               | 24V $\sim$ ( $\pm 15\%$ ) 50/60Hz                   |   |    |   |   |   |    |    |   |   |   |   |   |
| 4                               | 115V $\sim$ ( $\pm 15\%$ ) 50/60Hz                  |   |    |   |   |   |    |    |   |   |   |   |   |
| 5                               | 230V $\sim$ ( $\pm 15\%$ ) 50/60Hz                  |   |    |   |   |   |    |    |   |   |   |   |   |
| 9                               | Customer  |   |    |   |   |   |    |    |   |   |   |   |   |
| <b>E</b>                        | <b>Output-1</b>                                     |   |    |   |   |   |    |    |   |   |   |   |   |
| 5                               | Relay & Transistor output(They operate synchronous) |   |    |   |   |   |    |    |   |   |   |   |   |
| <b>U</b>                        | <b>Time Unit</b>                                    |   |    |   |   |   |    |    |   |   |   |   |   |
| 0                               | Second  |   |    |   |   |   |    |    |   |   |   |   |   |
| 1                               | Minute  |   |    |   |   |   |    |    |   |   |   |   |   |
| <b>V</b>                        | <b>Scale Selection</b>                              |   |    |   |   |   |    |    |   |   |   |   |   |
| 0                               | X1 ( 0...60 )                                       |   |    |   |   |   |    |    |   |   |   |   |   |
| 1                               | X10 ( 0...600 )                                     |   |    |   |   |   |    |    |   |   |   |   |   |
| <b>W</b>                        | <b>Operation Type</b>                               |   |    |   |   |   |    |    |   |   |   |   |   |
| 0                               | On Delay  |   |    |   |   |   |    |    |   |   |   |   |   |
| 1                               | Off Delay   |   |    |   |   |   |    |    |   |   |   |   |   |
| <b>Z</b>                        | <b>Reset Type Selection</b>                         |   |    |   |   |   |    |    |   |   |   |   |   |
| 0                               | Automatic Reset (Reset Time = 4 Seconds)            |   |    |   |   |   |    |    |   |   |   |   |   |
| 1                               | Manual Reset  |   |    |   |   |   |    |    |   |   |   |   |   |

All order information of EZ-7750 Analogue Time Relay are given on the table at left. User may form appropriate device configuration from information and codes that at the table and convert it to the ordering codes.

Firstly, supply voltage then other specifications must be determined. Please fill the order code blanks according to your needs.

Please contact us, if your needs are out of the standards.



$\sim$  Symbol means Vac,  
 $\equiv$  Symbol means Vdc

## 1.3 Warranty

EMKO Elektronik warrants that the equipment delivered is free from defects in material and workmanship. This warranty is provided for a period of two years. The warranty period starts from the delivery date. This warranty is in force if duty and responsibilities which are determined in warranty document and instruction manual performs by the customer completely.

## 1.4 Maintenance

Repairs should only be performed by trained and specialized personnel. Cut power to the device before accessing internal parts.

Do not clean the case with hydrocarbon-based solvents (Petrol, Trichlorethylene etc.). Use of these solvents can reduce the mechanical reliability of the device. Use a cloth dampened in ethyl alcohol or water to clean the external plastic case.

## 2. Installation



Before beginning installation of this product, please read the instruction manual and warnings below carefully.

In package ,

- One piece unit
- Two pieces mounting clamps
- One piece instruction manual

A visual inspection of this product for possible damage occurred during shipment is recommended before installation. It is your responsibility to ensure that qualified mechanical and electrical technicians install this product.

If there is danger of serious accident resulting from a failure or defect in this unit, power off the system and separate the electrical connection of the device from the system.

The unit is normally supplied without a power switch or a fuse. Use power switch and fuse as required.

Be sure to use the rated power supply voltage to protect the unit against damage and to prevent failure.

Keep the power off until all of the wiring is completed so that electric shock and trouble with the unit can be prevented.

Never attempt to disassemble, modify or repair this unit. Tampering with the unit may results in malfunction, electric shock or fire.

Do not use the unit in combustible or explosive gaseous atmospheres.

During the equipment is putted in hole on the metal panel while mechanical installation some metal burrs can cause injury on hands, you must be careful.

Montage of the product on a system must be done with it's own fixing clamps. Do not do the montage of the device with inappropriate fixing clamps. Be sure that device will not fall while doing the montage.

It is your responsibility if this equipment is used in a manner not specified in this instruction manual.

## 2.1 General Description

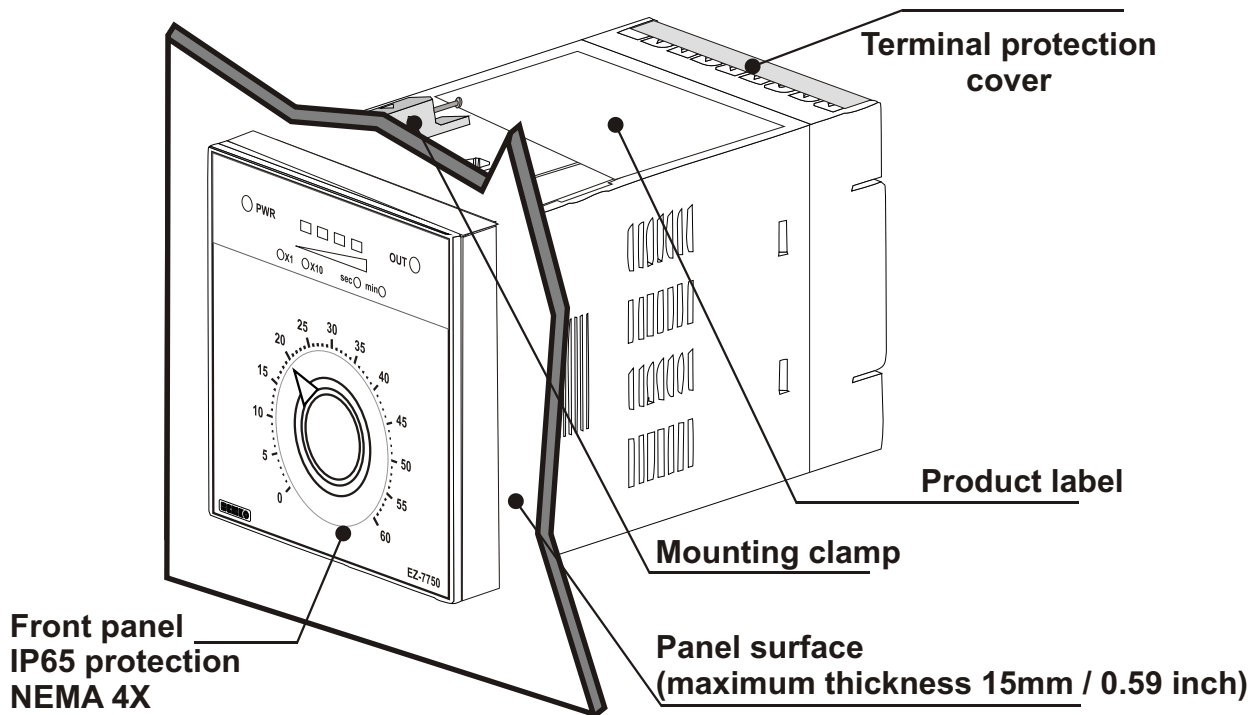

## 2.2 Dimensions

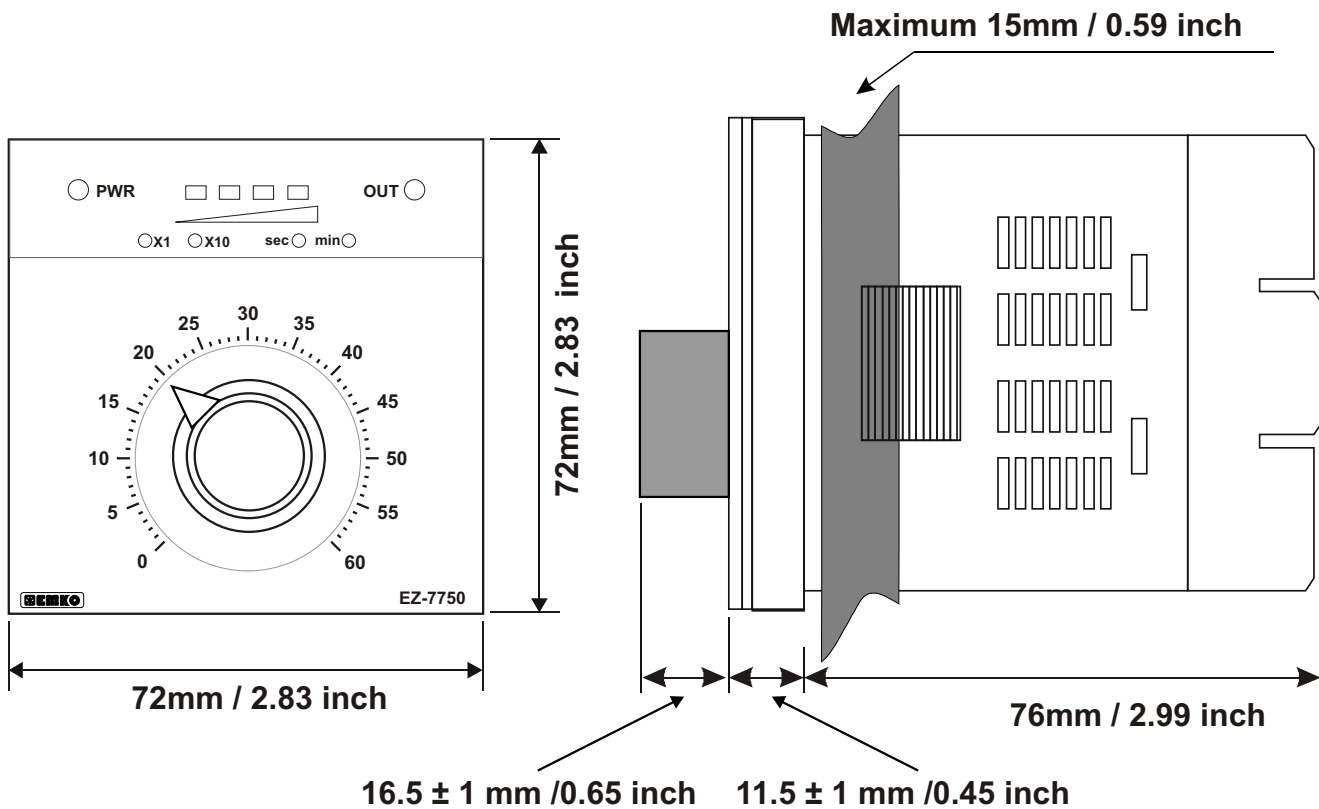



**2.3 Panel Cut-Out**

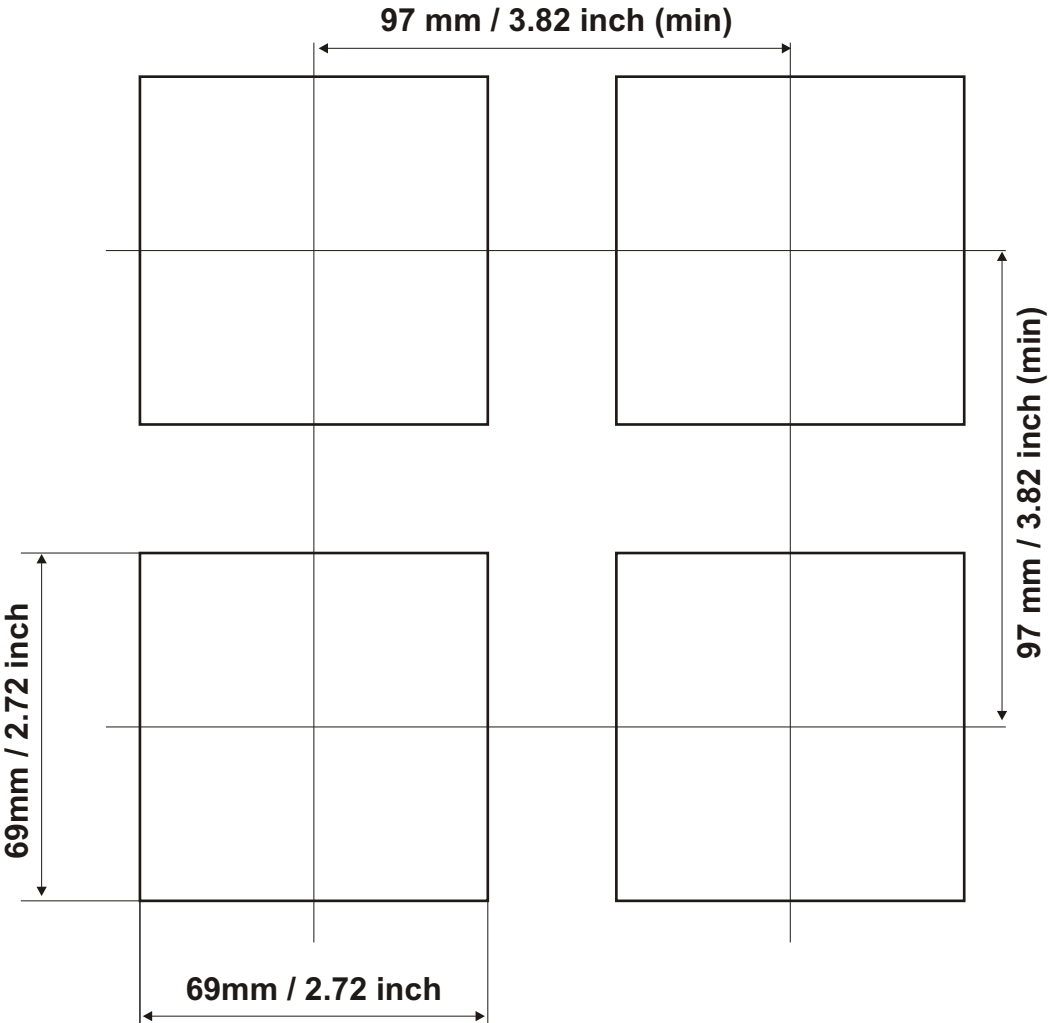

## 2.4 Environmental Ratings

### Operating Conditions



**Operating Temperature** : 0 to 50 °C



**Max. Operating Humidity** : 90% Rh (non-condensing)



**Altitude** : Up to 2000m.



**Forbidden Conditions:**

Corrosive atmosphere

Explosive atmosphere

Home applications (The unit is only for industrial applications)

## 2.5 Panel Mounting

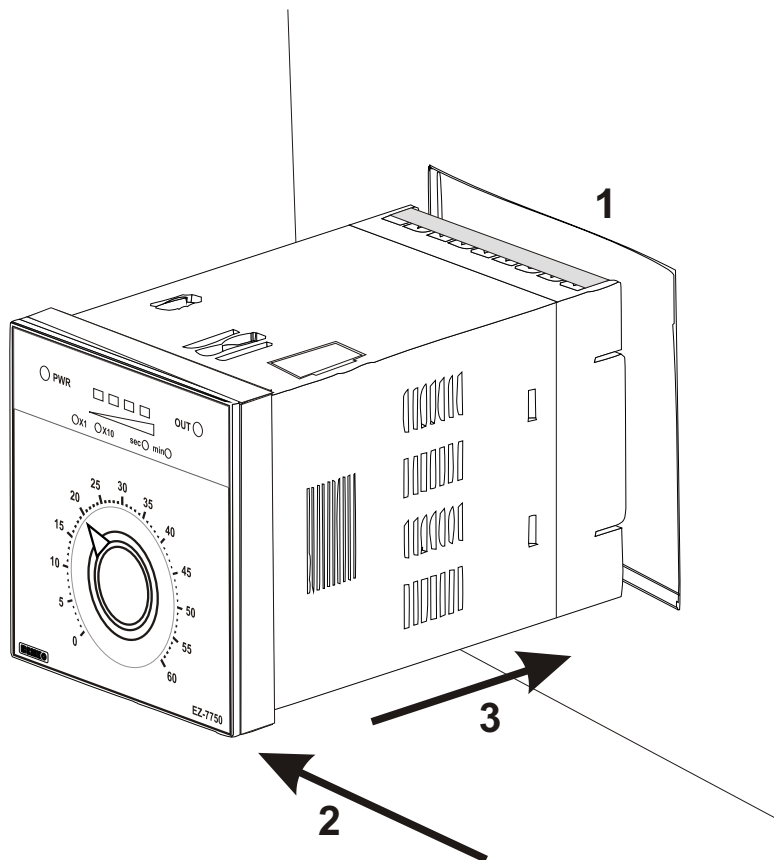

1-Before mounting the device in your panel, make sure that the cut-out is of the right size.

2-Check front panel gasket position

3-Insert the device through the cut-out. If the mounting clamps are on the unit, put out them before inserting the unit to the panel.



During installation into a metal panel, care should be taken to avoid injury from metal burrs which might be present. The equipment can loosen from vibration and become dislodged if installation parts are not properly tightened. These precautions for the safety of the person who does the panel mounting.

## 2.6 Installation Fixing Clamp

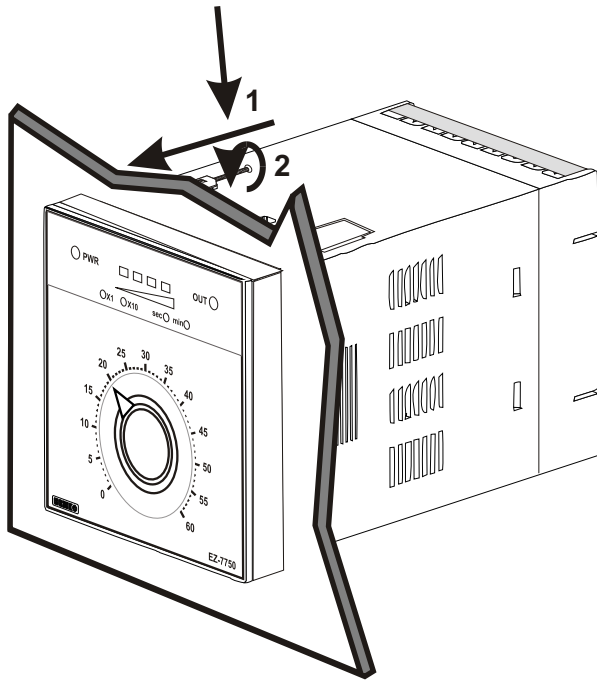

The unit is designed for panel mounting.

1-Insert the unit in the panel cut-out from the front side.

2- Insert the mounting clamps to the holes that located top and bottom sides of device and screw up the fixing screws until the unit completely immobile within the panel



**Montage of the unit to a system must be done with it's own fixing clamps. Do not do the montage of the device with inappropriate fixing clamps. Be sure that device will not fall while doing the montage.**

## 2.7 Removing from the Panel



**Before starting to remove the unit from panel, power off the unit and the related system.**

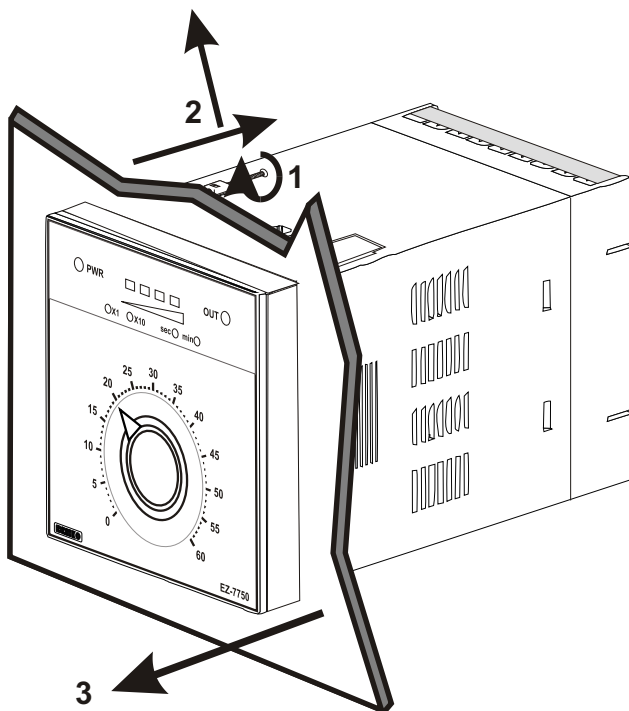

1-Loosen the screws.

2-Pull mounting clamps from top and bottom fixing sockets.

3-Pull the unit through the front side of the panel

### 3. Electrical Wirings



You must ensure that the device is correctly configured for your application. Incorrect configuration could result in damage to the process being controlled, and/or personal injury. It is your responsibility, as the installer, to ensure that the configuration is correct.

Device parameters has factory default values. These parameters must be set according to the system's needs.



Only qualified personnel and technicians should work on this equipment. This equipment contains internal circuits with voltage dangerous to human life. There is severe danger for human life in the case of unauthorized intervention.



Be sure to use the rated power supply voltage to protect the unit against damage and to prevent failure.



Keep the power off until all of the wiring is completed so that electric shock and trouble with the unit can be prevented.

#### 3.1 Terminal Layout and Connection Instructions

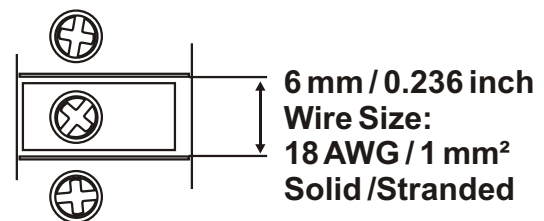
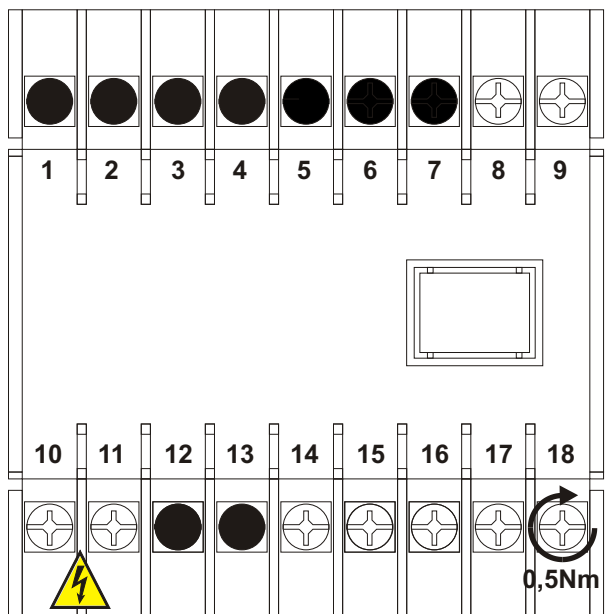

### 3.2 Electrical Wiring Diagram



Electrical wiring of the device must be the same as 'Electrical Wiring Diagram' below to prevent damage to the process being controlled and personnel injury.

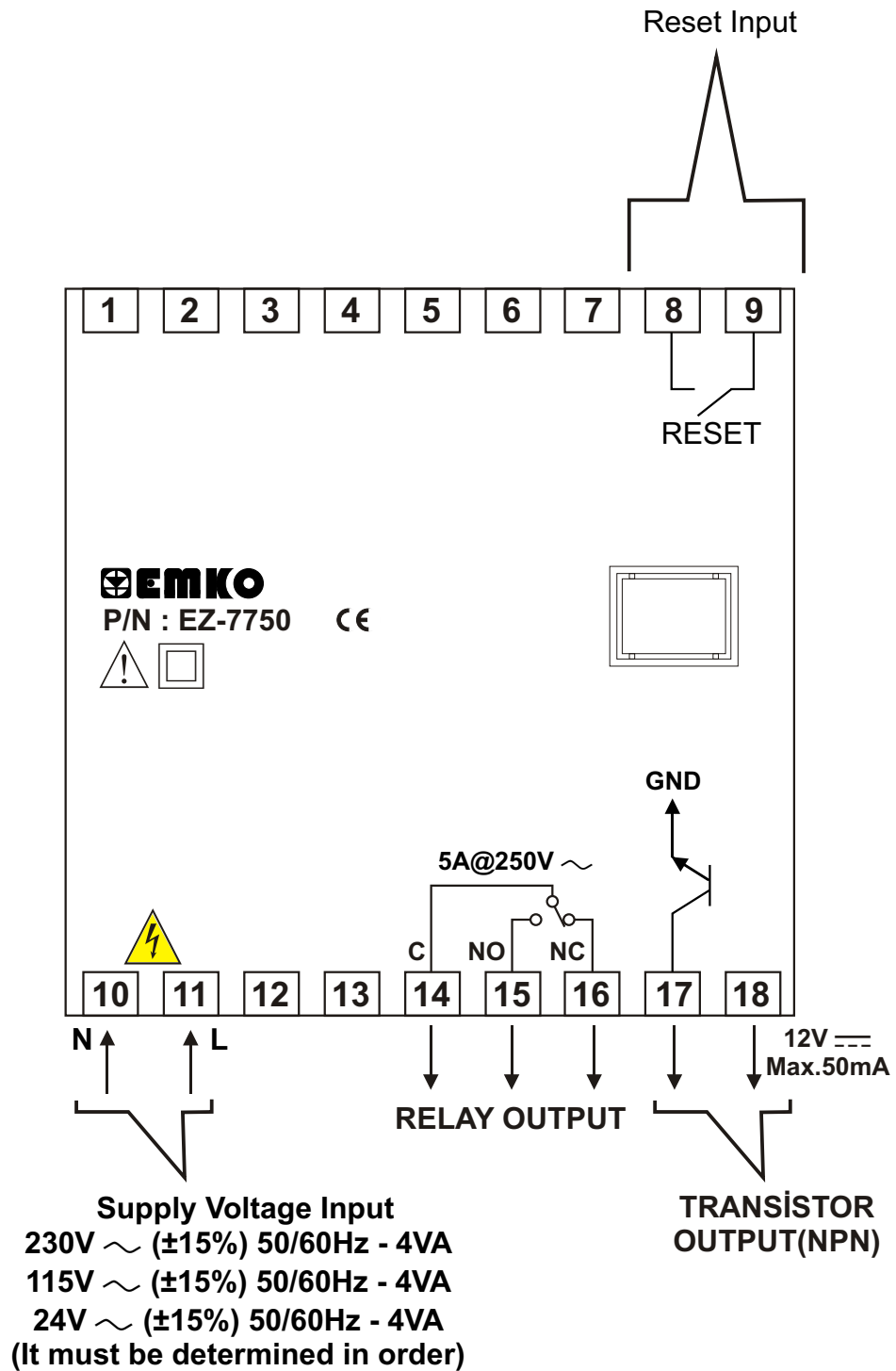

### 3.3 View of the Device Label

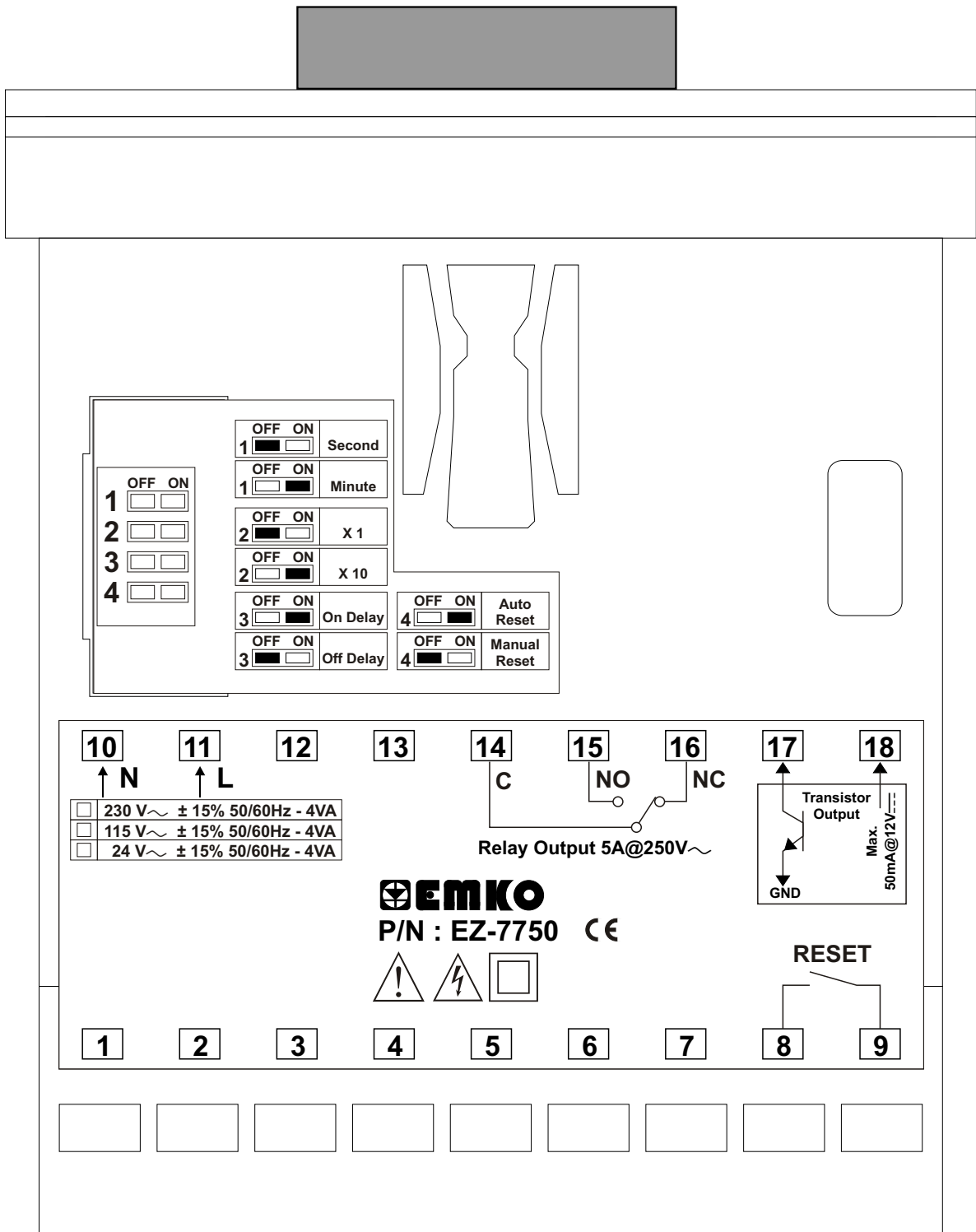

### 3.4 Supply Voltage Input Connection of the Device

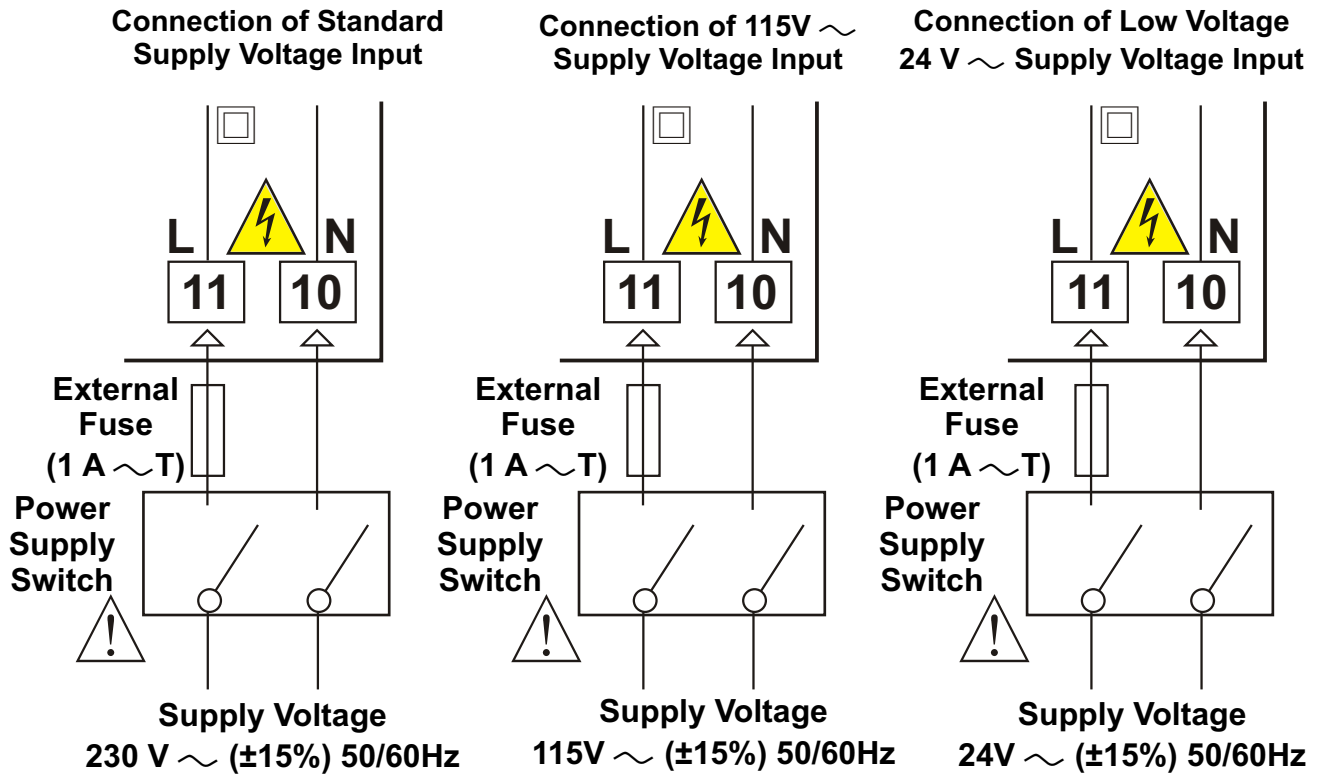

Supply voltage range must be determined in order. While installing the unit, supply voltage range must be controlled and appropriate supply voltage must be applied to the unit. Controlling prevents damages in unit and system and possible accidents as a result of incorrect supply voltage.



There is no power switch or fuse on the device. So a power switch and a fuse must be added to the supply voltage input. Power switch and fuse must be put to a place where user can reach easily.



Power switch must be two poled for seperating phase and neutral. On/Off condition of power switch is very important in electrical connection. On/Off condition of power switch must be signed for preventing the wrong connection.



External fuse must be on phase connection in ~ supply input.

### 3.5 Galvanic Isolation Test Values of EZ-7750 Analogue Time Relay

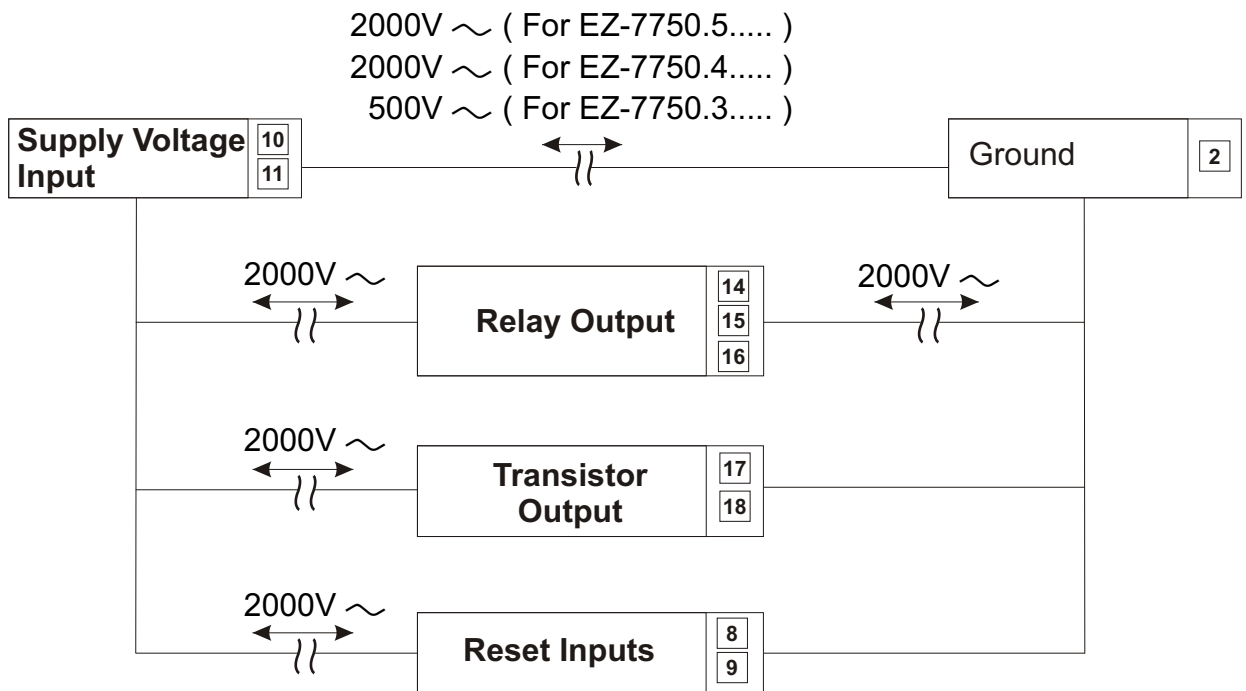

### 3.6 Relay Output Connection

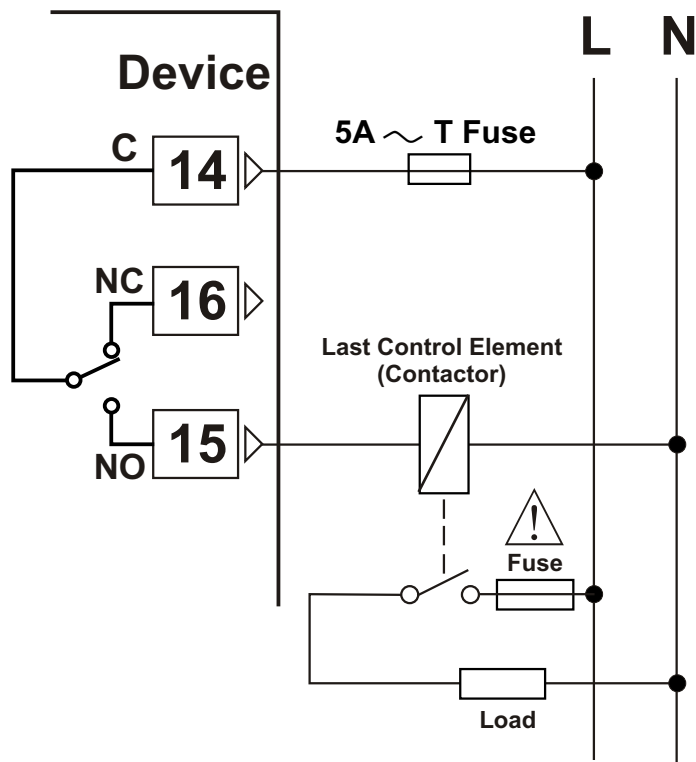

Fuses must be selected according to the applications



### 3.7 Transistor Output Connection

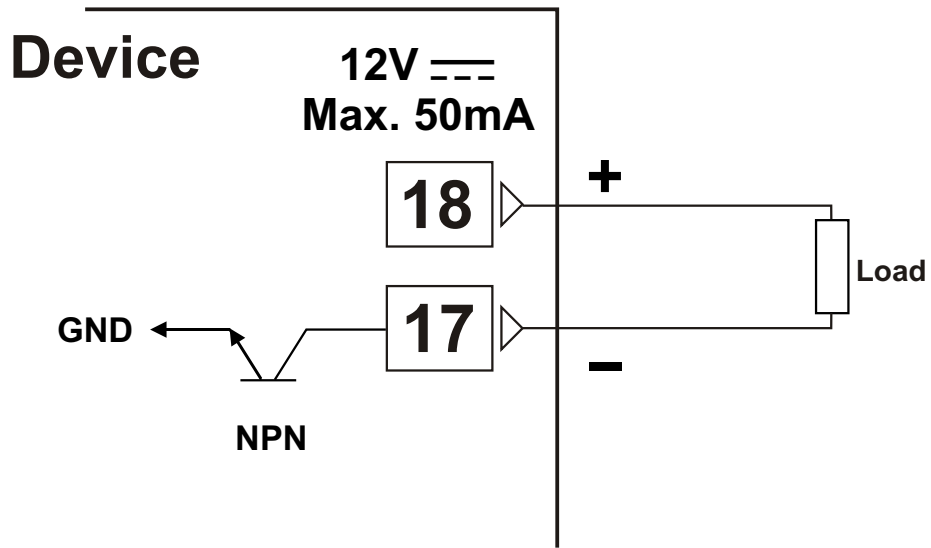

## 4. Front Panel Definition and Operation Settings

### 4.1 Front Panel Definition

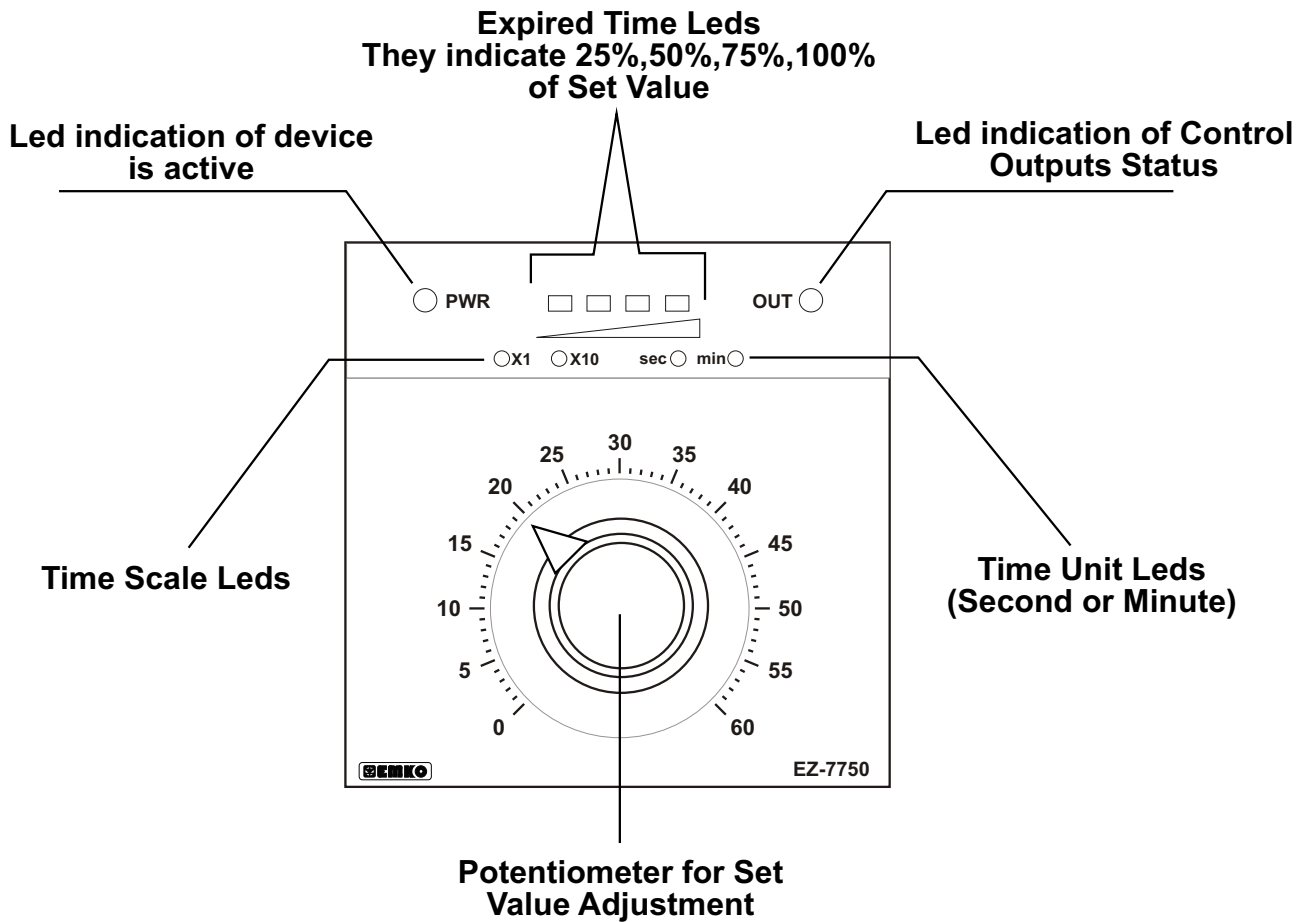

Operation settings of the device is adjusted by changing the position of the DIP Switch that is on the device.

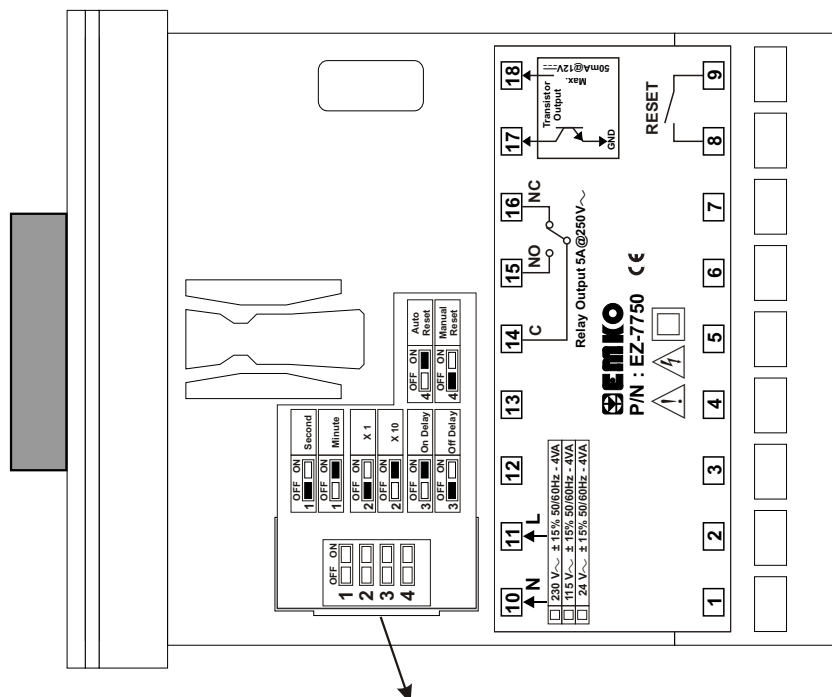

DIP Switch is under cover and cover is on top side of the device

## 4.2 Operation Settings

### 4.2.1 Set Values

SET value can be adjusted with SET Value Adjustment Potentiometer that is on the front panel. Also, by changing the position of DIP Switch which is used for scale selection, 0...60 (x1) or 0...600 (x10) scale can be selected.

#### Scale Selection

|  |                           |
|--|---------------------------|
| OFF ON<br>2 <input checked="" type="checkbox"/> <input type="checkbox"/> | x1 (0...60) is selected   |
| OFF ON<br>2 <input type="checkbox"/> <input checked="" type="checkbox"/> | x10 (0...600) is selected |

### 4.2.2 Time Unit Selection

By changing the position of the DIP Switch which is used for time unit selection, second or minute can be selected.

#### Time Unit Selection

|  |                    |
|--|--------------------|
| OFF ON<br>1 <input checked="" type="checkbox"/> <input type="checkbox"/> | Second is selected |
| OFF ON<br>1 <input type="checkbox"/> <input checked="" type="checkbox"/> | Minute is selected |

### 4.2.3 Operation Form Selection

By changing the position of the DIP Switch which is used for output form selection, on delay or off delay can be selected.

#### Operation Form Selection

|  |           |
|--|-----------|
| OFF ON<br>3 <input checked="" type="checkbox"/> <input type="checkbox"/> | On Delay  |
| OFF ON<br>3 <input type="checkbox"/> <input checked="" type="checkbox"/> | Off Delay |

### 4.2.4 Reset Type Selection

By changing the position of the DIP Switch which is used for Reset Type selection, manual reset or automatic reset can be selected.

#### Reset Type Selection

|  |                             |
|--|-----------------------------|
| OFF ON<br>4 <input checked="" type="checkbox"/> <input type="checkbox"/> | Manual Reset is selected    |
| OFF ON<br>4 <input type="checkbox"/> <input checked="" type="checkbox"/> | Automatic Reset is selected |

## 4.3 Output Forms

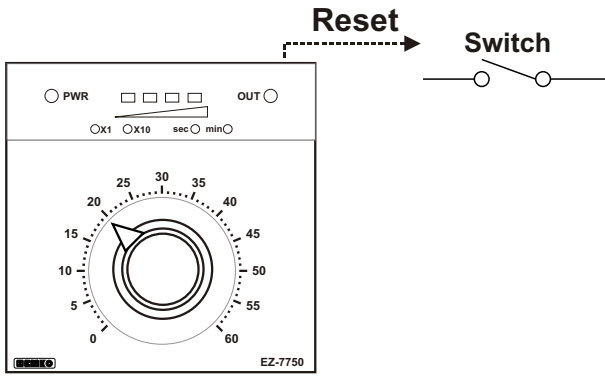

### EXAMPLE-1 : (Manual Reset)

DIP Switch position(4) is adjusted as Manual Reset. There is a switch in reset input for start/stop signal.

When switch is "On/Off", counting is started (It can be minute or second, it is selected by changing the position of Dip Switch(1)). When count value is equal to 1/4 of set value first led, when count value is equal to 1/2 of set value second led, when count value is equal to 3/4 of set value third led, when count value is equal to set value fourth led becomes active and outputs are energised. When switch is "On", outputs become inactive, counting does not start. For starting the counting switch must be "Off".

**ON DELAY and  
MANUAL RESET**

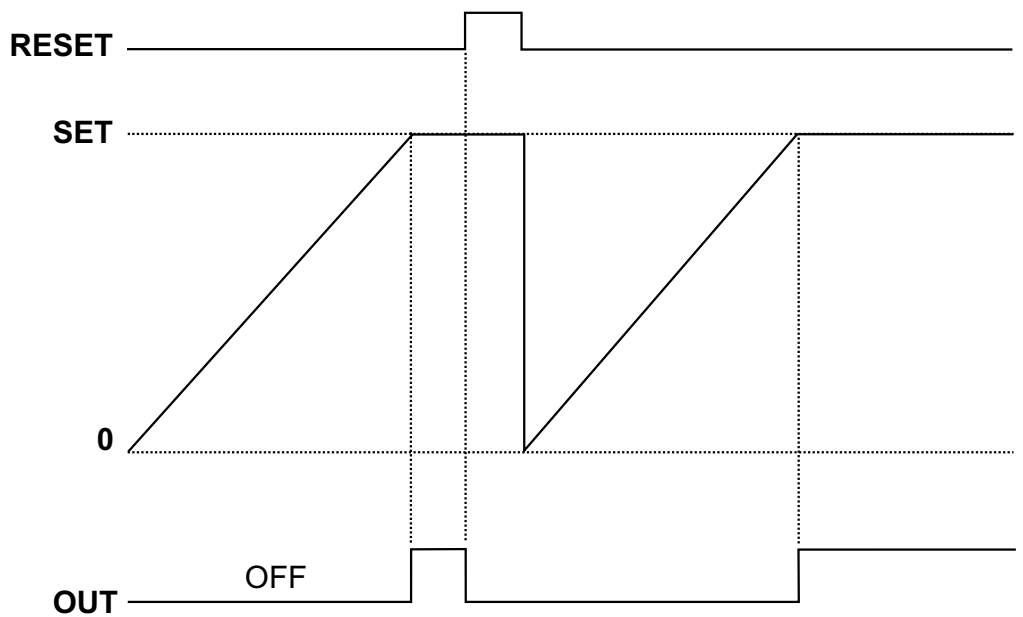

**OFF DELAY  
and MANUAL RESET**

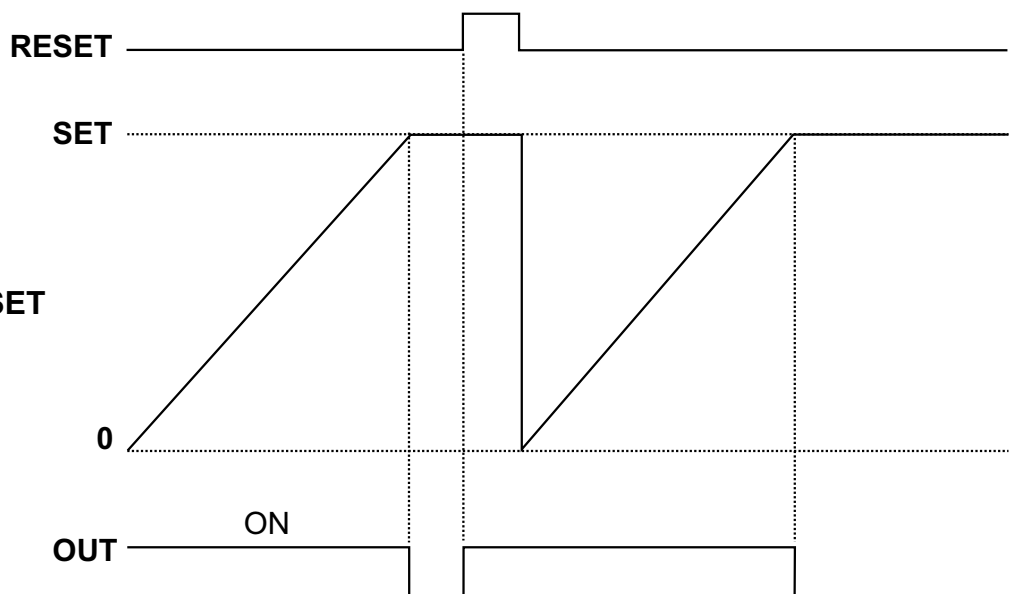

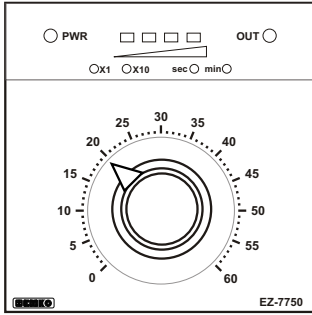

### EXAMPLE-2 : (Automatic Reset)

DIP Switch position(4) is adjusted as Automatic Reset. Counting is started when device is energised. When count value is equal to Set value outputs becomes active and being active lasts for 4 seconds. After 4 seconds, outputs become inactive and counting is started from 0.

#### ON DELAY and AUTOMATIC RESET

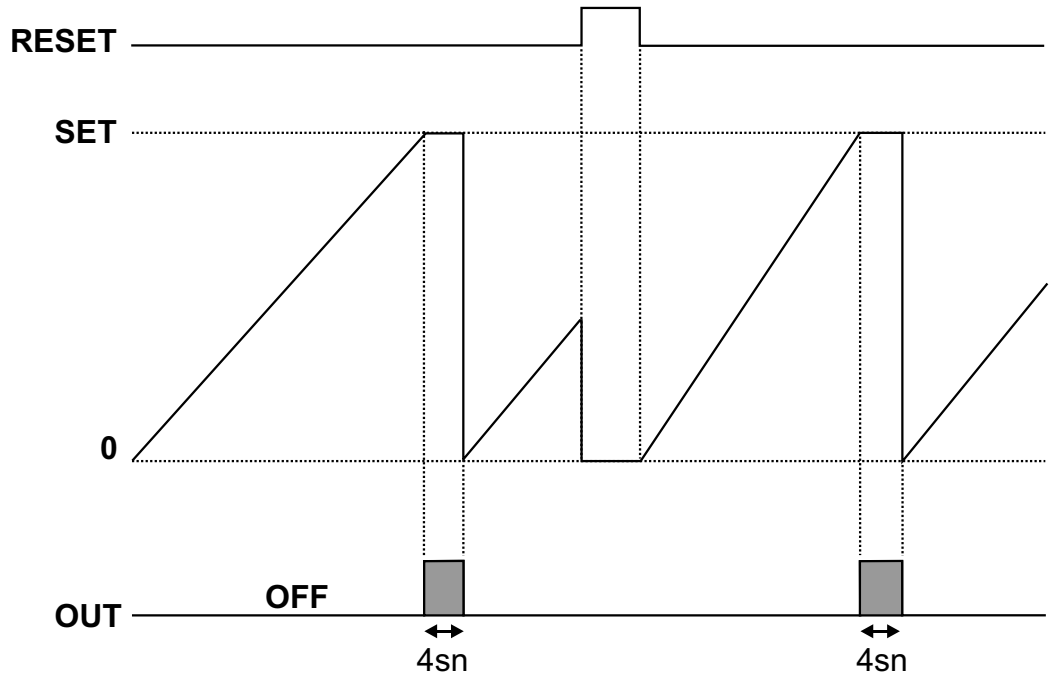

#### OFF DELAY and AUTOMATIC RESET

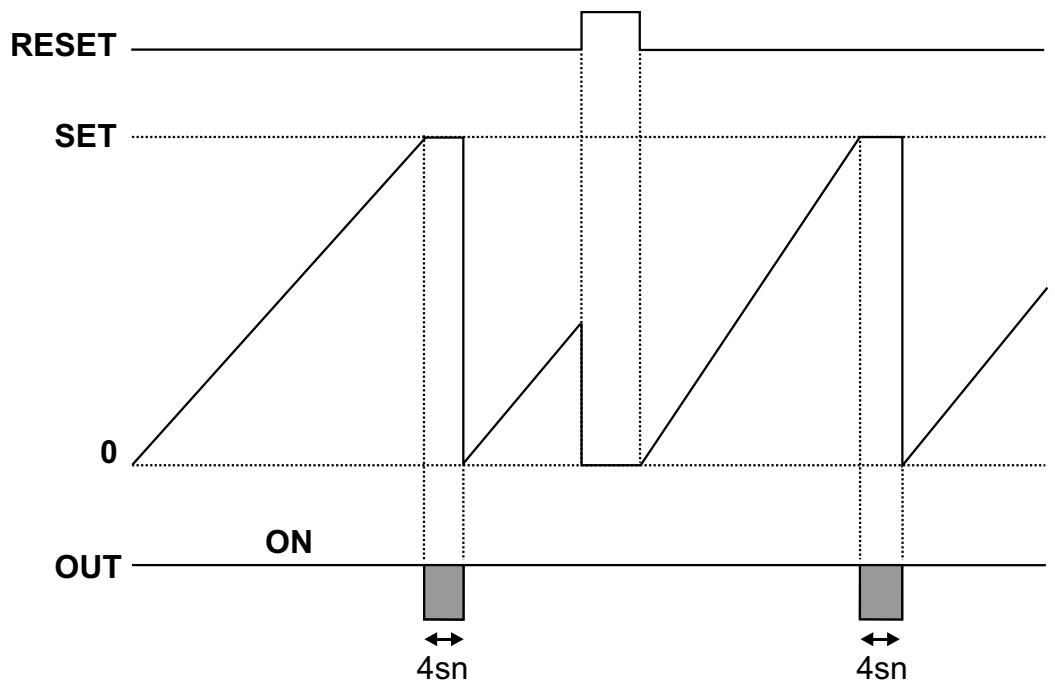

Automatic Reset is realised after 4 seconds of being equal to Set value

## 5. Specifications

|                                      |  |
|--------------------------------------|--|
| <b>Device Type</b>                   | : Analogue Time Relay  |
| <b>Housing&amp;Mounting</b>          | : 72mm x 72mm x 104mm DIN Size 43700 plastic housing for panel mounting. Panel cut-out is 69x69mm.                                     |
| <b>Protection Class</b>              | : NEMA 4X (IP65 at front, IP20 at rear).   |
| <b>Weight</b>                        | : Approximately 0.30 Kg.   |
| <b>Environmental Ratings</b>         | : Standard, indoor at an altitude of less than 2000 meters with none condensing humidity.  |
| <b>Storage/Operating Temperature</b> | : -40 °C to +85 °C / 0 °C to +50 °C  |
| <b>Storage/Operating Humidity</b>    | : 90 % max. (None condensing)  |
| <b>Installation</b>                  | : Fixed installation   |
| <b>Overvoltage Category</b>          | : II   |
| <b>Pollution Degree</b>              | : II, office or workplace, none conductive pollution   |
| <b>Operating Conditions</b>          | : Continuous   |
| <b>Supply Voltage and Power</b>      | : 230V ~ (±15%) 50/60 Hz. 4VA<br>115V ~ (±15%) 50/60 Hz. 4VA<br>24V ~ (±15%) 50/60 Hz. 4VA   |
| <b>Resolution of Set Point</b>       | : ± 0.2% of full scale   |
| <b>Accuracy of Set Point</b>         | : ±1%  |
| <b>Relay Output</b>                  | : 5A@250V ~ (Electrical Life : 100.000 Operation (Full Load))  |
| <b>Transistor Output</b>             | : Maximum 50mA@12V === NPN   |
| <b>LED Indicators</b>                | : PWR (Green) , OUT (Red) , Sec (Second)(Red) , Min(Minute) (Red) , X1 (Red) , X10 (Red) , Expired Time Leds : 4 pieces of led (Green) |

## 6. Other Informations

### Manufacturer Information:

Emko Elektronik Sanayi ve Ticaret A.Ş.  
Demirtaş Organize Sanayi Bölgesi Karanfil Sk. No:6 16369  
BURSA/TURKEY

Phone : +90 224 261 1900

Fax : +90 224 261 1912

### Repair and Maintenance Service Information:

Emko Elektronik Sanayi ve Ticaret A.Ş.  
Demirtaş Organize Sanayi Bölgesi Karanfil Sk. No:6 16369  
BURSA/TURKEY

Phone : +90 224 261 1900

Fax : +90 224 261 1912



Thank you very much for your preference to use Emko Elektronik Products.

[www.emkoelektronik.com.tr](http://www.emkoelektronik.com.tr)