

## Railway applications

- Relays
- Time relays
- Monitoring relays
- Sockets



### Reliable and Safe Solutions for Railway and Transportation Applications

Solutions for the transport market need to guarantee safety, security and comfort. The applications are expected to last a long time under challenging conditions. Be it for high-speed trains, metros, subways or other rail vehicles – in tunnels, on bridges, in train stations, airports, on the open track, or in harbor facilities, the Comat Releco Group has the right solution for different kind of applications. We offer a wide range of relays, control and monitoring devices that are developed in compliance with the European Railway Standard EN 50155 (including also EN 61373, EN 45545 and NF F 16-101/102).

The EN 50155 standard applies for all electronic devices such as command, control, protection units, as well as power supplies, which are used in the transportation market. It applies either to the accumulator battery side or also the low-voltage power supply part of the vehicle.

Regarding fire protection, the products offered in this brochure are manufactured in accordance with standard NF F 16-101/102.

A table at the last page of this brochure shows the overview of the products and the standards they comply with. Individual declarations of conformity are available on demand. Please do not hesitate to contact us for any further questions or comments.

The Comat Releco Group

[info@comat.ch](mailto:info@comat.ch)

Comat AG  
Bernstrasse 4  
3076 Worb  
Switzerland

Releco S.A.  
La Laguna 30  
28923 Alcorcón, Madrid  
Spain

[www.comat.ch](http://www.comat.ch)

[www.releco.com](http://www.releco.com)

# Index

Relays

1

<b>1. Relays</b>		Page 3
Long life series with single contacts	<b>C31D/R</b>	4
Long life series with twin contacts	<b>C32D/R</b>	5
Standard relay	<b>R3-N3x</b>	6
Standard relay	<b>R4-A4x</b>	7
Miniature relay	<b>R7-A2x</b>	8
Miniature relay	<b>R7-T2x</b>	9
Interface relay	<b>CINT-21</b>	10
Interface relay	<b>CINT-22</b>	11
Interface relay	<b>CINT-25</b>	12
Interface relay	<b>CINT-61</b>	13
Interface relay	<b>CINT-62</b>	14
Interface relay	<b>CINT-63</b>	15
Signal relay	<b>C203.06R</b>	16
Power relay	<b>RIC20-x</b>	17
Power relay	<b>RIC25-x</b>	18

Time Relays

2

<b>2. Time Relays</b>		Page 19
Time functions		20
Multifunction Timer, relay change-over	<b>CIM1R</b>	21
Multifunction Timer, solid-state AC	<b>CIM12R</b>	22
Multifunction Timer, solid-state DC	<b>CIM13R</b>	23
Multifunction Timer, relay change-over	<b>CIM2R</b>	24
Multifunction Timer, solid-state AC	<b>CIM22R</b>	25
Multifunction Timer, solid-state DC	<b>CIM23R</b>	26
Multifunction Timer, relay change-over	<b>CIM3R</b>	27
Multifunction Timer, semi-conductor AC	<b>CIM32R</b>	28
Multifunction Timer, semi-conductor DC	<b>CIM33R</b>	29
CT-System: Plug-in time modules	<b>CT32R, CT33R, CT36R</b>	30
Plug-in time relays	<b>CT32...R, CT33...R, CT36...R</b>	31

Monitoring Relays

3

<b>3. Monitoring Relays</b>		Page 33
1-phase monitoring	<b>MRU11R</b>	34
3-phase monitoring	<b>MRU32R</b>	35
1-phase monitoring	<b>MRI11R</b>	36
3-phase monitoring	<b>MRI32R</b>	37
1-phase monitoring	<b>MRM11R</b>	38
3-phase monitoring	<b>MRM32R</b>	39
CT-System: Plug-in current monitoring modules	<b>CT512R, CT515R, CT516R</b>	40
Plug-in current monitoring set	<b>CT512...R, CT515...R, CT516...R</b>	42
Plug-in DC voltage monitoring module	<b>CT524R</b>	41
Plug-in DC voltage monitoring set	<b>CT524...R</b>	42
Insulation monitoring	<b>ESU-D2R</b>	43

Sockets

4

<b>4. Sockets</b>		Page 45
Socket for 11 pin relays and plug-in modules	<b>C11A</b> (for relays: C31D/R, C32D/R, R3-N3)	46
Socket for 11 pin relays and plug-in modules	<b>C12B0</b> (for relays: C31D/R, C32D/R, R3-N3)	47
Socket for 14 pin relays	<b>CS-144</b> (for relays: R4-A4x)	48
Socket for miniature relays	<b>CS-18</b> (for relays: R7-x)	49

## Notes



# 1. Relays

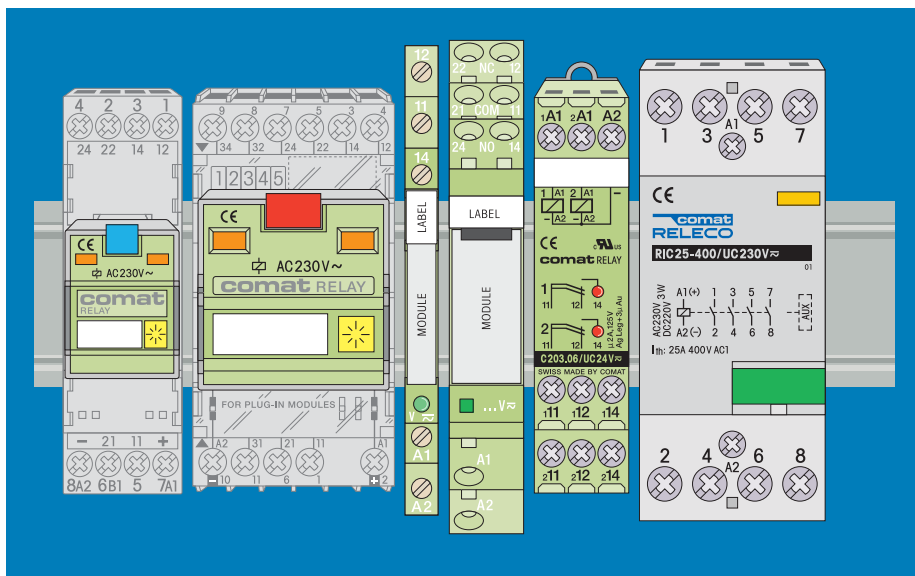

Application	Types	Output contacts	Design
11 pin plug-in, long life relay	<b>C31D/R</b>	10A, 250V AC-1	
11 pin plug-in, long life relay	<b>C32D/R</b>	6A, 250V AC-1	
11 pin plug-in, standard relay	<b>R3-N3...</b>	6A, 250V AC-1	
14 pin plug-in, standard relay	<b>R4-A4...</b>	10A, 250V AC-1	
8 pin plug-in, miniature standard relay	<b>R7-A2...</b>	10A, 250V AC-1	
8 pin plug-in, miniature standard relay	<b>R7-T2...</b>	6A, 250V AC-1	
Interface relay	<b>CINT-21</b>	6A, 250V AC-1	
Interface relay	<b>CINT-22</b>	6A, 250V AC-1	
Interface relay	<b>CINT-25</b>	2A, 250V AC-1	
Interface relay	<b>CINT-61</b>	10A, 250V AC-1	
Interface relay	<b>CINT-62</b>	8A, 250V AC-1	
Interface relay	<b>CINT-63</b>	8A, 250V AC-1	
Interface relay	<b>C203.06</b>	2x  2A, 125V AC-1	
Power relay	<b>RIC20-...</b>	20A, 230V AC-1	
Power relay	<b>RIC25-...</b>	25A, 230V AC-1	

Long life series with single contacts

## C31D/R

**11 pin plug-in relay, 3-pole, change-over contacts, according to IEC 60067**

### Type: C31D/R ...V

Long Life Relays for Railway application, 3 change-over contacts

Types with LED status indicator

Types with free wheeling diode

Manual actuator and mech. status indicator

**Maximum contact load** 10 A / 250 V AC-1

**Recommended minimum contact load** 10 A / 30 V DC-1

50 mA / 10 V

### Contacts

Type single contact micro disconnection

Material AgCuNi

Rated current 10 A

Inrush current max. (20 ms) 40 A

Switching voltage AC-1 max. 250 V

AC load max. 2500 VA AC-1

DC load max. see Fig. 2

### Coils (Values are valid at 20 °C)

Operating voltage range 0.7 ... 1.25 U<sub>N</sub>

Nominal power DC 1.2 W

### Coil Table

V <sub>N</sub> DC	Ω	mA
24	340	70
36	780	46
72	3200	23
110	9700	11

Types with LED indicator take additional 5 ... 10 mA @ < 80 V

### Insulation

Pulse (1.2 / 50 us / Dielectric strength (V rms, 1 minute)

Contact / coil - / 2.5 kV

Contact / contact - / 2.5 kV

Contact open - / 1.5 kV

### General Specifications

Ambient temperature operation / storage -40 ... +70 °C / -40 ... +85 °C

Pick-up time typ. 12 ms

Release time typ. 20 ms

Bounce time NO contact typ. 3.5 ms

Mechanical life ≥ 10<sup>8</sup> operations

Operating frequency at nominal load ≤ 360 operations / h

Ingress protection rating IP 40

Weight 80 g

### Standard types

**DC: 24, 36, 72, 110 V**

**C31D/R DC...V**

"..." Enter the voltage for full type designation

### Accessories

Socket: **C11A, C12B0**

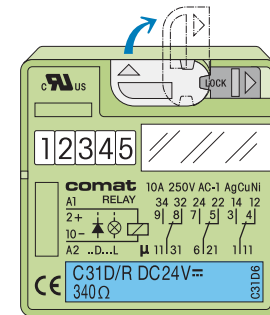

### Connection diagram

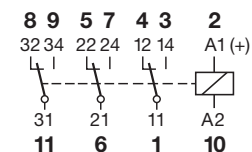

**Fig. 1 AC voltage endurance**

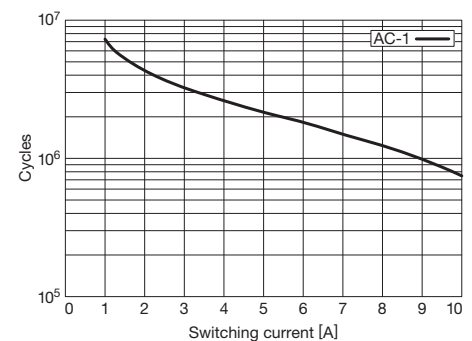

**Fig. 2 DC load limit curve**

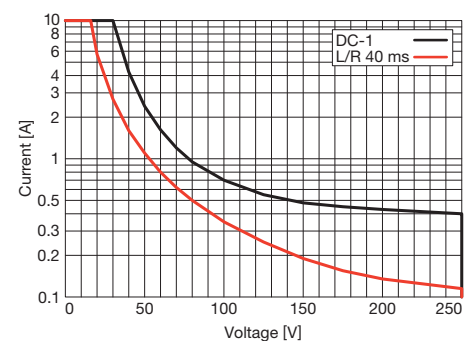

### Dimensions [mm]

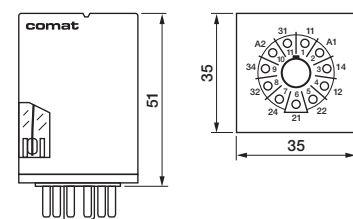

### Technical approvals, conformities

See table on page 53.

Long life series with twin contacts

## C32D/R

**11 pin plug-in relay, 3-pole, change-over twin contacts, according to IEC 60067**

### Type: C32D/R ...V

Long Life Relays for Railway application, 3 change-over twin contacts

Types with LED status indicator

Types with free wheeling diode

Manual actuator and mech. status indicator

<b>Maximum contact load</b>	<b>6 A / 250 V AC-1</b>
	<b>6 A / 30 V DC-1</b>
<b>Recommended minimum contact load</b>	<b>10 mA / 5 V</b>

### Contacts

Type	twin contact micro disconnection
Material	AgCuNi
Rated current	6 A
Inrush current max. (20 ms)	15 A
Switching voltage AC-1 max.	250 V
AC load max.	1500 VA AC-1
DC load max.	see Fig. 2

### Coils

(Values are valid at 20 °C)

Operating voltage range	0.7 ... 1.25 U <sub>N</sub>
Nominal power DC	1.2 W

### Coil Table

V <sub>N</sub> DC	Ω	mA
<b>24</b>	340	70
<b>36</b>	780	46
<b>110</b>	9700	11

Types with LED indicator take additional 5 ... 10 mA @ < 80 V

### Insulation

Pulse (1.2 / 50 us / Dielectric strength (V rms, 1 minute)

Contact / coil	- / 2.5 kV
Contact / contact	- / 2.5 kV
Contact open	- / 1.5 kV

### General Specifications

Ambient temperature operation / storage	-40 ... +70 °C / -40 ... +85 °C
Pick-up time typ.	12 ms
Release time typ.	20 ms
Bounce time NO contact typ.	3.5 ms
Mechanical life	≥ 10 <sup>8</sup> operations
Operating frequency at nominal load	≤ 360 operations / h
Ingress protection rating	IP 40
Weight	80 g

### Standard types

**DC: 24, 36, 110 V**

**C32D/R DC...V**

"..." Enter the voltage for full type designation

### Accessories

Socket: **C11A, C12B0**

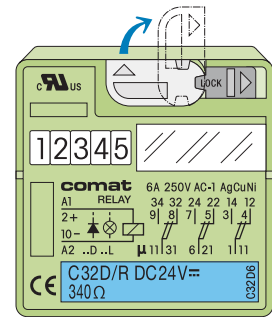

### Connection diagram

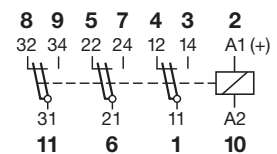

### Fig. 1 AC voltage endurance

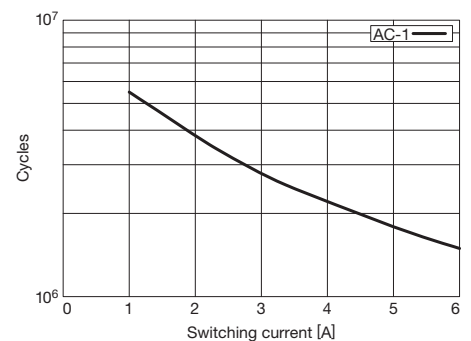

### Fig. 2 DC load limit curve

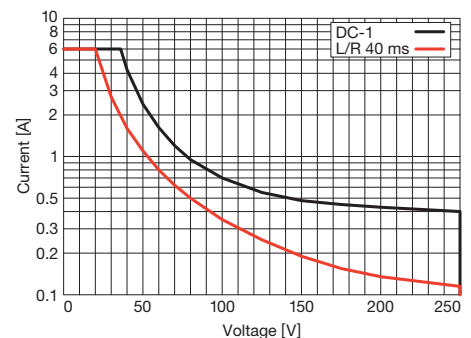

### Dimensions [mm]

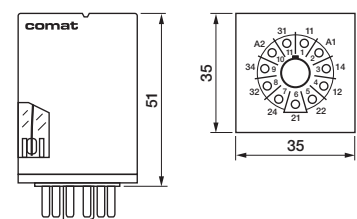

### Technical approvals, conformities

See table on page 53.

# R3-N3...

**11-pin plug-in relay, 3-pole, change-over contacts, according to IEC 60067**



**Type: R3-Nxx/...V**

Relays for Railway application, 3 change-over contacts

<b>Maximum contact load</b>	<b>6 A / 250 V AC-1, 6 A / 30 V DC-1</b>
<b>Recommended minimum contact load</b>	<b>10 mA / 10 V Code 4 5 mA / 5 V Code 8</b>

**Contacts**

Material	Optional	Code 4	AgNi + 0.2μ Au
	Optional	Code 8	AgNi + 10μ Au
Rated current			6 A
Inrush current max. (20 ms)			15 A
Switching voltage AC-1 max.			250 V
AC load max.			see Fig. 1
DC load max.			see Fig. 2

**Coil** (Values are valid at 20 °C)

Coil resistance	see table; tolerance ± 10 %
Operating voltage range	0.7 ... 1.25 U <sub>N</sub>
Nominal power	1.1 W

**Coil Table**

V DC	Ω	mA
<b>24</b>	525	46
<b>48</b>	2133	22
<b>72</b>	4844	15
<b>110</b>	12900	9

**Insulation**

Pulse (1.2 / 50 us / Dielectric strength (V rms, 1 minute)	
Contact / coil	4 kV / 2.5 kV
Contact / contact	4 kV / 2.5 kV
Contact open	1.5 kV / 1 kV

**Specifications**

Ambient temperature operation / storage	-25 (no ice) ... +70 °C / -40 ... +80 °C
Pick-up time / bounce time	18 ms / ≤ 3 ms
Release time / bounce time (D version)	35 ms / ≤ 1 ms
Mechanical life	> 10 millions
Ingress protection rating	IP 40
Weight	95 g

**Standard types**

**DC: 24, 48, 72, 110 V**

**Free wheeling diode**

**LED**

**LED + free wheeling diode**

<b>R3-N34/DC...V</b>	<b>R3-N38/DC...V</b>
<b>R3-N34D/DC...V</b>	<b>R3-N38D/DC...V</b>
<b>R3-N34X/DC...V</b>	<b>R3-N38X/DC...V</b>
<b>R3-N34DX/DC...V</b>	<b>R3-N38DX/DC...V*</b>

"..." Enter the voltage for full type designation

**Accessories**

Socket:	<b>C11A, C12B0</b>
Optional accessories (blanking plug):	<b>SO-NP, SO-OP</b>

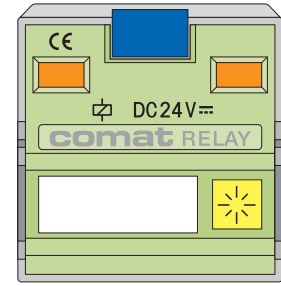

**Connection diagram**

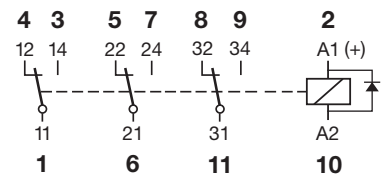

**Fig. 1 AC voltage endurance**

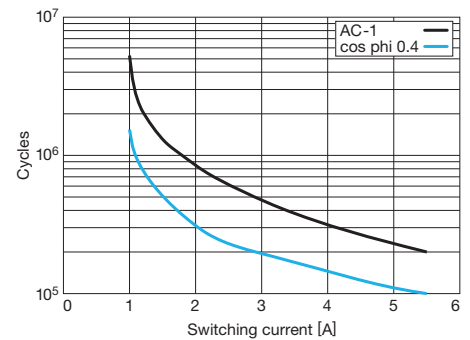

**Fig. 2 DC load limit curve**

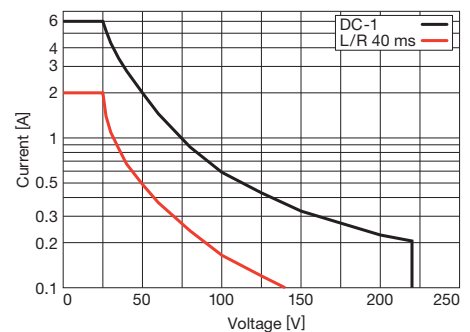

**Dimensions [mm]**

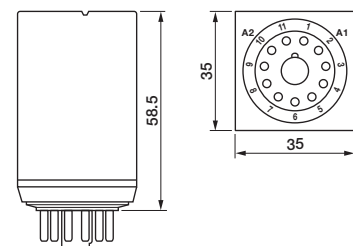

**Technical approvals, conformities**

See table on page 53.



Standard Relays

## R4-A4...

14-pin plug-in relay, 4-pole, change-over contacts

### Type: R4-A4xx/...V

Relays for Railway application, 4 change-over contacts

<b>Maximum contact load</b>	<b>6 A / 250 V AC-1, 0.5 A / 110 V DC-1</b> <b>6 A / 30 V DC-1, 0.2 A / 220 V DC-1</b>
<b>Recommended minimum contact load</b>	<b>10 mA / 10 V Code 4</b> <b>5 mA / 5 V Code 8</b>

### Contacts

Material	Optional	Code 4	AgNi + 0,2 μ Au
	Optional	Code 8	AgNi + 10 μ Au
Rated current			6 A
Inrush current max. (20 ms)			18 A
Switching voltage AC-1 max.			250 V
AC load max.			see Fig. 1
DC load max.			see Fig. 2

### Coil (Values are valid at 20 °C)

Coil resistance	see table; tolerance ± 10 %
Operating voltage range	0.7 ... 1.25 U <sub>N</sub>
Nominal power	1.4 W

### Coil Table

V DC	Ω	mA
24	426	56
36	881	41
48	1500	32
72	3456	21
110	8231	13

### Insulation

Pulse (1.2 / 50 us / Dielectric strength (V rms, 1 minute)	
Contact / coil	4 kV / 2.5 kV
Contact / contact	4 kV / 2.5 kV
Contact open	1.5 kV / 1 kV

### Specifications

Ambient temperature operation / storage	-25 (no ice) ... +55 °C / -40 ... +80 °C
Pick-up time / bounce time	15 ms / ≤ 2 ms
Release time / bounce time	20 ms / ≤ 2 ms
Mechanical life	> 20 millions
Ingress protection rating	IP40
Weight	90 g

### Standard types

**DC: 24, 36, 48, 72, 110 V**

**LED**

**Free wheeling diode**

**Polarity and free wheeling diode**

**R4-A44/DC...V**

**R4-A44X/DC...V**

**R4-A44DX/DC...V**

**R4-A44FX/DC...V**

**R4-A48/DC...V**

**R4-A48X/DC...V**

**R4-A48DX/DC...V**

**R4-A48FX/DC...V**

"..." Enter the voltage for full type designation

### Accessories

Socket:	<b>CS-144</b>
Optional accessories (blanking plug):	<b>SO-NP, SO-OP</b>

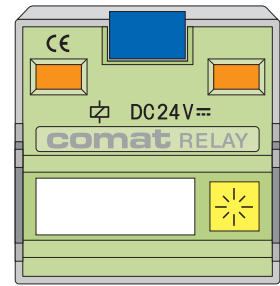

### Connection diagram

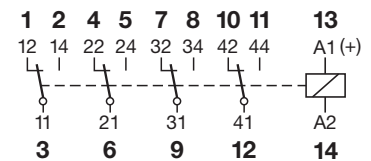

**Fig. 1 AC voltage endurance**

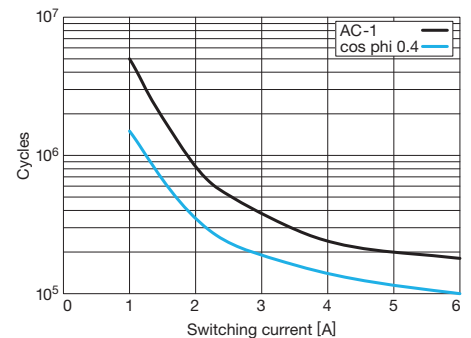

**Fig. 2 DC load limit curve**

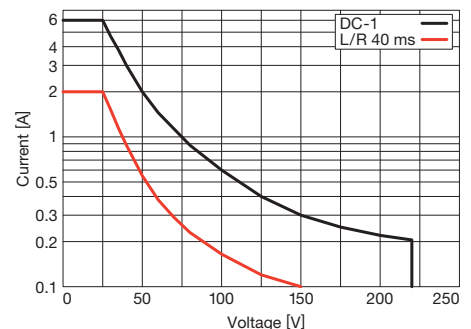

### Dimensions [mm]

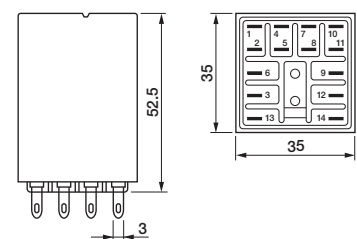

### Technical approvals, conformities

See table on page 53.

# R7-A2...

## 8-pin plug-in miniature relay, 2-pole, change-over contacts

### Type: R7-A2x/...V

Relays for Railway application, sensitive, 2 change-over contacts

<b>Maximum contact load:</b>	<b>10 A / 250 V AC-1, 10 A / 30 V DC-1</b>
<b>Recommended minimum contact load</b>	<b>10 mA / 10 V Code 4</b> <b>5 mA / 5 V Code 8</b>

### Contacts

Material	Optional	Code 4	AgNi + 0.2μ Au
	Optional	Code 8	AgNi + 10μ Au
Rated current			10 A
Inrush current max. (20 ms)			30 A
Switching voltage AC-1 max.			250 V
AC load max.			see Fig. 1
DC load max.			see Fig. 2

### Coil (Values are valid at 20 °C)

Coil resistance	see table; tolerance ±10 %
Operating voltage range	0.7 ... 1.25 U <sub>N</sub>
Nominal power	1.1 W

### Coil Table

V DC	Ω ±10%	mA
<b>24</b>	535	45
<b>48</b>	2004	24
<b>72</b>	4750	15
<b>110</b>	11337	10

### Insulation

Pulse (1.2 / 50 us / Dielectric strength (V rms, 1 minute)	
Contact / coil	4 kV / 2.5 kV
Contact / contact	4 kV / 2.5 kV
Contact open	1.5 kV / 1 kV

### Specifications

Ambient temperature operation / storage	-25 (no ice) ... +70 °C / -40 ... +80 °C
Number of mechanical operations	> 20 millions
Pick-up time typ.	10 ms
Release time typ.	15 ms
Ingress protection rating	IP40
Weight	35 g

### Standard types

**DC: 24, 48, 72, 110 V**

**LED:**

**Free wheeling diode:**

**LED + free wheeling diode:**

<b>R7-A24/DC...V</b>	<b>R7-A28/DC...V</b>
<b>R7-A24X/DC...V</b>	<b>R7-A28X/DC...V</b>
<b>R7-A24D/DC...V</b>	<b>R7-A28D/DC...V</b>
<b>R7-A24DX/DC...V</b>	<b>R7-A28DX/DC...V</b>

"..." Enter the voltage for full type designation

### Accessories

Socket: **CS-118**

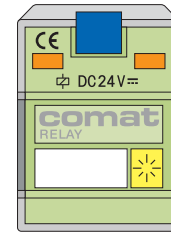

### Connection diagram

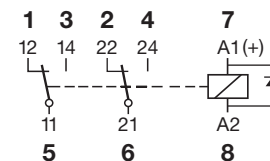

**Fig. 1 AC voltage endurance**

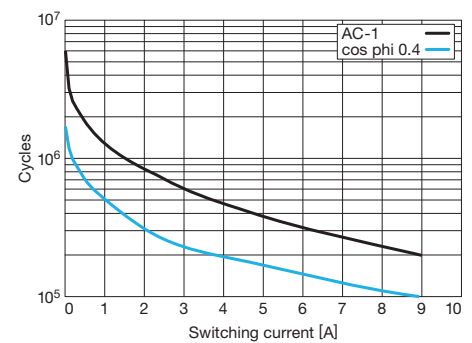

**Fig. 2 DC load limit curve**

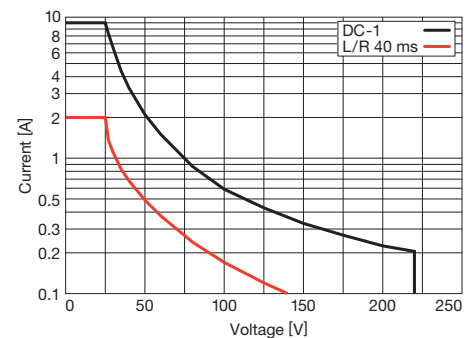

### Dimensions [mm]

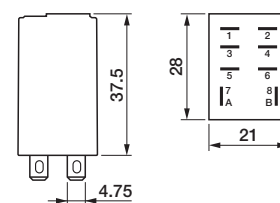

### Technical approvals, conformities

See table on page 53.

# R7-T2...

## 8-pin plug-in miniature relay, 2-pole, change-over twin contacts

### Type: R7-T2x/...V

Relays for Railway application, 2 change-over twin contacts

<b>Maximum contact load</b>	<b>6 A / 250 V AC-1, 6 A / 30 V DC-1</b>
<b>Recommended minimum contact load</b>	<b>5 mA / 5 V Code 1</b> <b>1 mA / 5 V Code 2</b>

### Contacts

Material	Standard	Code 1	AgNi + 0.2μ Au
	Optional	Code 2	AgNi + 10μ Au
Rated current	6 A		
Inrush current max. (20 ms)	15 A		
Switching voltage AC-1 max.	250 V		
AC load max.	see Fig. 1		
DC load max.	see Fig. 2		

### Coil

(Values are valid at 20 °C)

Coil resistance	see table; tolerance ± 10 %
Operating voltage range	0.7 ... 1.25 U <sub>N</sub>
Nominal power	1.1 W

### Coil Table

V DC	Ω ±10%	mA
<b>24</b>	535	45
<b>48</b>	2004	24
<b>72</b>	4750	15
<b>110</b>	11337	10

### Insulation

Pulse (1.2 / 50 us / Dielectric strength (V rms, 1 minute)

Contact / coil	4 kV / 2.5 kV
Contact / contact	4 kV / 2.5 kV
Contact open	1.5 kV / 1 kV

### Specifications

Ambient temperature operation / storage	-25 (no ice) ... +70 °C / -40 ... +80 °C
Number of mechanical operations	> 20 millions
Pick-up time typ.	10 ms
Release time typ.	15 ms
Ingress protection rating	IP40
Weight	35 g

### Standard types

**DC: 24, 48, 72, 110 V**

**LED:**

**Free wheeling diode:**

**LED + free wheeling diode:**

<b>R7-T21/DC...V</b>	<b>R7-T22/DC...V</b>
<b>R7-T21X/DC...V</b>	<b>R7-T22X/DC...V</b>
<b>R7-T21D/DC...V</b>	<b>R7-T22D/DC...V</b>
<b>R7-T21DX/DC...V</b>	<b>R7-T22DX/DC...V</b>

"..." Enter the voltage for full type designation

### Accessories

Socket: **CS-118**

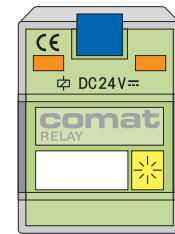

### Connection diagram

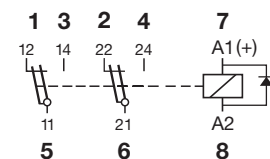

**Fig. 1 AC voltage endurance**

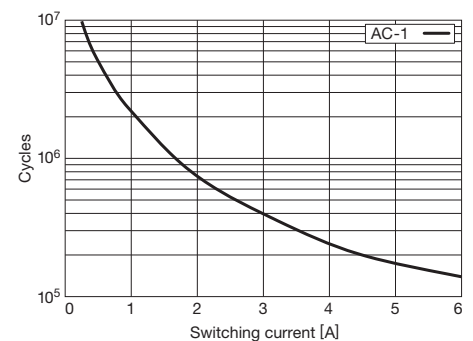

**Fig. 2 DC load limit curve**

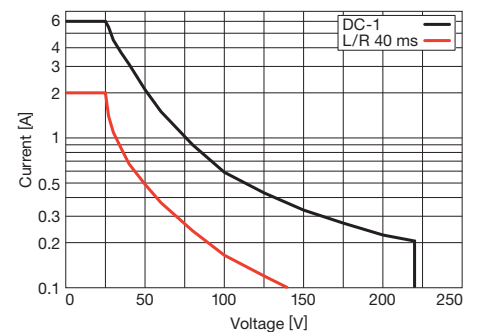

### Dimensions [mm]

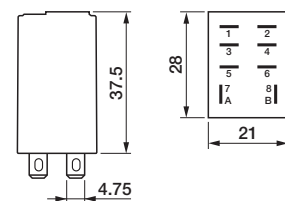

### Technical approvals, conformities

See table on page 53.

# CINT-21

## Interface module with mechanical change-over output contact, DIN rail mounting

### Types: CINT-21/...V

Standard interface module, 1 change-over contact  
 Cage clamp terminal  
 Control voltage UC 24 V, 50/60 Hz  
 Green LED for status indication

**Max. contact load** **6 A / 250 V AC-1**

### Contact Data

Type	micro disconnection
Material	AgSnO <sub>2</sub>
Rated current	6 A
Inrush current max. (5 ms)	30 A
Switching voltage AC-1 max.	250 V
AC load max.	1500 VA
DC load max.	see Fig. 2
Recommended min. contact load	10 mA / 12 V

**Control input V<sub>n</sub> = UC 24 V**

Operating voltage range	16.3 ... 30 V
Typical input current	11 mA
Nominal power consumption	260 mW

### Insulation

Pulse (1.2 / 50 us / Dielectric strength (V rms, 1 minute)	
Contact / coil	6 kV / 4 kV
Contact open	1.5 kV / 1 kV

### General Specifications

Ambient temperature operation / storage	-40 ... +70 °C / -40 ... +85 °C
Typical response time @ V <sub>n</sub>	5 ms
Typical release time @ V <sub>n</sub>	10 ms
Service life mech. / elec.	≥ 10 <sup>7</sup> / ≥ 10 <sup>5</sup> operations
Cond. cross section cage clamp terminal	stranded wire 0.5 ... 1.5 mm <sup>2</sup>
Ingress protection rating	IP 20
Mounting position	any
Housing material	Polyamid

### Standard types

**UC 24 (AC/DC):** **CINT-21/UC24V**

### Accessories

Plug-in bridges:	<b>CINT-BR20</b> (2 x 10 pin)
Label plate:	<b>CINT-BEZ/64</b> (64 pieces)
Replacement relay for CINT-21:	<b>CINT-R1/DC24V</b>

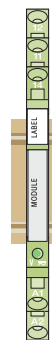

### Connection diagram

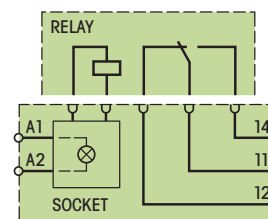

**Fig. 1 AC voltage endurance**

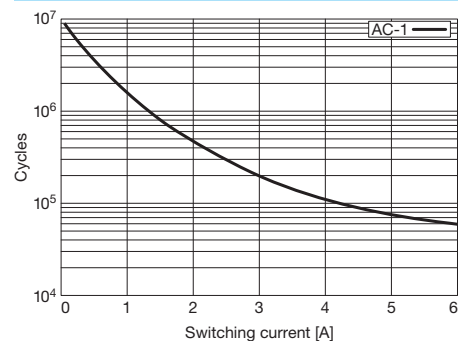

**Fig. 2 DC load limit curve**

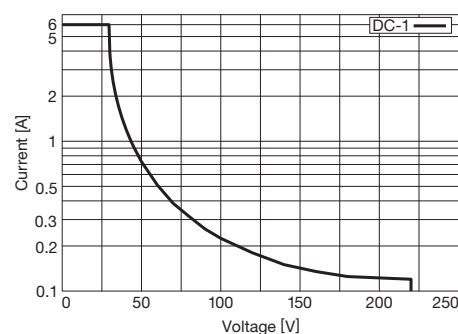

### Dimensions [mm]

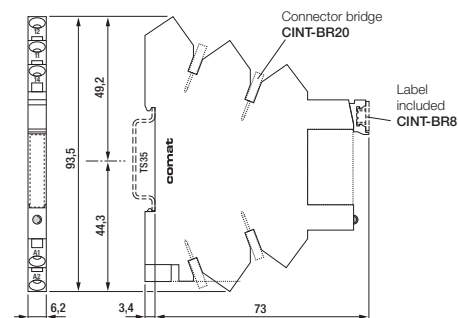

### Technical approvals, conformities

See table on page 53.

Interface relays 6.2 mm

## CINT-22

**Interface module with mechanical change-over output contact, DIN rail mounting**

### Types: CINT-22/UC24V

Standard interface module, 1 change-over contact  
 Cage clamp terminal  
 Control voltage UC 24 V, 50/60 Hz  
 Green LED for status indication

**Max. contact load** **6 A / 250 V AC-1**

### Contact Data

Type	micro disconnection
Material	AgNi +5μAu
Rated current	6 A
Inrush current max. (20 ms)	10 A
Switching voltage AC-1 max.	250 V
AC load max.	1500 VA
DC load max.	see Fig. 2
Recommended min. contact load	1 mA / 1 V

**Control input  $V_n =$**  **UC 24 V**

Operating voltage range	16.8 ... 30 V
Typical input current	11 mA
Nominal power consumption	260 mW

### Insulation

Pulse (1.2 / 50 us / Dielectric strength (V rms, 1 minute)	
Contact / coil	6 kV / 4 kV
Contact open	1.5 kV / 1 kV

### General Specifications

Ambient temperature operation / storage	-40 ... +70 °C / -40 ... +85 °C
Typical response time @ $V_n$	5 ms
Typical release time @ $V_n$	10 ms
Service life mech. / elec.	$\geq 10^7$ / $\geq 10^5$ operations
Cond. cross section cage clamp terminal	stranded wire 0.5 ... 1.5 mm <sup>2</sup>
Ingress protection rating	IP 20
Mounting position	any
Housing material	Polyamid

### Standard types

**UC 24 (AC/DC):** **CINT-22/UC24V**

### Accessories

Plug-in bridges:	<b>CINT-BR20</b> (2 x 10 pin)
Label plate:	<b>CINT-BEZ/64</b> (64 pieces)
Replacement relay for CINT-22:	<b>CINT-R2/DC24V</b>

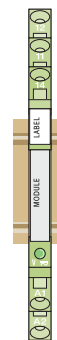

### Connection diagram

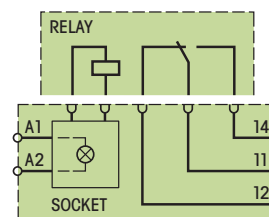

**Fig. 1 AC voltage endurance**

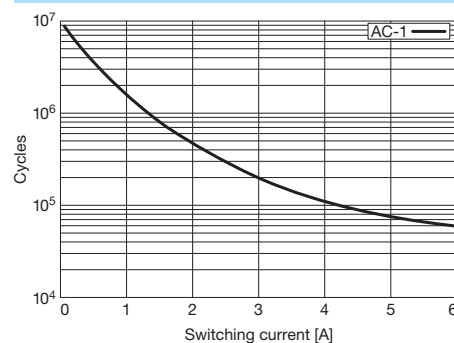

**Fig. 2 DC load limit curve**

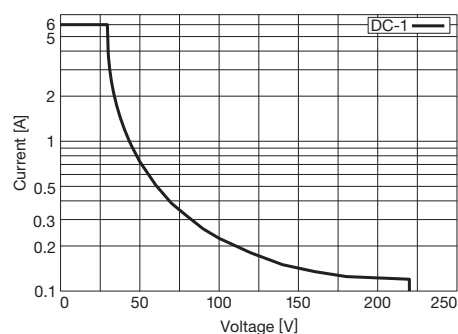

### Dimensions [mm]

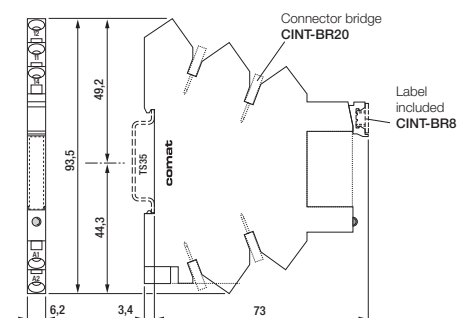

### Technical approvals, conformities

See table on page 53.

**CINT-25****Interface module with solide state DC output,  
DIN rail mounting****Types: CINT-25/UC24V**

Standard interface module, Solide state DC

Cage clamp terminal

Control voltage UC 24 V, 50/60 Hz

Green LED for status indication

**Max. contact load** **2 A / 24 V DC-1****Contact Data**

Type	micro disconnection
Material	Solide state
Rated current	2 A
Inrush current max. (10 ms)	20 A
Switching voltage DC-1 max.	30 V
DC load max.	48 W
Recommended min. contact load	1 mA, 6 V

**Control input V<sub>n</sub> = UC 24 V**

Operating voltage range	16.8 ... 30 V
Typical input current	11 mA
Nominal power consumption	260 mW

**Insulation**

Pulse (1.2 / 50 us / Dielectric strength (V rms, 1 minute)

Input / output - / 2.5 kV

**General Specifications**

Ambient temperature operation / storage	-40 ... +55 °C / -40 ... +85 °C
Typical response time @ V <sub>n</sub>	1 ms
Typical release time @ V <sub>n</sub>	1 ms
Cond. cross section cage clamp terminal	stranded wire 0.5 ... 1.5 mm <sup>2</sup>
Ingress protection rating	IP 20
Mounting position	any
Housing material	Polyamid

**Standard types****UC 24 (AC/DC):** **CINT-25/UC24V****Accessories**

Plug-in bridges:	<b>CINT-BR20</b> (2 x 10 pin)
Label plate:	<b>CINT-BEZ/64</b> (64 pieces)
Replacement relay for CINT-25:	<b>CINT-R5/DC24V</b>

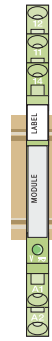
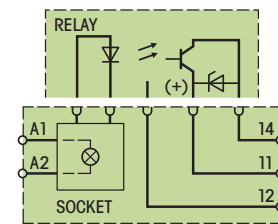
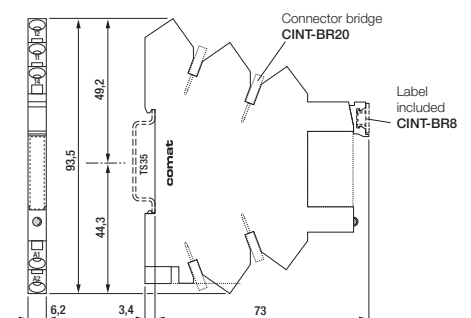
**Connection diagram****Dimensions [mm]****Technical approvals, conformities**

See table on page 53.

Interface relays 14 mm

## CINT-61

**Interface module with mechanical change-over output contact, DIN rail mounting**

### Types: CINT-61/UC24V

Standard interface module, 1 change-over contact  
Cage clamp terminal  
Control voltage UC 24 V, 50/60 Hz  
Green LED for status indication

**Max. contact load** **10 A / 250 V AC-1**

### Contact Data

Type	micro disconnection
Material	AgSnO <sub>2</sub>
Rated current	10 A / (16 A*)
Inrush current max. (5 ms)	80 A
Switching voltage AC-1 max.	250 V
AC load max.	4000 VA
DC load max.	see Fig. 2
Recommended min. contact load	10 mA, 24 V

\* For currents > 10 A, contact terminals must be connected in parallel (21 with 11, 24 with 14, 22 with 12)

**Control input V<sub>n</sub> =** **UC 24 V**

Operating voltage range	16.8 ... 30 V
Typical input current	20 mA
Nominal power consumption	480 mW

### Insulation

Pulse (1.2 / 50 us / Dielectric strength (V rms, 1 minute)	
Contact / coil	6 kV / 4 kV
Contact open	1.5 kV / 1 kV

### General Specifications

Ambient temperature operation / storage	-40 ... +70 °C / -40 ... +85 °C
Typical response time @ V <sub>n</sub>	5 ms
Typical release time @ V <sub>n</sub>	10 ms
Service life mech. / elec.	≥ 10 <sup>7</sup> / ≥ 10 <sup>5</sup> operations
Cond. cross section cage clamp terminal	stranded wire 0.5 ... 1.5 mm <sup>2</sup>
Ingress protection rating	IP 20
Mounting position	any
Housing material	Polyamid

### Standard types

**UC 24 (AC/DC):** **CINT-61/UC24V**

### Accessories

Plug-in bridges:	<b>CINT-BR8/5</b> (5 pieces x 8 pin)
Label plate:	<b>CINT5-BEZ/18</b> (18 pieces)
Replacement relay for CINT-61:	<b>CINT-R21/DC24V</b>

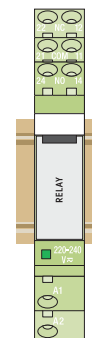

### Connection diagram

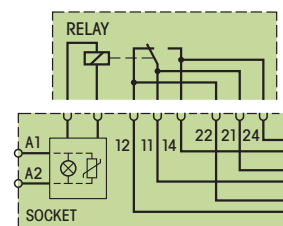

**Fig. 1 AC voltage endurance**

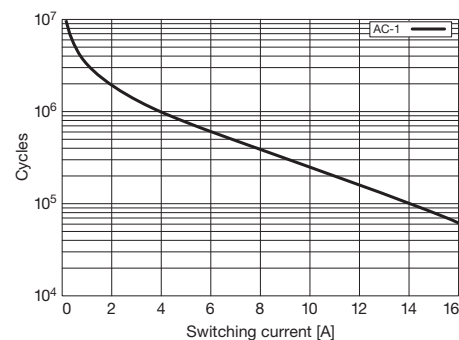

**Fig. 2 DC load limit curve**

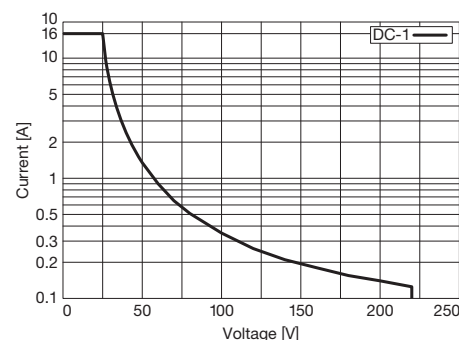

### Dimensions [mm]

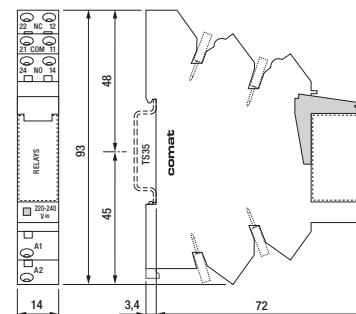

### Technical approvals, conformities

See table on page 53.

## CINT-62

### Interface module with 2 mechanical change-over output contacts, DIN rail mounting

#### Types: CINT-62/UC24V

Standard interface module, 1 change-over contact

Cage clamp terminal

Control voltage UC 24 V, 50/60 Hz

Green LED for status indication

**Max. contact load** **8 A / 250 V AC-1**

#### Contact Data

Type	micro disconnection
Material	AgNi + 5µAu
Rated current	8 A
Inrush current max. (20 ms)	15 A
Switching voltage AC-1 max.	250 V
AC load max.	2000 VA
DC load max.	see Fig. 2
Recommended min. contact load	5 mA / 5 V

<b>Control input V<sub>n</sub> =</b>	<b>UC 24 V</b>
Operating voltage range	16.8 ... 30 V
Typical input current	20 mA
Nominal power consumption	480 mW

#### Insulation

Pulse (1.2 / 50 us / Dielectric strength (V rms, 1 minute)	
Contact / coil	6 kV / 4 kV
Contact / contact	4 kV / 2 kV
Contact open	1.5 kV / 1 kV

#### General Specifications

Ambient temperature operation / storage	-40 ... +70 °C / -40 ... +85 °C
Typical response time @ V <sub>n</sub>	5 ms
Typical release time @ V <sub>n</sub>	10 ms
Service life mech. / elec.	≥ 10 <sup>7</sup> / ≥ 10 <sup>5</sup> operations
Cond. cross section spring cage	stranded wire 0.5 ... 1.5 mm <sup>2</sup>
Ingress protection rating	IP 20
Mounting position	any
Housing material	Polyamid

#### Standard types

**UC 24 (AC/DC):** **CINT-62/UC24V**

#### Accessories

Plug-in bridges:	<b>CINT-BR8/5</b> (5 pieces x 8 pin)
Label plate:	<b>CINT5-BEZ/18</b> (18 pieces)
Replacement relay for CINT-62:	<b>CINT-R22/DC24V</b>

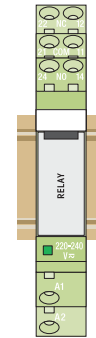

**Connection diagram**

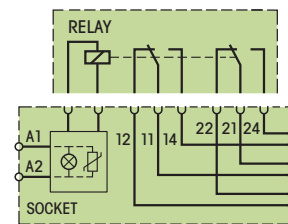

**Fig. 1 AC voltage endurance**

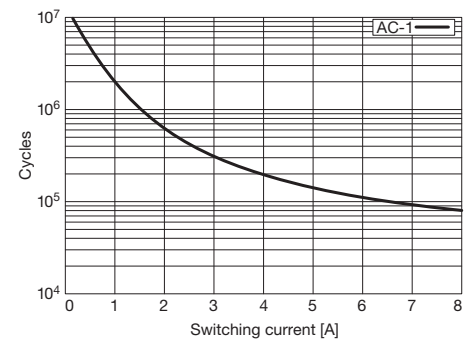

**Fig. 2 DC load limit curve**

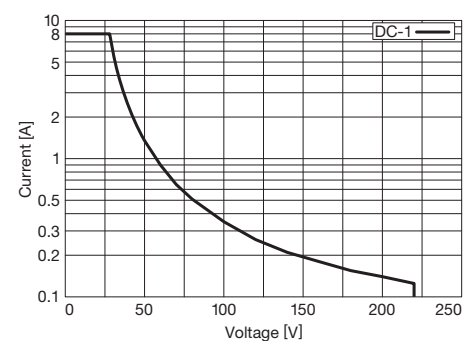

#### Dimensions [mm]

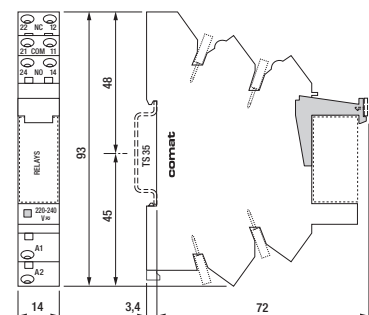

#### Technical approvals, conformities

See table on page 53.



Interface relays 14 mm

**CINT-63**
**Interface module with 2 mechanical change-over output contacts, DIN rail mounting**
**Types: CINT-63/UC24V**

 Standard interface module, 1 change-over contact  
 Cage clamp terminal  
 Control voltage UC 24 V, 50/60 Hz  
 Green LED for status indication

**Max. contact load** **8 A / 250 V AC-1**
**Contact Data**

Type	micro disconnection
Material	AgNi
Rated current	8 A
Inrush current max. (20 ms)	15 A
Switching voltage AC-1 max.	250 V
AC load max.	2000 VA
DC load max.	see Fig. 2
Recommended min. contact load	10 mA / 24 V

**Control input  $V_n =$**  **UC 24 V**

Operating voltage range	16.8 ... 30 V
Typical input current	20 mA
Nominal power consumption	480 mW

**Insulation**

Pulse (1.2 / 50 us / Dielectric strength (V rms, 1 minute)	
Contact / coil	6 kV / 4 kV
Contact / contact	4 kV / 2 kV
Contact open	1.5 kV / 1 kV

**General Specifications**

Ambient temperature operation / storage	-40 ... +70 °C / -40 ... +85 °C
Typical response time @ $V_n$	5 ms
Typical release time @ $V_n$	10 ms
Service life mech. / elec.	$\geq 10^7$ / $\geq 10^5$ operations
Cond. cross section cage clamp terminal	stranded wire 0.5 ... 1.5 mm <sup>2</sup>
Ingress protection rating	IP 20
Mounting position	any
Housing material	Polyamid

**Standard types**
**UC 24 (AC/DC):** **CINT-63/UC24V**
**Accessories**

Plug-in bridges:	<b>CINT-BR8/5</b> (5 pieces x 8 pin)
Label plate:	<b>CINT5-BEZ/18</b> (18 pieces)
Replacement relay for CINT-63:	<b>CINT-R23/DC24V</b>

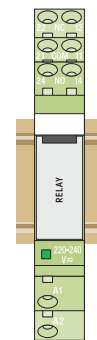
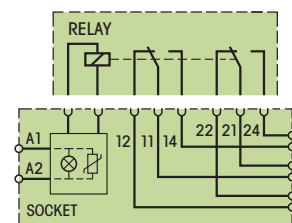
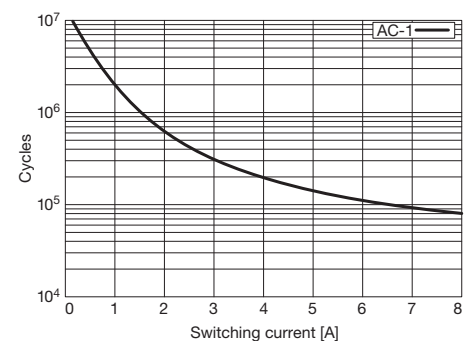
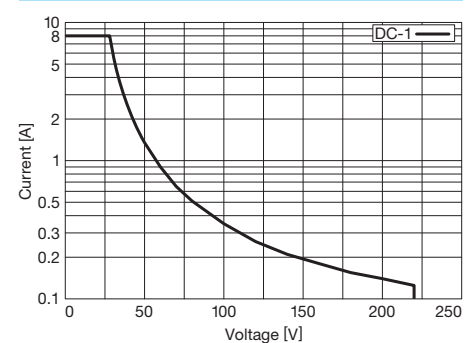
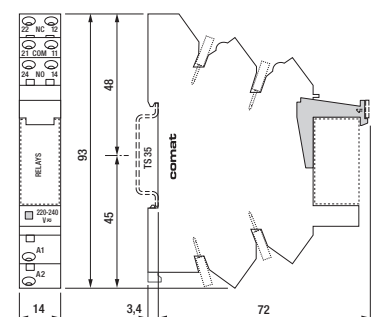
**Connection diagram**

**Fig. 1 AC voltage endurance**

**Fig. 2 DC load limit curve**

**Dimensions [mm]**

**Technical approvals, conformities**

See table on page 53.

**C203.06R****Interface module with 2 mechanical change-over twin contacts,  
DIN rail mounting****Types: 203.06R/...V**

Standard interface module, 2 separate change-over contacts

Screw terminals

Control voltage UC 24 or 36 V, 50/60 Hz

LED status indicator for each channel

Sealed relays built in

Also suitable for panel mounting 2 x M4

**Max. contact load** **2 A / 30 V DC-1****Contact Data**

Type	twin contacts
Material	Ag +Au
Rated current	2 A
Switching voltage AC-1 max.	125 V
AC load max.	100 VA
DC load max.	see Fig. 2
Recommended min. contact load	10 µA / 10 mV

**Control input  $V_n =$** 

	<b>UC 24 V</b>	<b>UC 36 V</b>
Operating voltage range	16.8 ... 30 V	25.2 ... 45 V
Typical input current	18 mA	9 mA
Nominal power consumption (per channel)	220 mW	330 mW

**Insulation**

Contact / Coil 2.5 kVrms 1 minute

**General Specifications**

Ambient temperature operation / storage	-40 ... +70 °C / -40 ... +85 °C
Typical response time @ $V_n$	10 ms
Typical release time @ $V_n$	20 ms
Service life mech. / elec.	$\geq 10^7$ / $\geq 10^5$ operations
Cond. cross section screw terminal	stranded wire 2.5 mm <sup>2</sup> , 2 x 1.5 mm <sup>2</sup>
Ingress protection rating	IP 20
Max. screw torque	0.4 Nm
Mounting position	any
Housing material	Lexan
Weight	80 g

**Standard types****UC (AC DC): 24, 36 V****C203.06R/UC...V**

"... " Enter the voltage for full type designation

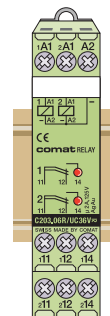
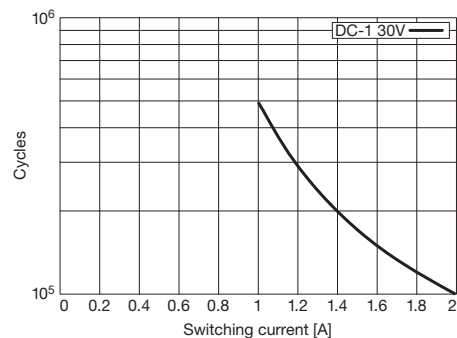
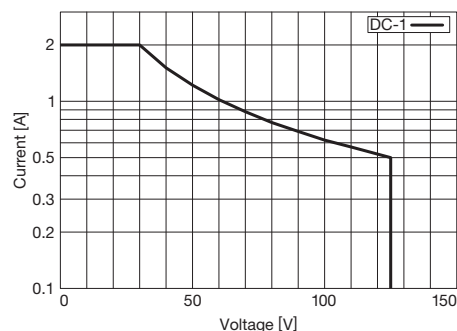
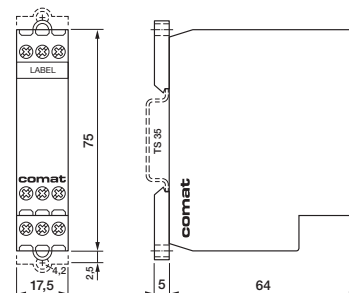
**Accessories**Label plate: **BZS-DIN17.5****Connection diagram****Fig. 1 DC voltage endurance****Fig. 2 DC load limit curve****Dimensions [mm]****Technical approvals, conformities**

See table on page 53.

Power relays

## RIC20-...

**20 A, AC/DC control voltage, silent operation,  
DIN rail mounting according to DIN 43 880**

**Type: RIC20-xxx/...V**

Hum-free installation contactor, 2 contacts, 2 NO, 1 NO-1 NC, 2 NC types available

**Rated operational power** 4 kW / 230 V AC-1, 0.5 A / 220 V DC-1  
**Recommended minimum contact load** 10 mA / 24 V

### Contacts

Material	AgNi
Rated current	20 A
Inrush current max. (100 ms)	50 A
Switching voltage AC-1 max.	400 V
AC load max. AC-1, AC-7a	4 kW / 230 V
AC-3	1.3 kW /230 V (NO contact only)
DC load max.	see Fig. 1

### Control input $V_n =$

	UC 24 V	UC 36 V	UC 230 V
Operating voltage range [V]	20.4 ... 26.4	30.6 ... 39.6	195 ... 253
Typ. pick up voltage [V]	17	25	160
Typ. release voltage [V]	7	11	70
Power consumption [W]	≤ 2.5	≤ 2.5	≤ 2.5
Inductive turn-off voltage	None	None	None
Surge immunity EN 61000-4-5	2 kV	2 kV	2 kV

### Insulation

Rated insulation voltage	230 V
Rated impulse withstand voltage	4 kV
Min. clearance of open contact	3.6 mm

### General Specifications

Ambient temperature storage	-30 ... +80 °C
operation, Spacer after 2 contactors side by side	-5 ... +55 °C
operation, Spacer after 3 contactors side by side	-5 ... +40 °C
Pick-up time	15 ... 45 ms
Release time	20 ... 50 ms
Mechanical life	≥ 3 x 10 <sup>6</sup> operations
AC voltage endurance at rated load AC-3, AC-7b	≥ 3 x 10 <sup>5</sup> operations
DC voltage endurance at rated load DC-1	10 <sup>5</sup> operations
Operating frequency at rated load DC-1	≤ 300 operations / h
Operating frequency at rated load AC-1	≤ 600 operations / h
Conductor cross section coil /contacts	Stranded wire 2.5 mm <sup>2</sup> / 6 mm <sup>2</sup>
Max. Screw torque coil / contacts	0.6 Nm / 1.2 Nm
Ingress protection rating	IP 20
Weight	140 g

### Standard types

<b>UC (AC/DC) 50/60 Hz: 24, 36, 230 V</b>	<b>2NO:</b> RIC20-200/UC ...V
	<b>1NO + 1NC:</b> RIC20-110/UC ...V
"..." Enter the voltage for full type designation	<b>2NC:</b> RIC20-020/UC ...V

### Accessories

Auxiliary contact bloc:	<b>RIC-AUX...</b>
Sealing cover:	<b>RIC-SEAL20</b>
Spacer:	<b>RIC-DIST</b>

### Samples of lamp loads

	Number of lamps
Incandescent lamps 230 V / 100 W	20
Fluorescent lamps not corrected 230 V / 36 W	17
Fluorescent lamps electronic ballast units 36 W	15

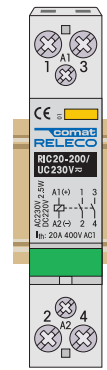

### Connection diagram

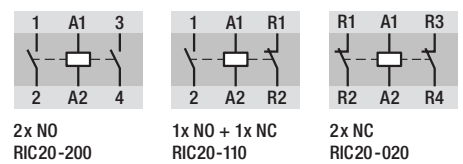

### Coil circuit

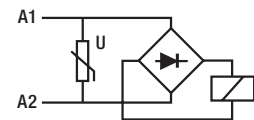

**Fig. 1 DC load limit curve DC-1**

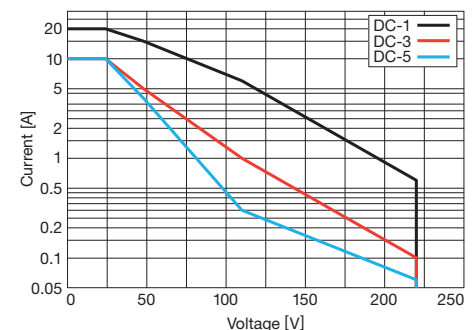

### Dimensions [mm]

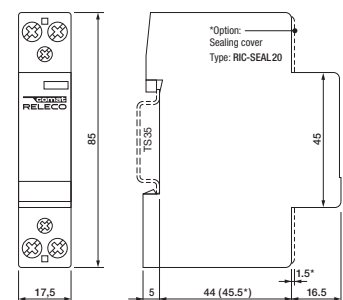

### Mounting information

If multiple contactors are mounted side by side, spacers (RIC DIST) have to be inserted for the purpose of heat dissipation.

**Example:** Ambient temperature up to 40°C: 1 spacer after 3 RIC // 40...55°C: 1 spacer after 2 RIC.

### Technical approvals, conformities

See table on page 53.

Power relays

## RIC25-...

**25 A, AC/DC control voltage, silent operation  
DIN Rail mounting according to DIN 43 880**

**Type: RIC25-xxx/...V**

Hum-free installation contactor, 4 contacts, 4 NO, 4 NC, 2 NO-2 NC types available

**Rated operational power AC-1**                      **Single phase: 5.4 kW/230 V, 0.5 A/220 V DC-1**  
**3 phase 230 V: 9 kW**  
**3 phase 400 V: 16 kW**

**Recommended minimum contact load**                      **10 mA / 24 V**

### Contacts

Material	AgNi
Rated current	25 A
Inrush current max. (100 ms)	50 A
Switching voltage AC-1 max.	400 V
AC load max. AC-1, AC-7a	4 kW / 230 V
AC-3	2.2 kW / 230 V, 4 kW / 400 V
DC load max.	see Fig. 1

### Control input V<sub>n</sub> =

	UC 24 V	UC 36 V	UC 230 V
Operating voltage range [V]	20.4 ... 26.4	30.6 ... 39.6	195 ... 253
Typ. pick up voltage [V]	17	25	160
Typ. release voltage [V]	7	11	70
Power consumption [W]	≤ 3	≤ 3	≤ 3
Inductive turn-off voltage	None	None	None
Surge immunity EN 61000-4-5	2 kV	2 kV	2 kV

### Insulation

Rated insulation voltage	440 V
Rated impulse withstand voltage	4 kV
Min. clearance of open contact	3.6 mm

### General Specifications

Ambient temperature storage	-30 ... +80 °C
operation, Spacer after 2 contactors side by side	-5 ... +55 °C
operation, Spacer after 3 contactors side by side	-5 ... +40 °C
Pick-up time	15 ... 45 ms
Release time	20 ... 70 ms
Mechanical life	≥ 3 x 10 <sup>6</sup> operations
AC voltage endurance at rated load AC-3, AC-7b	≥ 5 x 10 <sup>5</sup> operations
DC voltage endurance at rated load DC-1	10 <sup>5</sup> operations
Operating frequency at rated load DC-1	≤ 300 operations / h
Operating frequency at rated load AC-1, AC-3	≤ 600 operations / h
Conductor cross section coil / contacts terminals	Stranded wire 2.5 mm <sup>2</sup> / 6 mm <sup>2</sup>
Max. Screw torque coil / contacts	0.6 Nm / 1.2 Nm
Ingress protection rating	IP 20
Weight	270 g

### Standard types

<b>UC (AC/DC) 50/60 Hz: 24, 36, 230 V</b>	<b>4NO:</b> <b>RIC25-400/UC...V</b>
	<b>2NO + 2NC:</b> <b>RIC25-220/UC...V</b>
	<b>4NC:</b> <b>RIC25-040/UC...V</b>

"..." Enter the voltage for full type designation

### Accessories

Auxiliary contact bloc:	<b>RIC-AUX...</b>
Sealing cover:	<b>RIC-SEAL25</b>
Spacer:	<b>RIC-DIST</b>

### Samples of lamp loads

Samples of lamp loads	Number of lamps
Incandescent lamps 230 V/ 100 W	20
Fluorescent lamps not corrected 230 V/ 36 W	20
Fluorescent lamps electronic ballast units 36 W	20

### Mounting information

If multiple contactors are mounted side by side, spacers (RIC DIST) have to be inserted for the purpose of heat dissipation.

**Example:** Ambient temperature up to 40°C: 1 spacer after 3 RIC // 40...55°C: 1 spacer after 2 RIC.

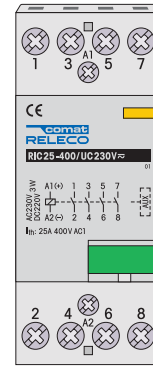

### Connection diagram

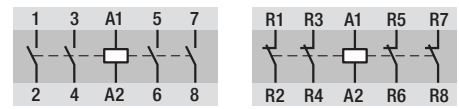

4x NO: RIC25-400

4x NC: RIC25-040

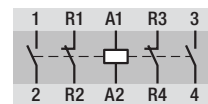

2x NO + 2x NC: RIC25-220

### Coil circuit

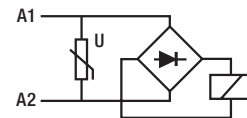

**Fig. 1 DC load limit curve DC-1**

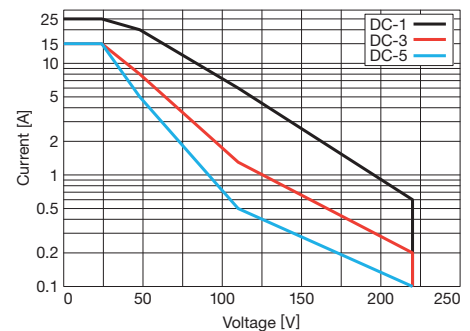

### Dimensions [mm]

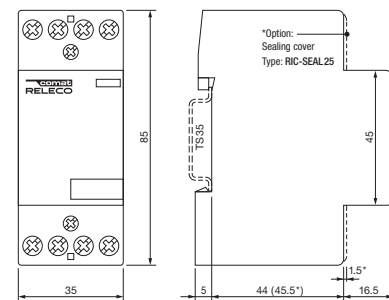

### Technical approvals, conformities

See table on page 53.

## 2. Time Relays

### ◉ TF-60 Setting of long times

The TF60 time setting method permits short examination of long delay time settings. Elapsing times of hours can be monitored in the sec. range.

#### Example for a delay time of 38h:

1. Set range switch to 60sec
  2. Set 38sec on the potentiometer (e.g. check 38sec by chronometer)
  3. Set range switch to 60h
- The delay time now amounts to 38h.

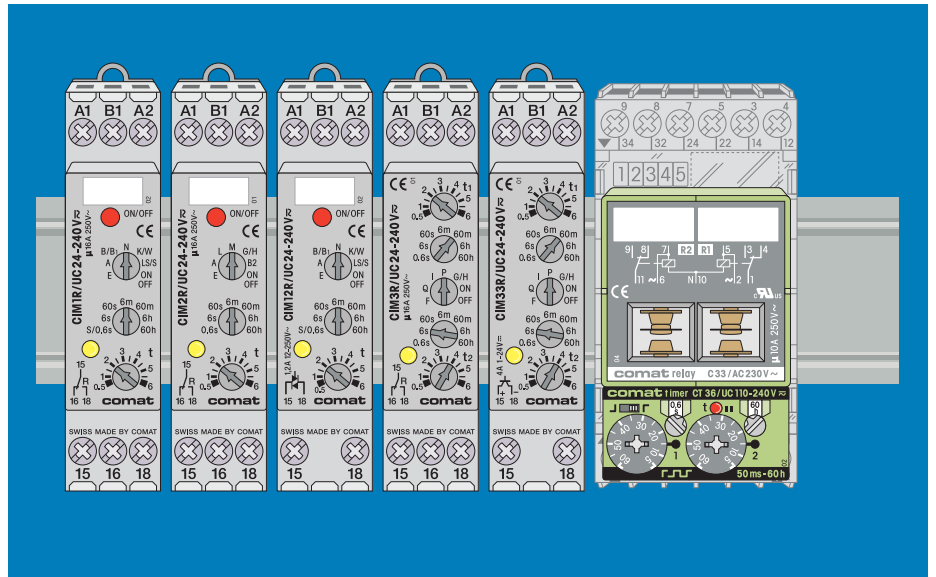

Application	Types	Functions*	t min. – max.	Output contacts	Design
Time relay with mechanical CO output contact	<b>CIM1R</b>	E, A, W, N, K, B, B1, S, LS	50 ms – 60 h <sup>◉</sup>	16 A 250 V	
Time relay with AC solide-state output	<b>CIM12R</b>	E, A, W, N, K, B, B1, S, LS	50 ms – 60 h <sup>◉</sup>	2 A 250 V	
Time relay with DC solide-state output	<b>CIM13R</b>	E, A, W, N, K, B, B1, S, LS	50 ms – 60 h <sup>◉</sup>	5 A 24 V <sup>==</sup>	
Time relay with mechanical CO output contact	<b>CIM2R</b>	E, A, L, M, B2, G, H	50 ms – 60 h <sup>◉</sup>	16 A 250 V	
Time relay with AC solide-state output	<b>CIM22R</b>	E, A, L, M, B2, G, H	50 ms – 60 h <sup>◉</sup>	2 A 250 V	
Time relay with AC solide-state output	<b>CIM23R</b>	E, A, L, M, B2, G, H	50 ms – 60 h <sup>◉</sup>	5 A 24 V <sup>==</sup>	
Time relay with mechanical CO output contact	<b>CIM3R</b>	F, Q, G, H, I, P	50 ms – 60 h <sup>◉</sup>	16 A 250 V	
Time relay with AC solide-state output	<b>CIM32R</b>	F, Q, G, H, I, P	50 ms – 60 h <sup>◉</sup>	2 A 250 V	
Time relay with DC solide-state output	<b>CIM33R</b>	F, Q, G, H, I, P	50 ms – 60 h <sup>◉</sup>	5 A 24 V <sup>==</sup>	
Modular time relay with power CO output contacts	<b>CT32.31</b>	E, A, W, N, K, B, B1	0.15 s – 60 min	10 A	
Modular time relay with 3 twin CO output contacts	<b>CT32.32</b>	E, A, W, N, K, B, B1	0.15 s – 60 min	6 A	
Modular time relay with power CO output contacts	<b>CT33.31</b>	E, A, F, W, N, Q, K, L, B, B1, G, H	30 ms – 60 h <sup>◉</sup>	10 A	
Modular time relay with 3 twin CO output contacts	<b>CT33.32</b>	E, A, F, W, N, Q, K, L, B, B1, G, H	30 ms – 60 h <sup>◉</sup>	6 A	
Modular time relay with power CO output contacts	<b>CT36.31</b>	I, P	2x 50 ms – 60 h <sup>◉</sup>	10 A	
Modular time relay with 3 twin CO output contacts	<b>CT36.32</b>	I, P	2x 50 ms – 60 h <sup>◉</sup>	6 A	

\*Function diagrams: refer to page 20

## Delay functions

**E On delay**  
  
 S ⇒ R on with delay  
 S OFF ⇒ R off

**A Off delay**  
  
 S ⇒ R on  
 S OFF ⇒ R off with delay

**F On and off delay**  
  
 S ⇒ R on with delay (t1)  
 S OFF ⇒ R off with delay (t2)

## Shot timing modes

**W One shot leading edge**  
  
 S ⇒ R on for t  
 S OFF ⇒ R off  
 (pulse clipping)

**N One shot trailing edge**  
  
 S OFF ⇒ R on for t  
 S on for t ⇒ R off

**Q One shot leading and trailing edge**  
  
 S ⇒ R on for t1  
 S OFF ⇒ R on for t2  
 S OFF off for t1 ⇒ R off

## Puls shaping

**K Puls shaping**  
  
 S (pulse or continuous contact) ⇒ R on for t  
 S... no influence on R and t

**L Pulse shaping, retrigger (subsequ.time operation from 0)**  
  
 S (pulse or continuous contact) ⇒ R on for t  
 S on for t = tRESET

**M Puls shaping**  
  
 S OFF ⇒ R on for t  
 S... no influence on R and t

## Blinker functions

**B Blinker, pulse start**  
  
 S ⇒ R on/off periodically according to t  
 S OFF ⇒ R off

**B1 Blinker, pulse start, trailing pulse**  
  
 S ⇒ R on/off periodically according to t  
 S OFF: last pulse = t

**B2 Blinker, interval start**  
  
 S ⇒ R after t on/off periodically according to t  
 S OFF ⇒ R off

## Delayed pulse

**G On delay single shot**  
  
 S (pulse or continuous contact) ⇒ R after t1 on for t2  
 S... no influence on R and t

**H On delay single shot**  
  
 S ⇒ R after t1 on for t2  
 S OFF ⇒ R off

## Repeat cycle timer

**I Repeat cycle timer, pulse start**  
  
 S ⇒ R on/off periodically according to t1 and t2  
 S OFF ⇒ R off

**P Repeat cycle timer, interval start** **C55, CT1: t2 t1**  
  
 S ⇒ R after t1 (t2) on/off periodically according to t2 and t1  
 S OFF ⇒ R off

## Special functions

**Y Star-delta timer**  
  
 S ⇒ R on for t  
 R OFF ⇒ Δ on with delay for t Δ  
 S OFF ⇒ Δ off

**X1 Restart delay**  
  
 S ⇒ R on  
 S OFF ⇒ R off and starts t  
 S ⇒ R restart only after t

## Special functions

**S Step-on / Step-off switch**  
  
 S ⇒ R on/off

**LS Step-switching (staircase lighting timer), with time lapse**  
  
 S ⇒ R on and starts t  
 S on for t ⇒ R off

## Stop / Reset

**tSTOP** SSTOP interrupts t (t-addition)      **T** t is stopped ⇒ R on/off

**tRESET** SRESET reset t t restarts immediately      **T** Test

S = Triggering  
 R = Output circuit  
 ⇒ = switches...

## CIM1R

### Time relay with mechanical change-over output contact

### 8 time functions + stepping function, ON-OFF switch, 50 ms ... 60 h

#### Type: CIM1R/UC24-240V

Sophisticated multifunction time relay, 1 change-over power contact with zero crossing switching (50/60 Hz), 8 time functions, stepping function and service function ON/OFF, time ranges: 50 ms ... 60 h, multifunction LED state indicator, suitable for any time-control application and also staircase lighting, Light-switch neon lamp current absorption on input B1, Manual switching function for maintenance, emergency, etc., 16.6 Hz power supply applications. Railway version available.

<b>Maximum contact load</b>	<b>16 A / 250 V AC-1</b>
<b>Recommended minimum contact load</b>	<b>10 mA / 10 V</b>

#### Time functions and related connection diagrams (Function diagrams: refer to page 20)

The functions are selectable by rotary switch

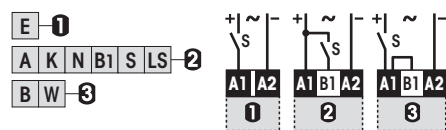

LED function table:

LED	Relay	Time run
OFF	OFF	NO
Continuous ON	ON	NO
Short blinking	OFF	YES
Long blinking	ON	YES

#### Time data

7 partial time ranges, $t_{max}$ (rotary switch)	0.6, 6, 60 s / 6, 60 min / 6, 60 h
Fine adjustment range (rotary knob)	$t_{min} \dots t_{max}$ , 0.5 ... 6
Time range tolerance	$t_{min}$ : -5 % ... +0 % / $t_{max}$ : -0 % ... +5 %
Repetition accuracy	± 0.1 % or DC: 2 ms / AC: 10 ms
Response time, power on, on A1	≤ 45 ms
Min. trigger pulse on B1	20 ms (AC / DC)
Reset time B1 (AC/DC)	≤ 40 ms
Voltage failure buffering (50 / 60 Hz)	≥ 20 ms

#### Contacts

Type	AgNi / 1 CO, micro disconnection
Rated operational current at 40 °C / 60 °C	16 A / 13 A
Max. inrush current (10 ms)	30 A
Max. switching voltage AC-1	250 V
Max. AC load AC-1 (Fig.1)	4 kVA
Max. DC load DC-1	see Fig. 2

#### Power supply- and control input

Nominal voltage (A1, B1)	<b>UC 24-240 V (UC = AC/DC)</b>
Operating voltage range	UC 16.8 ... 250 V
Power consumption	approx. 0.5 W
Frequency range	16 ... 63 Hz
Allowed DC residual current into B1	≤ 0.5 mA
AC Neon lamp residual current into B1	≤ 10 mA
Trigger threshold voltage on B1, AC / DC	13 / 15 V

#### Insulation

Test voltage open contact	1 kVrms 1 minute
Test voltage between contacts and control input	2.5 kVrms 1 minute

#### General Specifications

Ambient temperature storage / operation	-40 ... +85 °C / -40 ... +70 °C
Mechanical life of contact	30 x 10 <sup>6</sup> operations
Conductor cross section	Stranded wire 2.5 mm <sup>2</sup> , 2 x 1.5 mm <sup>2</sup>
Ingress protection rating	IP 20
Max. Screw torque	0.4 Nm
Housing material	Lexan
Weight	70 g

#### Standard types

UC (AC/DC) 15...60 Hz

**CIM1R/UC24-240V**

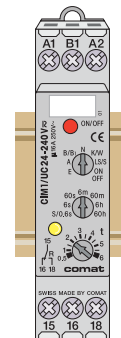

#### Connection diagram

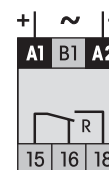

Fig. 1 AC voltage endurance

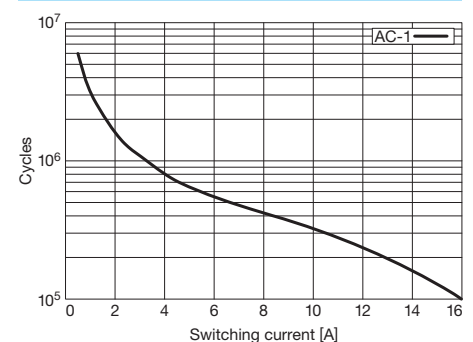
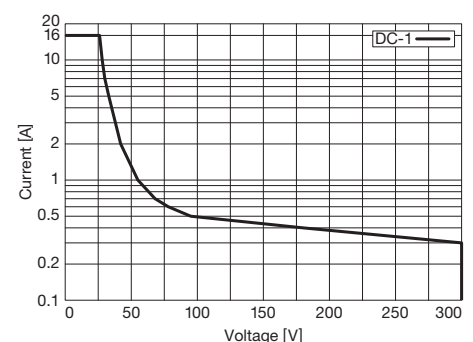
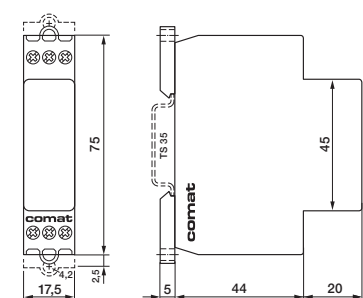

Fig. 2 DC load limit curve



#### Dimensions [mm]



#### Technical approvals, conformities

See table on page 53.

# CIM12R

## Time relay with AC solid-state output

### 8 time functions and stepping function, ON-OFF switch, 50 ms ... 60 h

**Type: CIMR12R/UC24-240V**

Sophisticated multifunction time relay, 1 triac output, suitable for high frequency of operations and inductive loads, 8 time functions, stepping function and service function ON/OFF, time ranges: 50 ms ... 60 h, multifunction LED state indicator, suitable for any time-control application and also staircase lighting, Light-switch neon lamp current absorption on input B1, manual switching function for maintenance, emergency, etc., 16.6 Hz applications. Railway version available.

**Maximum contact load** 2 A / 250 V

**Minimum contact load** 50 mA

**Time functions and related connection diagrams** (Function diagrams: refer to page 20)

The functions are selectable by rotary switch

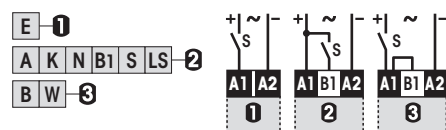

**LED function table:**

LED	Relay	Time run
OFF	OFF	NO
Continuous ON	ON	NO
Short blinking	OFF	YES
Long blinking	ON	YES

### Time data

7 partial time ranges, $t_{max}$ (rotary switch)	0.6, 6, 60 s / 6, 60 min / 6, 60 h
Fine adjustment range (rotary knob)	$t_{min} \dots t_{max}$ , 0.5 ... 6
Time range tolerance	$t_{min}$ : -5 % ... +0 % / $t_{max}$ : -0 % ... +5 %
Repetition accuracy	$\pm 0.1$ % or DC: 2 ms / AC: 10 ms
Response time, power on, on A1	$\leq 45$ ms
Min. trigger pulse on B1	20 ms (AC / DC)
Reset time B1 (AC/DC)	$\leq 40$ ms
Voltage failure buffering (50 / 60 Hz)	$\geq 20$ ms

### Output

Type	Triac, zero crossing
Rated operational current at 40 °C (Fig.1)	2 A
Max. inrush current (10 ms)	100 A
Max. switching voltage	250 V
Max. AC load AC-1	300 VA
$I^2t$ value	78 A <sup>2</sup> s
Leakage current	< 1 mA

### Power supply- and control input

Nominal voltage	<b>UC 24-240 V (UC = AC/DC)</b>
Operating voltage range	UC 16.8 ... 250 V
Power consumption	approx. 0.5 W
Frequency range	16 ... 63 Hz
Allowed DC residual current into B1	$\leq 0.5$ mA
AC Neon lamp residual current into B1	$\leq 10$ mA
Trigger threshold voltage on B1, AC / DC	13 / 15 V

### Insulation

Test voltage between output and control input	2.5 kVrms 1 minute
---	--------------------

### General Specifications

Ambient temperature storage / operation	-40 ... +85 °C / -40 ... +70 °C
Conductor cross section	Stranded wire 2.5 mm <sup>2</sup> , 2 x 1.5 mm <sup>2</sup>
Ingress protection rating	IP 20
Max. Screw torque	0.4 Nm
Housing material	Lexan
Weight	70 g

Standard types

**UC (AC/DC), 15...60 Hz**

**CIM12R/UC24-240V**

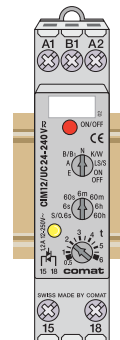

### Connection diagram

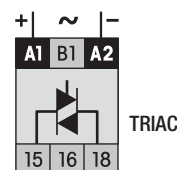

**Fig. 1 Output derating curve**

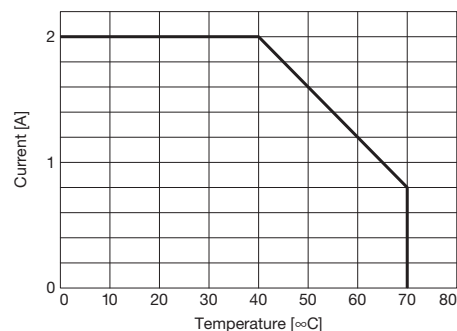

### Dimensions [mm]

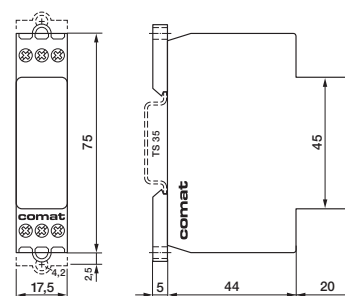

### Technical approvals, conformities

See table on page 53.



# CIM13R

## Time relay with DC solid-state output

### 8 time functions and stepping function, ON-OFF switch, 50 ms ... 60 h

**Type: CIM13R/UC24-240V**

Sophisticated multifunction time relay, 1 transistor output, 8 time functions, stepping function and service function ON/OFF, time ranges from 50 ms ... 60 h, multifunction LED state indicator, suitable for any time-control application and also staircase-light control, light-switch neon lamp current absorption on input B1, manual switching function for maintenance, emergency, etc., 16.6 Hz applications. Railway version available.

**Maximum contact load** 5 A / 30 V  
**Recommended minimum contact load** 1 mA

**Time functions and related connection diagrams** (Function diagrams: refer to page 20)

The functions are selectable by rotary switch

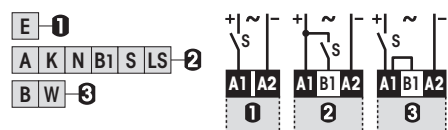

**LED function table:**

LED	Relay	Time run
OFF	OFF	NO
Continuous ON	ON	NO
Short blinking	OFF	YES
Long blinking	ON	YES

#### Time data

7 partial time ranges, $t_{max}$ (rotary switch)	0.6, 6, 60 s / 6, 60 min / 6, 60 h
Fine adjustment range (rotary knob)	$t_{min} \dots t_{max}, 0.5 \dots 6$
Time range tolerance	$t_{min}: -5 \% \dots +0 \% / t_{max}: -0 \% \dots +5 \%$
Repetition accuracy	$\pm 0.1 \%$ or DC: 2 ms / AC: 10 ms
Response time, power on, on A1	$\leq 45$ ms
Min. trigger pulse on B1	20 ms (AC / DC)
Reset time B1 (AC/DC)	$\leq 40$ ms
Voltage failure buffering (50 / 60 Hz)	$\geq 20$ ms

#### Output

Type	MOS FET
Rated operational current at 40 °C (Fig.1)	5 A
Max. inrush current (10 $\mu$ s)	40 A
Max. switching voltage	30 V
Leakage current	$< 10 \mu$ A

#### Power supply- and control input

Nominal voltage (UC = AC / DC)	<b>UC 24-240 V (UC = AC/DC)</b>
Operating voltage range	UC 16.8 ... 250 V
Power consumption	approx. 0.5 W
Frequency range	16 ... 63 Hz
Allowed DC residual current into B1	$\leq 0.5$ mA
AC Neon lamp residual current into B1	$\leq 10$ mA
Trigger threshold voltage on B1, AC / DC	13 / 15 V

#### Insulation

Test voltage between output and control input	2.5 kVrms 1 minute
---	--------------------

#### General Specifications

Ambient temperature storage / operation	-40 ... +85 °C / -40 ... +70 °C
Conductor cross section	Stranded wire 2.5 mm <sup>2</sup> , 2 x 1.5 mm <sup>2</sup>
Ingress protection rating	IP 20
Max. Screw torque	0.4 Nm
Housing material	Lexan
Weight	70 g

Standard types

**UC (AC/DC), 15...60 Hz**

**CIM13R/UC24-240V**

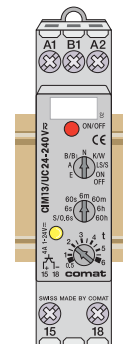

#### Connection diagram

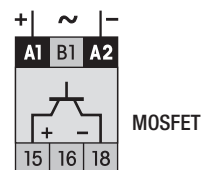

**Fig. 1 Output derating curve**

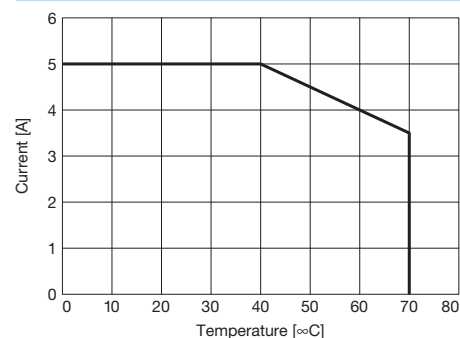

#### Dimensions [mm]

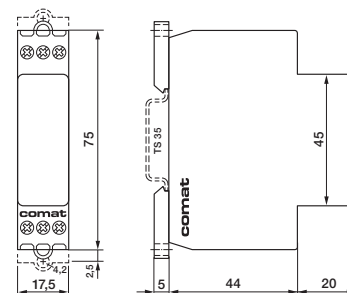

#### Technical approvals, conformities

See table on page 53.

# CIM2R

## Time relay with mechanical change-over output contact 7 time functions and 7 time ranges from 50 ms ... 60 h

**Type: CIM2R/UC24-240V**

Sophisticated multifunction time relay, 1 change-over power contact switching in zero crossing (50/60 Hz), 7 time functions and service function ON/OFF, 7 time ranges from 50 ms to 60 h, multifunction LED state indicator, suitable for any time-control application, light-switch neon lamp current absorption on input B1, manual switching function for maintenance, emergency, etc., 16.6 Hz power supply applications. Railway version available.

**Maximum contact load** 16 A / 250 V AC-1  
**Recommended minimum contact load** 10 mA / 10 V

**Time functions and related connection diagrams** (Function diagrams: refer to page 20)  
The functions are selectable by rotary switch

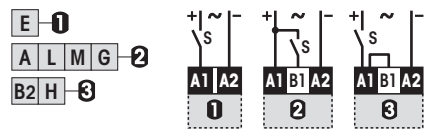

**LED function table:**

LED	Relay	Time run
OFF	OFF	NO
Continuous ON	ON	NO
Short blinking	OFF	YES
Long blinking	ON	YES

### Time data

7 partial time ranges,  $t_{max}$  (rotary switch) 0.6, 6, 60 s / 6, 60 min / 6, 60 h  
Fine adjustment range (rotary knob)  $t_{min} \dots t_{max}$ , 0.5 ... 6  
Time range tolerance  $t_{min}$ : -5 % ... +0 % /  $t_{max}$ : -0 % ... +5 %  
Repetition accuracy  $\pm 0.1$  % or DC: 2 ms / AC: 10 ms  
Response time, power on, on A1  $\leq 45$  ms  
Min. trigger pulse on B1 20 ms (AC / DC)  
Reset time B1 (AC/DC)  $\leq 40$  ms  
Voltage failure buffering (50 / 60 Hz)  $\geq 20$  ms

### Contacts

Type AgNi / 1 CO, micro disconnection  
Rated operational current at 40 °C / 60 °C 16 A / 13 A  
Max. inrush current (10 ms) 30 A  
Max. switching voltage AC-1 250 V  
Max. AC load AC-1 (Fig.1) 4 kVA  
Max. DC load DC-1 see Fig. 2

### Power supply- and control input

Nominal voltage (A1, B1) **UC 24-240 V (UC = AC / DC)**  
Operating voltage range UC 16.8 ... 250 V  
Power consumption approx. 0.5 W  
Frequency range 16 ... 63 Hz  
Allowed DC residual current into B1  $\leq 0.5$  mA  
AC Neon lamp residual current into B1  $\leq 10$  mA  
Trigger threshold voltage on B1, AC / DC 13 / 15 V

### Insulation

Test voltage open contact 1 kVrms 1 minute  
Test voltage between contacts and control input 2.5 kVrms 1 minute

### General Specifications

Ambient temperature storage / operation -40 ... +85 °C / -40 ... +70 °C  
Mechanical life of contact 30 x 10<sup>6</sup> operations  
Conductor cross section Stranded wire 2.5 mm<sup>2</sup>, 2 x 1.5 mm<sup>2</sup>  
Ingress protection rating IP 20  
Max. Screw torque 0.4 Nm  
Housing material Lexan  
Weight 70 g

### Standard types

**UC (AC/DC) 15...60 Hz**

**CIM2R/UC24-240V**

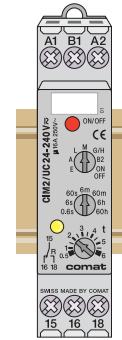

### Connection diagram

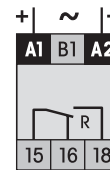

**Fig. 1 AC voltage endurance**

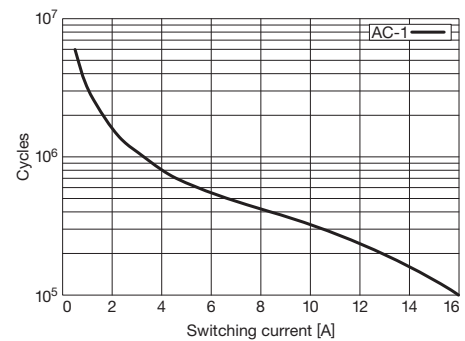

**Fig. 2 DC load limit curve**

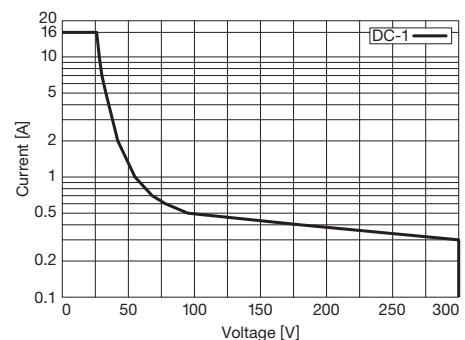

### Dimensions [mm]

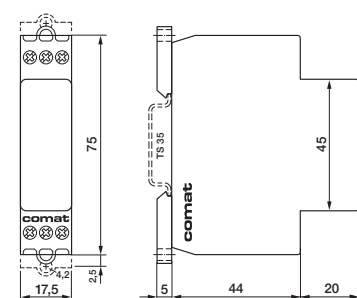

### Technical approvals, conformities

See table on page 53.

Multifunction Timer, DIN Rail mounting

## CIM22R

### Time relay with AC solid-state output

### 7 time functions and 7 time ranges 50 ms ... 60 h

#### Type: CIM22R/UC24-240V

Sophisticated multifunction time relay, 1 triac output, suitable for high frequency of operations and inductive loads, 7 time functions and service function ON/OFF, 7 time ranges from 50 ms ... 60 h, multifunction LED state indicator, suitable for any time-control application light-switch neon lamp current absorption on input B1, manual switching function for maintenance, emergency, etc., 16.6 Hz applications. Railway version available.

<b>Maximum contact load</b>	<b>2 A / 250 V</b>
<b>Minimum contact load</b>	<b>50 mA</b>

#### Time functions and related connection diagrams (Function diagrams: refer to page 20)

The functions are selectable by rotary switch

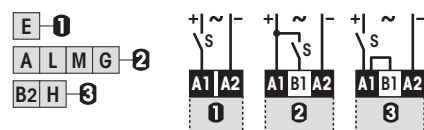

#### LED function table:

LED	Relay	Time run
OFF	OFF	NO
Continuous ON	ON	NO
Short blinking	OFF	YES
Long blinking	ON	YES

#### Time data

7 partial time ranges, $t_{max}$ (rotary switch)	0.6, 6, 60 s / 6, 60 min / 6, 60 h
Fine adjustment range (rotary knob)	$t_{min} \dots t_{max}$ , 0.5 ... 6
Time range tolerance	$t_{min}$ : -5 % ... +0 % / $t_{max}$ : -0 % ... +5 %
Repetition accuracy	$\pm 0.1$ % or DC: 2 ms / AC: 10 ms
Response time, power on, on A1	$\leq 45$ ms
Min. trigger pulse on B1	20 ms (AC / DC)
Reset time B1 (AC/DC)	$\leq 40$ ms
Voltage failure buffering (50 / 60 Hz)	$\geq 20$ ms

#### Output

Type	Triac, zero crossing
Rated operational current at 40 °C (Fig.1)	2 A
Max. inrush current (10 ms)	100 A
Max. switching voltage	250 V
Max. AC load AC-1	300 VA
$I^2t$ value	78 A <sup>2</sup> s
Leakage current	< 1 mA

#### Power supply- and control input

Nominal voltage	<b>UC 24-240 V (UC = AC / DC)</b>
Operating voltage range	UC 16.8 ... 250 V
Power consumption	approx. 0.5 W
Frequency range	16 ... 63 Hz
Allowed DC residual current into B1	$\leq 0.5$ mA
AC Neon lamp residual current into B1	$\leq 10$ mA
Trigger threshold voltage on B1, AC / DC	13 / 15 V

#### Insulation

Test voltage between output and control input	2.5 kVrms 1 minute
---	--------------------

#### General Specifications

Ambient temperature storage / operation	-40 ... +85 °C / -40 ... +70 °C
Conductor cross section	Stranded wire 2.5 mm <sup>2</sup> , 2 x 1.5 mm <sup>2</sup>
Ingress protection rating	IP 20
Max. Screw torque	0.4 Nm
Housing material	Lexan
Weight	70 g

#### Standard types

<b>UC (AC/DC), 15...60 Hz</b>	<b>CIM22R/UC24-240V</b>
-------------------------------	-------------------------

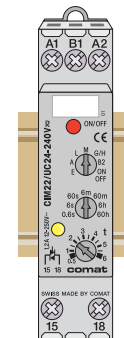

#### Connection diagram

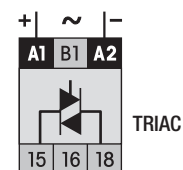
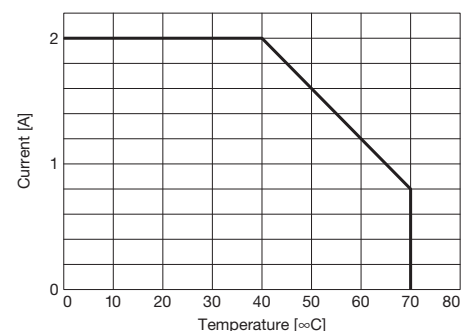
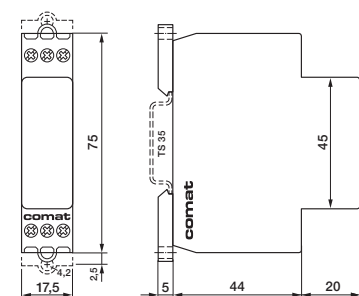

Fig. 1 Output derating curve



#### Dimensions [mm]



#### Technical approvals, conformities

See table on page 53.

# CIM23R

## Time relay with DC solid-state output

### 7 time functions and 7 time ranges from 50 ms ... 60 h

#### Type: CIM23R/UC24-240V

Sophisticated multifunction time relay, 1 transistor output, 7 time functions and service function ON/OFF, 7 time ranges from 50 ms ... 60 h, multifunction LED state indicator suitable for any time-control application, light-switch neon lamp current absorption on input B1, manual switching function for maintenance, emergency, etc., 16.6 Hz applications. Railway version available.

**Maximum contact load** 5 A / 30 V

**Recommended minimum contact load** 1 mA

#### Time functions and related connection diagrams (Function diagrams: refer to page 20)

The functions are selectable by rotary switch

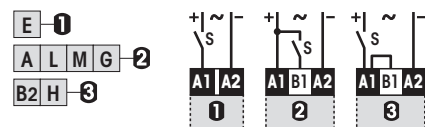

#### LED function table:

LED	Relay	Time run
OFF	OFF	NO
Continuous ON	ON	NO
Short blinking	OFF	YES
Long blinking	ON	YES

#### Time data

7 partial time ranges, $t_{max}$ (rotary switch)	0.6, 6, 60 s / 6, 60 min / 6, 60 h
Fine adjustment range (rotary knob)	$t_{min} \dots t_{max}, 0.5 \dots 6$
Time range tolerance	$t_{min}: -5\% \dots +0\% / t_{max}: -0\% \dots +5\%$
Repetition accuracy	$\pm 0.1\%$ or DC: 2 ms / AC: 10 ms
Response time, power on, on A1	$\leq 45$ ms
Min. trigger pulse on B1	20 ms (AC / DC)
Reset time B1 (AC/DC)	$\leq 40$ ms
Voltage failure buffering (50 / 60 Hz)	$\geq 20$ ms

#### Output

Type	MOS FET
Rated operational current at 40 °C (Fig.1))	5 A
Max. inrush current (10 $\mu$ s)	40 A
Max. switching voltage	30 V
Leakage current	$< 10 \mu$ A

#### Power supply- and control input

Nominal voltage (UC = AC / DC)	<b>UC 24-240 V (UC = AC / DC)</b>
Operating voltage range	UC 16.8 ... 250 V
Power consumption	approx. 0.5 W
Frequency range	16 ... 63 Hz
Allowed DC residual current into B1	$\leq 0.5$ mA
AC Neon lamp residual current into B1	$\leq 10$ mA
Trigger threshold voltage on B1, AC / DC	13 / 15 V

#### Insulation

Test voltage between output and control input	2.5 kVrms 1 minute
---	--------------------

#### General Specifications

Ambient temperature storage / operation	-40 ... +85 °C / -40 ... +70 °C
Conductor cross section	Stranded wire 2.5 mm <sup>2</sup> , 2 x 1.5 mm <sup>2</sup>
Ingress protection rating	IP 20
Max. Screw torque	0.4 Nm
Housing material	Lexan
Weight	70 g

#### Standard types

<b>UC (AC/DC), 15...60 Hz</b>	<b>CIM23R/UC24-240V</b>
-------------------------------	-------------------------

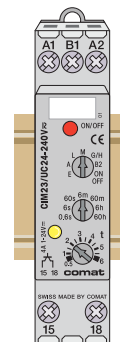

#### Connection diagram

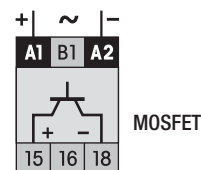

**Fig. 1 Output derating curve**

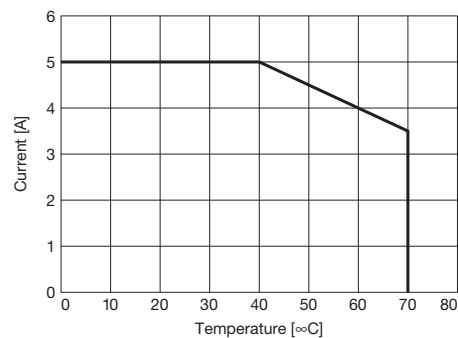

#### Dimensions [mm]

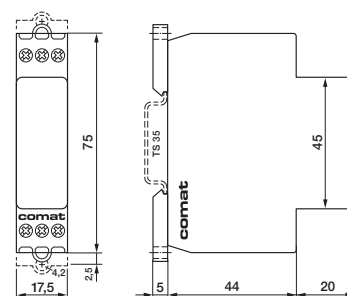

#### Technical approvals, conformities

See table on page 53.

## CIM3R

### Time relay with mechanical change-over output contact

### 6 time functions and service function, 7 time ranges from 50 ms...60 h

#### Type: CIM3R/UC24-240V

Sophisticated multifunction time relay, 1 change-over power contact switching in zero crossing (50/60 Hz), 6 time functions and service function ON/OFF, 7 time ranges from 50 ms to 60 h, multifunction LED state indicator, suitable for any time-control application, light-switch neon lamp current absorption on input B1, manual switching function for maintenance, emergency, etc., 16.6 Hz power supply applications. Railway version available.

<b>Maximum contact load</b>	<b>16 A / 250 V AC-1</b>
<b>Recommended minimum contact load</b>	<b>10 mA / 10 V</b>

#### Time functions and related connection diagrams (Function diagrams: refer to page 20)

The functions are selectable by rotary switch

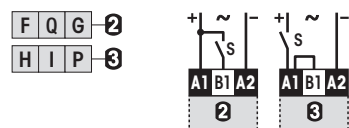

LED function table:

LED	Relay	Time run
OFF	OFF	NO
Continuous ON	ON	NO
Short blinking	OFF	YES
Long blinking	ON	YES

#### Time data

7 partial time ranges, $t_{max}$ (rotary switch)	0.6, 6, 60 s / 6, 60 min / 6, 60 h
Fine adjustment range (rotary knob)	$t_{min} \dots t_{max}$ , 0.5 ... 6
Time range tolerance	$t_{min}$ : -5 % ... +0 % / $t_{max}$ : -0 % ... +5 %
Repetition accuracy	$\pm 0.1$ % or DC: 2 ms / AC: 10 ms
Response time, power on, on A1	$\leq 45$ ms
Min. trigger pulse on B1	20 ms (AC / DC)
Reset time B1 (AC/DC)	$\leq 40$ ms
Voltage failure buffering (50 / 60 Hz)	$\geq 20$ ms

#### Contacts

Type	AgNi / 1 CO, micro disconnection
Rated operational current at 40 °C / 60 °C	16 A / 13 A
Max. inrush current (10 ms)	30 A
Max. switching voltage AC-1	250 V
Max. AC load AC-1 (Fig. 1)	4 kVA
Max. DC load DC-1	see Fig. 2

#### Power supply- and control input

Nominal voltage (A1, B1)	<b>UC 24-240 V (UC = AC / DC)</b>
Operating voltage range	UC 16.8 ... 250 V
Power consumption	approx. 0.5 W
Frequency range	16 ... 63 Hz
Allowed DC residual current into B1	$\leq 0.5$ mA
AC Neon lamp residual current into B1	$\leq 10$ mA
Trigger threshold voltage on B1, AC / DC	13 / 15 V

#### Insulation

Test voltage open contact	1 kVrms 1 minute
Test voltage between contacts and control input	2.5 kVrms 1 minute

#### General Specifications

Ambient temperature storage / operation	-40 ... +85 °C / -40 ... +70 °C
Mechanical life of contact	$30 \times 10^6$ operations
Conductor cross section	Stranded wire 2.5 mm <sup>2</sup> , 2 x 1.5 mm <sup>2</sup>
Ingress protection rating	IP 20
Max. Screw torque	0.4 Nm
Housing material	Lexan
Weight	70 g

#### Standard types

UC (AC/DC) 15...60 Hz

**CIM3R/UC24-240V**

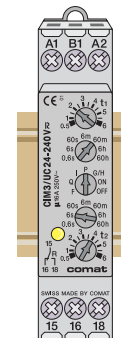

#### Connection diagram

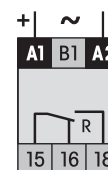

Fig. 1 AC voltage endurance

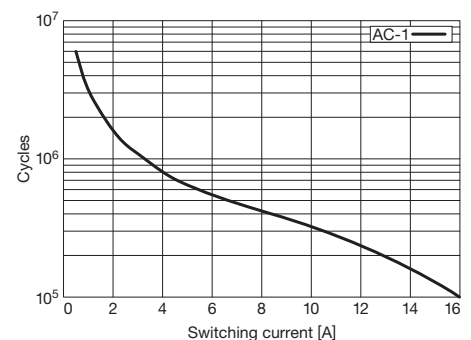
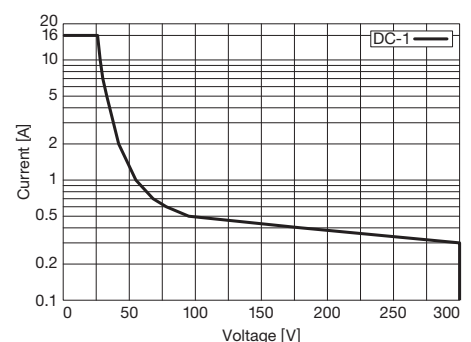
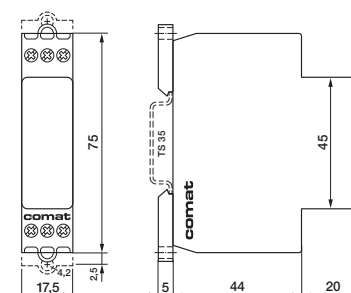

Fig. 2 DC load limit curve



#### Dimensions [mm]



#### Technical approvals, conformities

See table on page 53.

# CIM32R

## Time relay with AC solid-state output

### 6 time functions and service function, 7 time ranges from 50 ms...60 h

#### Type: CIM32R/UC24-240V

Sophisticated multifunction time relay, 1 triac output, suitable for high frequency of operations and inductive loads, 6 time functions and service function ON/OFF, 7 time ranges from 50 ms ... 60 h, multifunction LED state indicator, suitable for any time-control application light-switch neon lamp current absorption on input B1, manual switching function for maintenance, emergency, etc., 16.6 Hz applications. Railway version available.

<b>Maximum contact load</b>	<b>2 A / 250 V</b>
<b>Minimum contact load</b>	<b>50 mA</b>

#### Time functions and related connection diagrams (Function diagrams: refer to page 20)

The functions are selectable by rotary switch

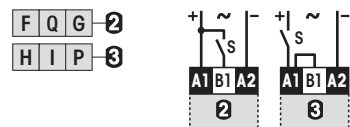

LED function table:

LED	Relay	Time run
OFF	OFF	NO
Continuous ON	ON	NO
Short blinking	OFF	YES
Long blinking	ON	YES

#### Time data

7 partial time ranges, $t_{max}$ (rotary switch)	0.6, 6, 60 s / 6, 60 min / 6, 60 h
Fine adjustment range (rotary knob)	$t_{min} \dots t_{max}, 0.5 \dots 6$
Time range tolerance	$t_{min}: -5 \% \dots +0 \% / t_{max}: -0 \% \dots +5 \%$
Repetition accuracy	$\pm 0.1 \%$ or DC: 2 ms / AC: 10 ms
Response time, power on, on A1	$\leq 45$ ms
Min. trigger pulse on B1	20 ms (AC / DC)
Reset time B1 (AC/DC)	$\leq 40$ ms
Voltage failure buffering (50 / 60 Hz)	$\geq 20$ ms

#### Output

Type	Triac, zero crossing
Rated operational current at 40 °C (Fig.1)	2 A
Max. inrush current (10 ms)	100 A
Max. switching voltage	250 V
Max. AC load AC-1	300 VA
$I^2t$ value	78 A <sup>2</sup> s
Leakage current	< 1 mA

#### Power supply- and control input

Nominal voltage	<b>UC 24-240 V (UC = AC / DC)</b>
Operating voltage range	UC 16.8 ... 250 V
Power consumption	approx. 0.5 W
Frequency range	16 ... 63 Hz
Allowed DC residual current into B1	$\leq 0.5$ mA
AC Neon lamp residual current into B1	$\leq 10$ mA
Trigger threshold voltage on B1, AC / DC	13 / 15 V

#### Insulation

Test voltage between output and control input	2.5 kVrms 1 minute
---	--------------------

#### General Specifications

Ambient temperature storage / operation	-40 ... +85 °C / -40 ... +70 °C
Conductor cross section	Stranded wire 2.5 mm <sup>2</sup> , 2 x 1.5 mm <sup>2</sup>
Ingress protection rating	IP 20
Max. Screw torque	0.4 Nm
Housing material	Lexan
Weight	70 g

#### Standard types

<b>UC (AC/DC), 15...60 Hz</b>	<b>CIM32R/UC24-240V</b>
-------------------------------	-------------------------

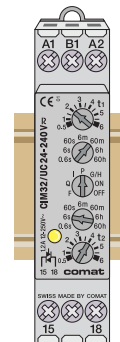

#### Connection diagram

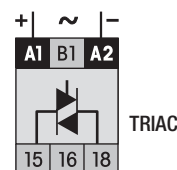
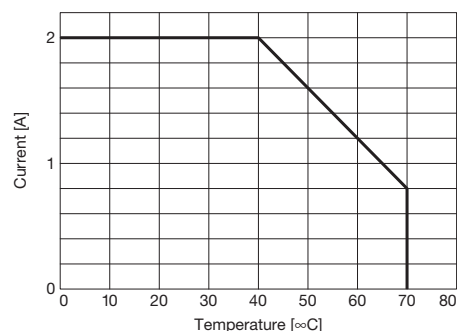
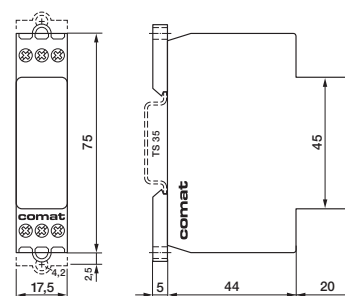

Fig. 1 Output derating curve



#### Dimensions [mm]



#### Technical approvals, conformities

See table on page 53.

# CIM33R

## Time relay with DC solid-state output

### 6 time functions and service function, 7 time ranges from 50 ms...60 h

**Type: CIM33/UC24-240V**

Sophisticated multifunction time relay, 1 transistor output, 6 time functions and service function ON/OFF, 7 time ranges from 50 ms ... 60 h, Multifunction LED state indicator, suitable for any time-control application, light-switch neon lamp current absorption on input B1, manual switching function for maintenance emergency, etc., 16.6 Hz applications. Railway version available.

**Maximum contact load** 5 A / 30 V  
**Recommended minimum contact load** 1 mA

**Time functions and related connection diagrams** (Function diagrams: refer to page 20)

The functions are selectable by rotary switch

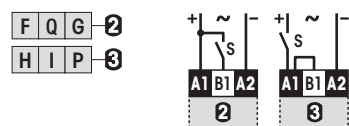

**LED function table:**

LED	Relay	Time run
OFF	OFF	NO
Continuous ON	ON	NO
Short blinking	OFF	YES
Long blinking	ON	YES

**Time data**

7 partial time ranges,  $t_{max}$  (rotary switch) 0.6, 6, 60 s / 6, 60 min / 6, 60 h  
 Fine adjustment range (rotary knob)  $t_{min} \dots t_{max}$ , 0.5 ... 6  
 Time range tolerance  $t_{min}$ : -5 % ... +0 % /  $t_{max}$ : -0 % ... +5 %  
 Repetition accuracy  $\pm 0.1$  % or DC: 2 ms / AC: 10 ms  
 Response time, power on, on A1  $\leq 45$  ms  
 Min. trigger pulse on B1 20 ms (AC / DC)  
 Reset time B1 (AC/DC)  $\leq 40$  ms  
 Voltage failure buffering (50 / 60 Hz)  $\geq 20$  ms

**Output**

Type MOS FET  
 Rated operational current at 40 °C (Fig.1) 5 A  
 Max. inrush current (10  $\mu$ s) 40 A  
 Max. switching voltage 30 V  
 Leakage current  $< 10 \mu$ A

**Power supply- and control input**

Nominal voltage **UC 24-240 V (UC = AC / DC)**  
 Operating voltage range UC 16.8 ... 250 V  
 Power consumption approx. 0.5 W  
 Frequency range 16 ... 63 Hz  
 Allowed DC residual current into B1  $\leq 0.5$  mA  
 AC Neon lamp residual current into B1  $\leq 10$  mA  
 Trigger threshold voltage on B1, AC / DC 13 / 15 V

**Insulation**

Test voltage between output and control input 2.5 kVrms 1 minute

**General Specifications**

Ambient temperature storage / operation -40 ... +85 °C / -40 ... +70 °C  
 Conductor cross section Stranded wire 2.5 mm<sup>2</sup>, 2 x 1.5 mm<sup>2</sup>  
 Ingress protection rating IP 20  
 Max. Screw torque 0.4 Nm  
 Housing material Lexan  
 Weight 70 g

**Standard types**

UC (AC/DC), 15...60 Hz

**CIM33R/UC24-240V**

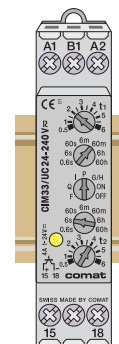

**Connection diagram**

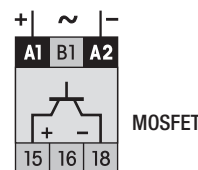

**Fig. 1 Output derating curve**

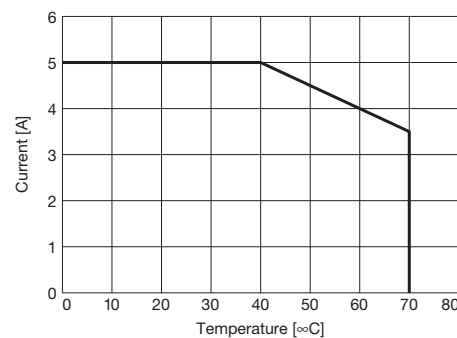

**Dimensions [mm]**

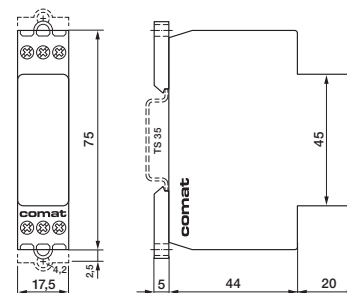

**Technical approvals, conformities**

See table on page 53.

**CT32R, CT33R, CT36R**

**Type CT32R, CT33R, CT36R, /...V**

Plug-in time modules for sockets with module slot in combination with plug-in relays.  
Power supply and control voltages 24 ... 240 V. Time ranges 30 ms up to 60 h.  
LED output state indicator.

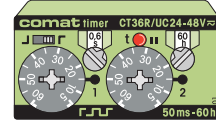

**Time functions and related connection diagrams** (Function diagrams: refer to page 20)

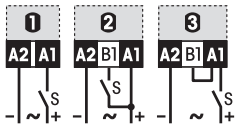

**CT32R** (Universal)

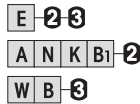

**CT33R** (Universal)



**CT36R** (Repeat cycle timer)



**Time data**

	<b>CT32R</b>	<b>CT33R</b>	<b>CT36R</b>
Type	<b>CT32R</b>	<b>CT33R</b>	<b>CT36R</b>
Partial time ranges, $t_{max}$	1.5, 6, 15, 60 /s /min	150, 600 ms 1.5, 6, 15, 60 /s /min /h	2 x 600 ms 2 x 6, 60 /s /min /h
Min. time $t_{min}$	0.15 s	30 ms	2 x 50 ms
Fine adj. range $t_{min}$ ...	1 ... 1 0	0.2 ... 1	2 x 5 ... 60
Time range tolerance	-25 ... 0 % 0 ... 25 %	-25 ... 0 % 0 ... 25 %	-25 ... 0 % 0 ... 25 %
Repetition accuracy	$\pm 0.2$ % or 20 ms	$\pm 0.2$ % or 20 ms	$\pm 0.2$ % or 20 ms
Temperature drift of time	0.1 % / K	0.1 % / K	0.1 % / K
Min. trigger pulse width B1	$\geq 30$ ms	$\geq 30$ ms	-
Reset time pow. supply	$\leq 150$ ms	$\leq 150$ ms	$\leq 150$ ms
Voltage failure buffering	$\geq 20$ ms	$\geq 20$ ms	$\geq 20$ ms

**Output data**

Nominal voltage	<b>UC 24-48 V</b>
Type	Solid state
Rated operational current	150 mA
On-state resistance	$\leq 25 \Omega$
Leakage current	$\leq 150 \mu A$

**Power supply and control input** (UC = AC/DC)

	<b>CT32R</b>	<b>CT33R</b>	<b>CT36R</b>
Type	<b>CT32R</b>	<b>CT33R</b>	<b>CT36R</b>
Nominal voltage	<b>UC 24 - 48 V</b>	<b>UC 24 - 48 V</b>	<b>UC 24 - 48 V</b>
Operating voltage range	16.8 ... 60 V	16.8 ... 60 V	16.8 ... 60 V
Input B1 inactive	$\leq 9$ V	$\leq 9$ V	-
Supply current	5 ... 11 mA	5 ... 11 mA	6 ... 12 mA

**General Specification**

Ambient temperature storage / operation	-40 ... +85 °C / -40 ... +70 °C
Ingress protection rating	IP 40 when plugged in
Housing material	Lexan
Weight	25 g

**Standard types**

**CT32R/UC24-48V**  
**CT33R/UC24-48V**  
**CT36R/UC24-48V**

**Remark:** This module is part of several ready for connection units consisting of socket, relay and module. A wide range of suitable relays are available.

**Dimensions [mm]**

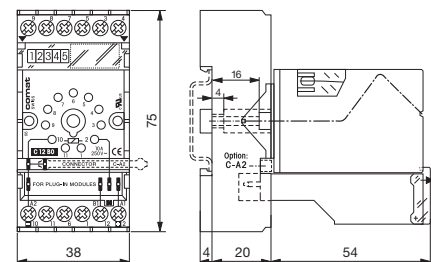

**Technical approvals, conformities**

See table on page 53.



**CT32.31R, CT33.31R, CT36.31R**  
**CT32.32R, CT33.32R, CT36.32R**

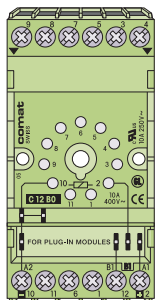

**Timer Delay Relay-Set**  
 Relay, Module and Socket

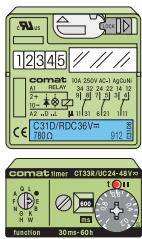

- Set delivery includes:
- Relay
  - Module
  - Front cover
  - Socket
  - Retaining clip



Relay data's see:  
 Relay C31; C32

**Timer-Modul**

**E 1** Triggering

Function (see page 30)

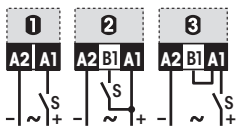

**Power Relay**

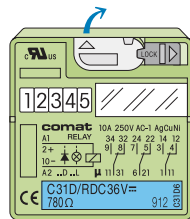
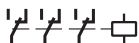

**C31D/R**

**Universal Power Relay 10A**  
 with 3 power change-over-contacts this is the robust relay for AC and DC circuits ranging from 50mA 10V.

**10A 250V~**  
 50mA 10V

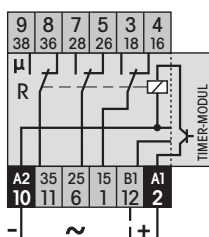

**Control Relay**

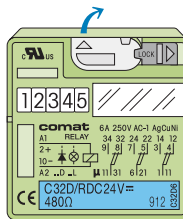

**C32D/R**

**Relay with 3 twin contacts 6A**

The control relay with highest switching reliability for control and signal circuits ranging from 10mA 5V.

**6A 250V~**  
 10mA 5V

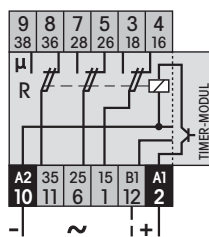

**Relay data:**  
 See page 4/5

**CT32R Universal-Timer**

7 functions, voltage controlled, time lapse display, blinking. Seismic approved.

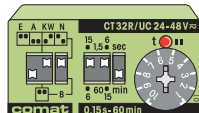

Function/Triggering

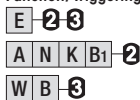

Timer Range

**0,15s-60min ★**  
 0,15-1,5s...  
 6-60min

Set Order-Nr.:

**CT32.31R/...V**  
**DC 24, 36V**

- Delivery includes:
- Relay C31D/R...
  - Module CT32R/...
  - Front cover FS-C
  - Socket C12B0
  - Retaining clip HF-32

Set Order-Nr.:

**CT32.32R/...V**  
**DC 24, 36V**

- Delivery includes:
- Relay C32D/R...
  - Module CT32R/...
  - Front cover FS-C
  - Socket C12B0
  - Retaining clip HF-32

**CT33R Universal-Timer**

12 functions, voltage controlled, time lapse display, blinking, high setting accuracy by dial graduation 1:5.

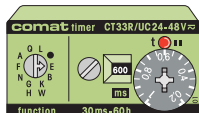

Function/Triggering

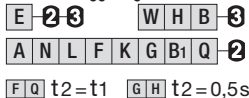

Timer Range

**30ms-60h ★**  
 30-150ms...  
 12-60h

Set Order-Nr.:

**CT33.31R/...V**  
**DC 24, 36V**

- Delivery includes:
- Relay C31D/R...
  - Module CT33R/...
  - Front cover FS-C
  - Socket C12B0
  - Retaining clip HF-32

Set Order-Nr.:

**CT33.32R/...V**  
**DC 24, 36V**

- Delivery includes:
- Relay C32D/R...
  - Module CT33R/...
  - Front cover FS-C
  - Socket C12B0
  - Retaining clip HF-32

**CT36R Universal-Taktgeber**

Pulse or pause start. t1/t2 separately settable. Time lapse display t1/t2.

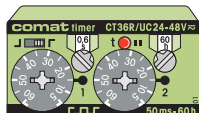

Function/Triggering



Timer Range

**2x50ms-60h ★**  
 2x50-600ms...  
 5-60h

Set Order-Nr.:

**CT36.31R/...V**  
**DC 24, 36V**

- Delivery includes:
- Relay C31D/R...
  - Module CT36R/...
  - Front cover FS-C
  - Socket C12B0
  - Retaining clip HF-32

Set Order-Nr.:

**CT36.32R/...V**  
**DC 24, 36V**

- Delivery includes:
- Relay C32D/R...
  - Module CT36R/...
  - Front cover FS-C
  - Socket C12B0
  - Retaining clip HF-32

**Dimensions [mm]**

See page 30.

**Technical approvals, conformities**

See table on page 53.

Notes



### 3. Monitoring Relays

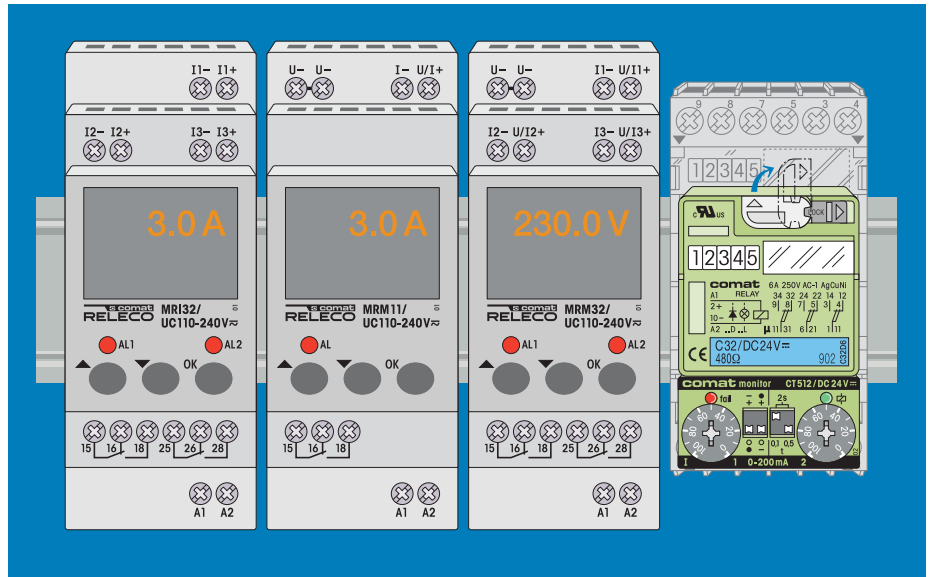

Application	Types	Monitoring	Monitoring range	Output contacts	Design
Voltage monitoring, AC / DC single phase	<b>MRU11R</b>		0 ... AC 480 V / DC 690 V		
Voltage monitoring, AC / DC three phase	<b>MRU32R</b>		0 ... AC 480 V / DC 690 V		
Current monitoring, AC / DC single phase	<b>MRI11R</b>		0 ... 5 A		
Current monitoring, AC / DC three phase	<b>MRI32R</b>		0 ... 5 A		
Multifunction monitoring, AC / DC single phase	<b>MRM11R</b>	   	U, I, P, f, cos φ		
Multifunction monitoring, AC / DC three phase	<b>MRM32R</b>	   	U, I, P, f, cos φ		
DC Voltage monitoring	<b>CT524.31R</b>		0 ... 30 V		
DC Voltage monitoring	<b>CT524.32R</b>		0 ... 30 V		
DC Current monitoring	<b>CT512.31R</b>		0 ... 200 mA		
DC Current monitoring	<b>CT512.32R</b>		0 ... 200 mA		
DC Current monitoring	<b>CT515.31R</b>		0 ... 2 A		
DC Current monitoring	<b>CT515.32R</b>		0 ... 2 A		
DC Current monitoring	<b>CT516.31R</b>		0 ... 6 A		
DC Current monitoring	<b>CT516.32R</b>		0 ... 6 A		
Isolation monitoring, DC networks	<b>ESU-D2</b>		1 ... 50 kΩ		50mm

# MRU11R

## Voltage monitoring relay AC/DC, single phase DIN Rail mounting according to DIN 43 880

### Type: MRU11R/...V

Voltage monitoring relay with over- and under voltage thresholds up to 690 V.  
Alarm delay setting. Alarm LED. Display for voltmeter function, alarm signal and interactive parameter setting.  
1 change-over alarm contact 6 A 250 V. Comfortable parameter setting.

### Monitoring function

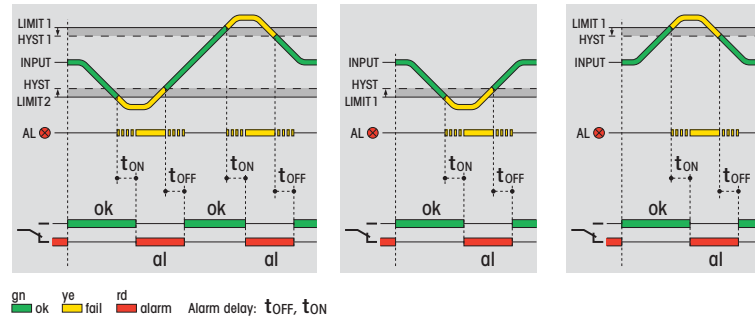

### Measuring circuit data

Over/under voltage setting ranges AC / DC	0 ... 480 V / 0 ... 690 V
Frequency	DC, AC 16 ... 100 Hz
Resolution	100 mV
Accuracy	2 % ± 1 digit
Input resistance	1 MΩ

### Time data

Alarm delay setting time	0.1 ... 999.9 s
Reset time setting range	0.1 ... 999.9 s
Voltage failure buffering	ca. 30 ms

### Contacts

Type / Material	1 CO / AgNi 0.15
Rated operational current	6 A
Max. inrush current	15 A
Max. switching voltage	250 V
Max. AC load AC-1 (Fig.1)	1250 VA
Max. DC load DC-1, 24 V / 220 V (Fig.2)	120 W / 25 W
Recommended min. contact load	10 mA / 10 V

### Power supply

	UC12-48V	UC110-240V
Nominal voltage AC/DC	12 ... 48 V	110 ... 240 V
Operating voltage range	10 ... 57 V	85 ... 250 V
AC frequency	16 ... 63 Hz	16 ... 63 Hz
Power consumption	2 W / 3 VA	2 W / 3 VA

### Insulation

Test voltage open - contact	1 kVrms 1 minute
Test voltage measuring input - contacts	4 kVrms 1 minute
Test voltage measuring input - power supply	4 kVrms 1 minute

### General specifications

Ambient temperature storage /operation	-40 ... +85 °C / -25 ... +60 °C
Mechanical life of contacts	30 x 10 <sup>6</sup> operations
Conductor cross section	Stranded wire 2.5 mm <sup>2</sup> , 2 x 1.5 mm <sup>2</sup>
Ingress protection rating	IP20
Max. screw torque	0.4 Nm
Housing material	Lexan EXL 9330
Weight	130 g

### Standard types

AC/DC 12-48 V, 15...60 Hz	MRU11R/UC12-48V
AC/DC 110-240 V, 15...60 Hz	MRU11R/UC110-240V

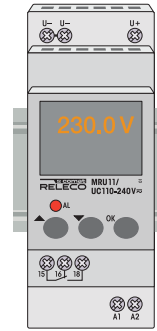

### Connection diagram

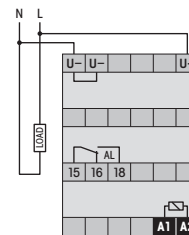

Fig. 1 AC voltage endurance

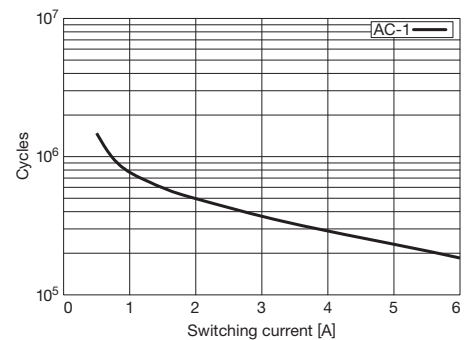
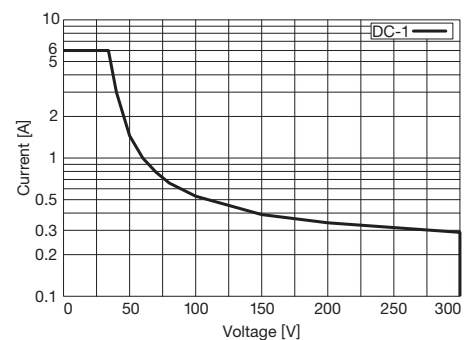
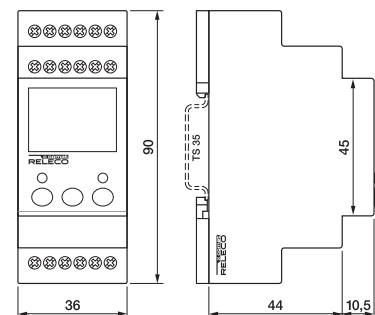

Fig. 2 DC load limit curve



### Dimensions [mm]



### Technical approvals, conformities

See table on page 53.

# MRU32R

## Voltage monitoring relay AC/DC, three phase DIN Rail mounting according to DIN 43 880

### Type: MRU32R/...V

Voltage monitoring relay with over- and under voltage thresholds up to 690 V.  
Alarm delay setting. Alarm LED. Display for voltmeter function, alarm signal and interactive parameter setting.  
2 change-over alarm contacts 6 A 250 V. Comfortable parameter setting.

### Monitoring function

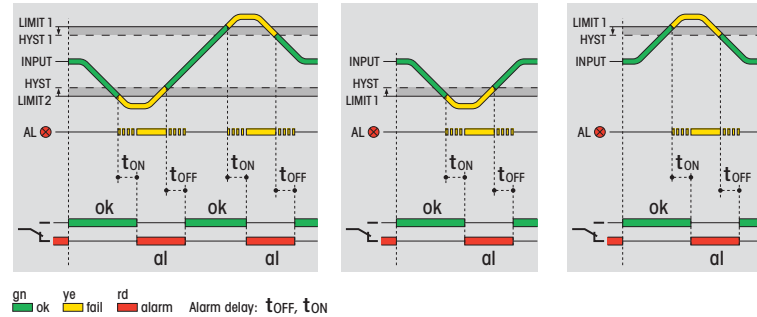

### Measuring circuit data

Over/under voltage setting ranges AC / DC	0 ... 480 V / 0 ... 690 V
Frequency	DC, AC 16 ... 100 Hz
Resolution	100 mV
Accuracy	2 % ± 1 digit
Input resistance	1 MΩ

### Time data

Alarm delay setting time	0.1 ... 999.9 s
Reset time setting range	0.1 ... 999.9 s
Voltage failure buffering	ca. 30 ms

### Contacts

Type / Material	2 CO / AgNi 0.15	
Rated operational current	6 A	
Max. inrush current	15 A	
Max. switching voltage	250 V	
Max. AC load AC-1 (Fig.1)	1250 VA	
Max. DC load DC-1, 24 V / 220 V (Fig.2)	120 W / 25 W	
Recommended min. contact load	10 mA / 10 V	

### Power supply

	UC 12-48V	UC 110-240V
Nominal voltage AC/DC	12 ... 48 V	110 ... 240 V
Operating voltage range	10 ... 57 V	85 ... 250 V
AC frequency	16 ... 63 Hz	16 ... 63 Hz
Power consumption	2 W / 3 VA	2 W / 3 VA

### Insulation

Test voltage open - contact	1 kVrms 1 minute
Test voltage between poles	2.5 kVrms 1 minute
Test voltage measuring input - contacts	4 kVrms 1 minute
Test voltage measuring input - power supply	4 kVrms 1 minute

### General specifications

Ambient temperature storage /operation	-40 ... +85 °C / -25 ... +60 °C
Mechanical life of contacts	30 x 10 <sup>6</sup> operations
Conductor cross section	Stranded wire 2.5 mm <sup>2</sup> , 2 x 1.5 mm <sup>2</sup>
Ingress protection rating	IP20
Max. screw torque	0.4 Nm
Housing material	Lexan EXL 9330
Weight	130 g

### Standard types

AC/DC 12-48 V, 15...60 Hz  
AC/DC 110-240 V, 15...60 Hz

MRU32R/UC12-48VR  
MRU32/UC110-240V

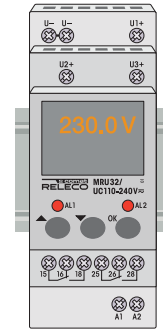

### Connection diagram

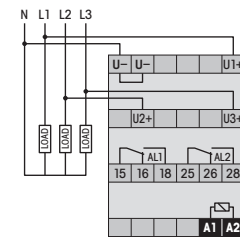

Fig. 1 AC voltage endurance

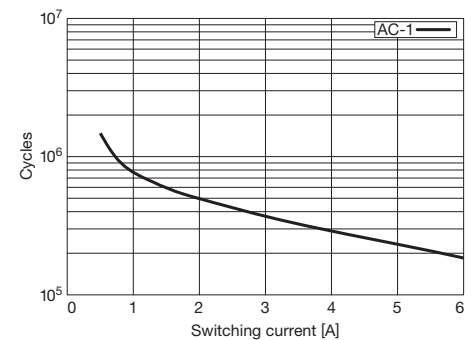
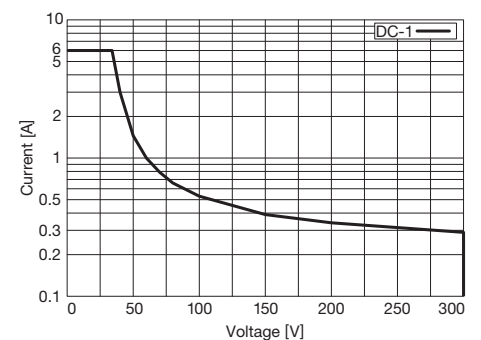
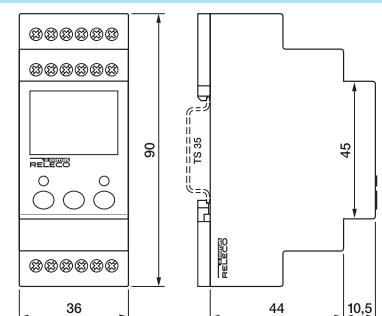

Fig. 2 DC load limit curve



### Dimensions [mm]



### Technical approvals, conformities

See table on page 53.

# MRI11R

## Current monitoring relay AC/DC, single phase DIN Rail mounting according to DIN 43 880



### Type: MRI11R/...V

Current monitoring relay with over- and under voltage thresholds up to 5 A. Alarm delay setting. Alarm LED. Display for voltmeter function, alarm signal and interactive parameter setting.

1 change-over alarm contact 6 A 250 V. Comfortable parameter setting.

### Monitoring function

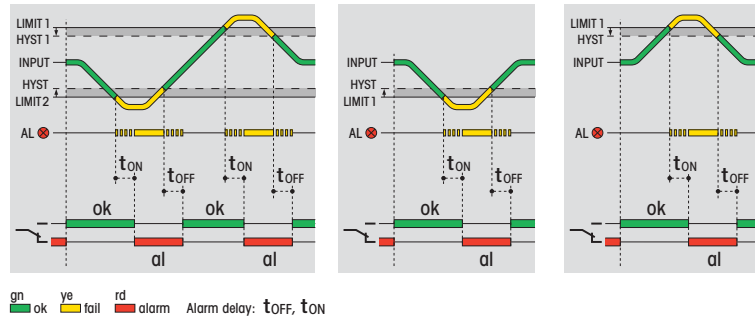

### Measuring circuit data

Over-/under current setting ranges AC / DC	0 ... 5 A
Frequency	DC, AC 16 ... 100 Hz
Resolution	100 mA
Accuracy	2 % ± 1 digit
Input resistance	5 mΩ

### Time data

Alarm delay setting time	0.1 ... 999.9 s
Reset time setting range	0.1 ... 999.9 s
Voltage failure buffering	ca. 30 ms

### Contacts

Type / Material	1 CO / AgNi 0.15	
Rated operational current	6 A	
Max. inrush current	15 A	
Max. switching voltage	250 V	
Max. AC load AC-1 (Fig.1)	1250 VA	
Max. DC load DC-1, 24 V / 220 V (Fig.2)	120 W / 25 W	
Recommended min. contact load	10 mA / 10 V	

### Power supply

	UC12-48V	UC110-240V
Nominal voltage AC/DC	12 ... 48 V	110 ... 240 V
Operating voltage range	10 ... 57 V	85 ... 250 V
AC frequency	16 ... 63 Hz	16 ... 63 Hz
Power consumption	2 W / 3 VA	2 W / 3 VA

### Insulation

Test voltage open - contact	1 kVrms 1 minute
Test voltage measuring input - contacts	4 kVrms 1 minute
Test voltage measuring input - power supply	4 kVrms 1 minute

### General specifications

Ambient temperature storage /operation	-40 ... +85 °C / -25 ... +60 °C
Mechanical life of contacts	30 x 10 <sup>6</sup> operations
Conductor cross section	Stranded wire 2.5 mm <sup>2</sup> , 2 x 1.5 mm <sup>2</sup>
Ingress protection rating	IP20
Max. screw torque	0.4 Nm
Housing material	Lexan EXL 9330
Weight	130 g

### Standard types

- UC 12-48 V (AC/DC), 15...60 Hz
- UC 110-240 V (AC/DC), 15...60 Hz

MRI11R/UC12-48V  
MRI11R/UC110-240V

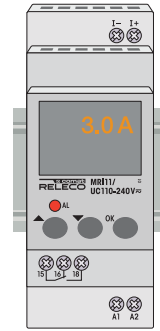

### Connection diagram

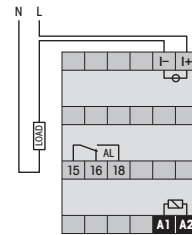

Fig. 1 AC voltage endurance

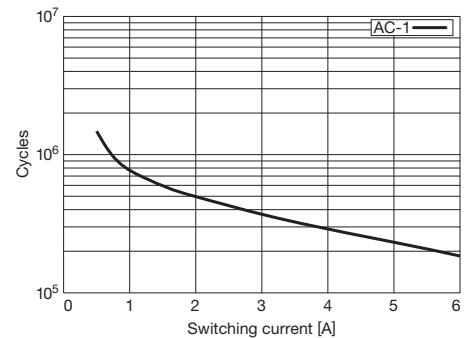
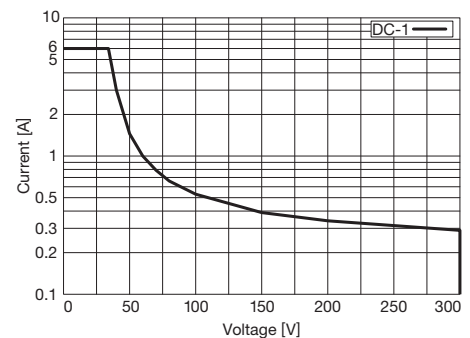
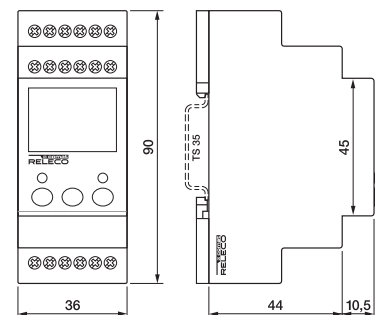

Fig. 2 DC load limit curve



### Dimensions [mm]



### Technical approvals, conformities

See table on page 53.

# MRI32R

## Current monitoring relay AC/DC, three phase DIN Rail mounting according to DIN 43 880



### Type: MRI32R/...V

Current monitoring relay with over- and under current thresholds up to 5 A.  
Alarm delay setting. Alarm LED. Display for voltmeter function, alarm signal  
and interactive parameter setting.  
2 change-over alarm contacts 6 A 250 V. Comfortable parameter setting.

### Monitoring function

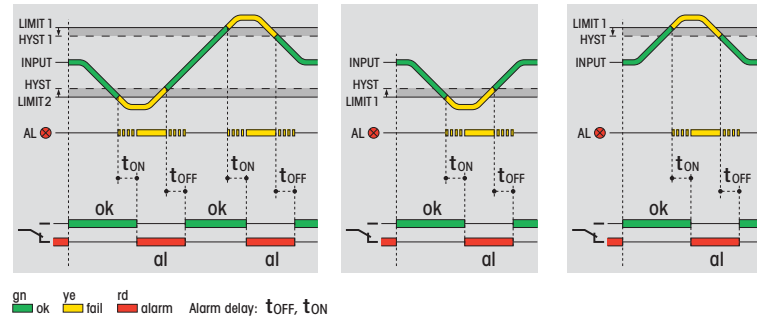

### Measuring circuit data

Over/under current setting ranges AC / DC	0 ... 5 A
Frequency	DC, AC 16 ... 100 Hz
Resolution	100 mA
Accuracy	2 % ± 1 digit
Input resistance	5 mΩ

### Time data

Alarm delay setting time	0.1 ... 999.9 s
Reset time setting range	0.1 ... 999.9 s
Voltage failure buffering	ca. 30 ms

### Contacts

Type / Material	2 CO / AgNi 0.15	
Rated operational current	6 A	
Max. inrush current	15 A	
Max. switching voltage	250 V	
Max. AC load AC-1 (Fig.1)	1250 VA	
Max. DC load DC-1, 24 V / 220 V (Fig.2)	120 W / 25 W	
Recommended min. contact load	10 mA / 10 V	

### Power supply

	UC12-48V	UC110-240V
Nominal voltage AC/DC	12 ... 48 V	110 ... 240 V
Operating voltage range	10 ... 57 V	85 ... 250 V
AC frequency	16 ... 63 Hz	16 ... 63 Hz
Power consumption	2 W / 3 VA	2 W / 3 VA

### Insulation

Test voltage open - contact	1 kVrms 1 minute
Test voltage between poles	2.5 kVrms 1 minute
Test voltage measuring input - contacts	4 kVrms 1 minute
Test voltage measuring input - power supply	4 kVrms 1 minute

### General specifications

Ambient temperature storage /operation	-40 ... +85 °C / -25 ... +60 °C
Mechanical life of contacts	30 x 10 <sup>6</sup> operations
Conductor cross section	Stranded wire 2.5 mm <sup>2</sup> , 2 x 1.5 mm <sup>2</sup>
Ingress protection rating	IP20
Max. screw torque	0.4 Nm
Housing material	Lexan EXL 9330
Weight	130 g

### Standard types

**UC 12-48 V (AC/DC), 15...60 Hz**  
**UC 110-240 V (AC/DC), 15...60 Hz**

**MRI32R/UC12-48V**  
**MRI32R/UC110-240V**

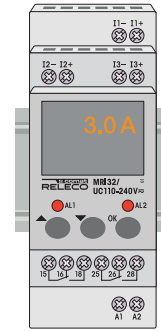

### Connection diagram

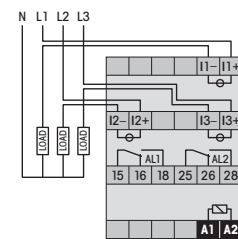

Fig. 1 AC voltage endurance

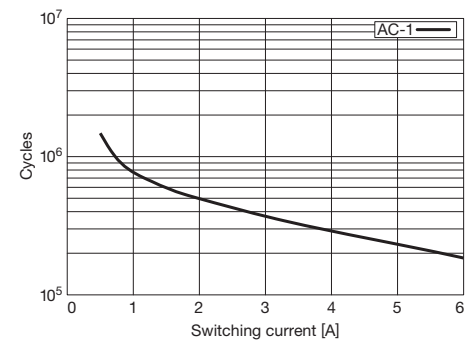
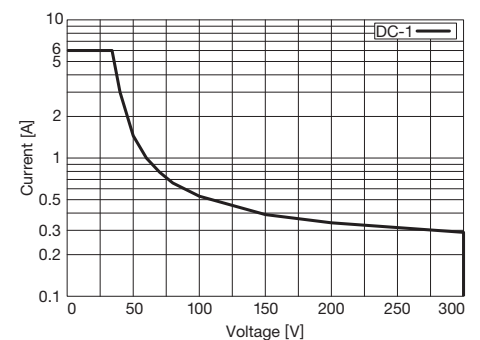
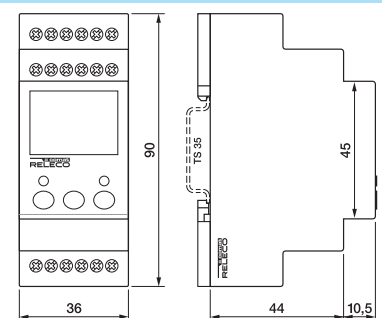

Fig. 2 DC load limit curve



### Dimensions [mm]



### Technical approvals, conformities

See table on page 53.

# MRM11R

## Multifunction monitoring relay AC/DC, single phase DIN Rail mounting according to DIN 43 880

### Type: MRM11R/...V

Multifunctional monitoring relay for simultaneous measurement of current and voltage and monitoring of U, I, P, cosφ and f. Alarm delay setting. Alarm LED. Display for multimeter function, alarm signal and interactive parameter setting.

1 change-over alarm contact 6 A 250 V. Comfortable parameter setting.

### Monitoring function

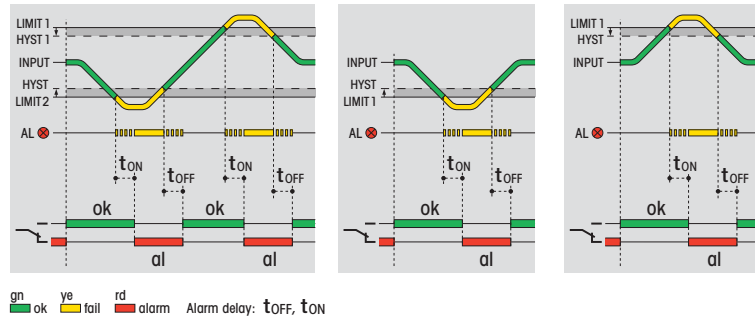

### Measuring circuit data

Voltage setting ranges AC / DC	0 ... 480 V / 0 ... 690 V
Current setting ranges AC / DC	0 ... 5 A
Frequency	DC, AC 16 ... 100 Hz
Resolution U / I	100 mV / 100 mA
Accuracy	2 % ± 1 digit
Input resistance U / I	1 MΩ / 5 mΩ

### Time data

Alarm delay setting time	0.1 ... 999.9 s
Reset time setting range	0.1 ... 999.9 s
Voltage failure buffering	ca. 30 ms

### Contacts

Type / Material	1 CO / AgNi 0.15
Rated operational current	6 A
Max. inrush current	15 A
Max. switching voltage	250 V
Max. AC load AC-1 (Fig.1)	1250 VA
Max. DC load DC-1, 24 V / 220 V (Fig.2)	120 W / 25 W
Recommended min. contact load	10 mA / 10 V

### Power supply

	UC12-48V	UC110-240V
Nominal voltage AC/DC	12 ... 48 V	110 ... 240 V
Operating voltage range	10 ... 57 V	85 ... 250 V
AC frequency	16 ... 63 Hz	16 ... 63 Hz
Power consumption	2 W / 3 VA	2 W / 3 VA

### Insulation

Test voltage open - contact	1 kVrms 1 minute
Test voltage measuring input - contacts	4 kVrms 1 minute
Test voltage measuring input - power supply	4 kVrms 1 minute

### General specifications

Ambient temperature storage /operation	-40 ... +85 °C / -25 ... +60 °C
Mechanical life of contacts	30 x 10 <sup>6</sup> operations
Conductor cross section	Stranded wire 2.5 mm <sup>2</sup> , 2 x 1.5 mm <sup>2</sup>
Ingress protection rating	IP20
Max. screw torque	0.4 Nm
Housing material	Lexan EXL 9330
Weight	130 g

### Standard types

UC 12-48 V (AC/DC), 15...60 Hz  
UC 110-240 V (AC/DC), 15...60 Hz

MRM11R/UC12-48V  
MRM11R/UC110-240V

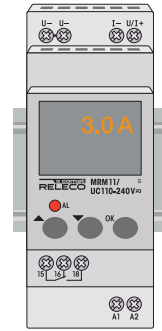

### Connection diagram

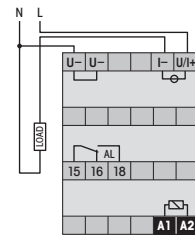

Fig. 1 AC voltage endurance

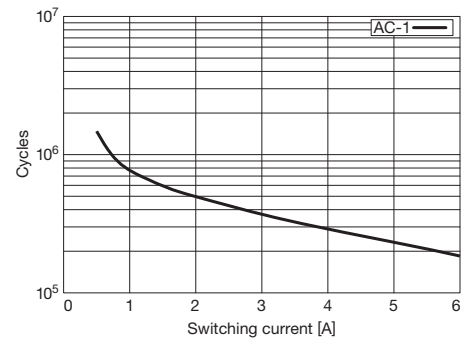
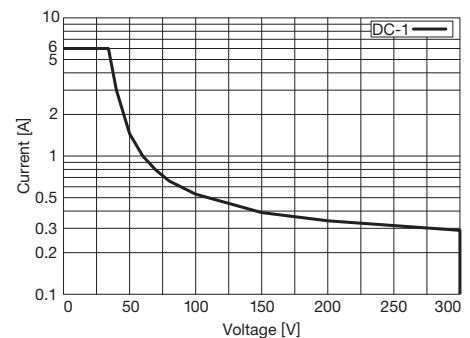
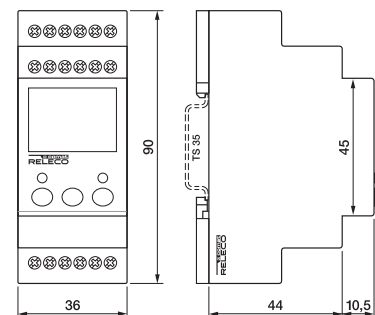

Fig. 2 DC load limit curve



### Dimensions [mm]



### Technical approvals, conformities

See table on page 53.



# MRM32R

## Multifunction monitoring relay AC/DC, three phase DIN Rail mounting according to DIN 43 880

### Type: MRM32R/...V

Multifunctional monitoring relay for simultaneous measurement of current and voltage and monitoring of U, I, P, cosφ and f and Δφ. Alarm delay setting. Alarm LED. Display for multimeter function, alarm signal and interactive parameter setting.

2 change-over alarm contacts 6 A 250 V. Comfortable parameter setting.

### Monitoring function

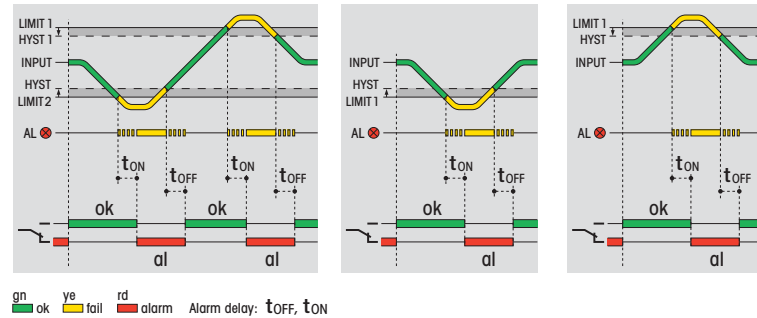

### Measuring circuit data

Voltage setting ranges AC / DC	0 ... 480 V / 0 ... 690 V
Current setting ranges AC / DC	0 ... 5 A
Frequency	DC, AC 16 ... 100 Hz
Resolution U / I	100 mV / 100 mA
Accuracy	2 % ±1 digit
Input resistance U / I	1 MΩ / 5 mΩ

### Time data

Alarm delay setting time	0.1 ... 999.9 s
Reset time setting range	0.1 ... 999.9 s
Voltage failure buffering	ca. 30 ms

### Contacts

Type / Material	2 CO / AgNi 0.15
Rated operational current	6 A
Max. inrush current	15 A
Max. switching voltage	250 V
Max. AC load AC-1 (Fig.1)	1250 VA
Max. DC load DC-1, 24 V / 220 V (Fig.2)	120 W / 25 W
Recommended min. contact load	10 mA / 10 V

### Power supply

	UC 12-48V	UC 110-240V
Nominal voltage AC/DC	12 ... 48 V	110 ... 240 V
Operating voltage range	10 ... 57 V	85 ... 250 V
AC frequency	16 ... 63 Hz	16 ... 63 Hz
Power consumption	2 W / 3 VA	2 W / 3 VA

### Insulation

Test voltage open - contact	1 kVrms 1 minute
Test voltage between poles	2.5 kVrms 1 minute
Test voltage measuring input - contacts	4 kVrms 1 minute
Test voltage measuring input - power supply	4 kVrms 1 minute

### General specifications

Ambient temperature storage /operation	-40 ... +85 °C / -25 ... +60 °C
Mechanical life of contacts	30 x 10 <sup>6</sup> operations
Conductor cross section	Stranded wire 2.5 mm <sup>2</sup> , 2 x 1.5 mm <sup>2</sup>
Ingress protection rating	IP20
Max. screw torque	0.4 Nm
Housing material	Lexan EXL 9330
Weight	130 g

### Standard types

UC 12-48 V (AC/DC), 15...60 Hz

UC 110-240 V (AC/DC), 15...60 Hz

MRM32R/UC12-48V

MRM32R/UC110-240V

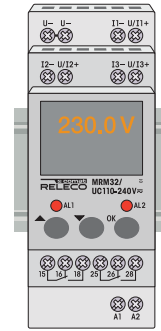

### Connection diagram

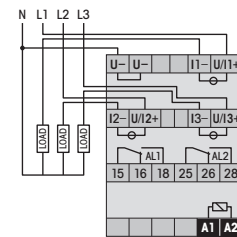

Fig. 1 AC voltage endurance

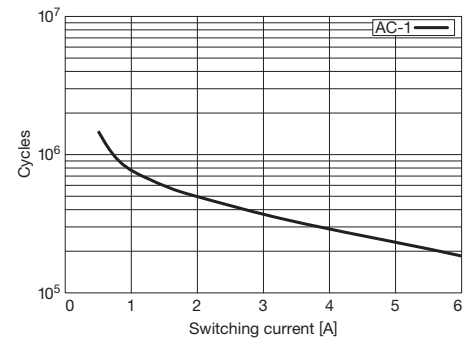
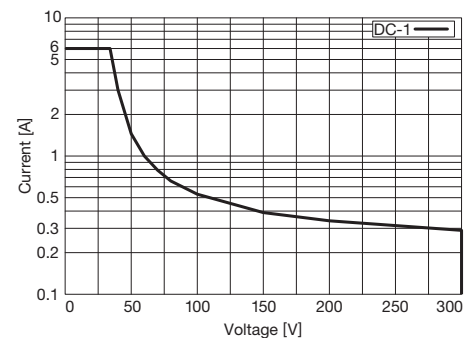
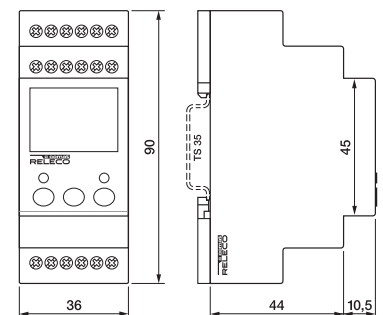

Fig. 2 DC load limit curve



### Dimensions [mm]



### Technical approvals, conformities

See table on page 53.

# CT512R, CT515R, CT516R

## Plug-in current monitoring module; 0.2 A, 2 A, 6 A. DC 24 V operation

**Type: CT512R, CT515R, CT516R /... V**

Plug-in current monitoring modules for sockets with module slot in combination with plug-in relays. DC 24 V operation. LED alarm state indicators for OK and fail. Separate adjustment of upper and lower level.

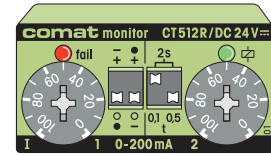

### Monitoring functions

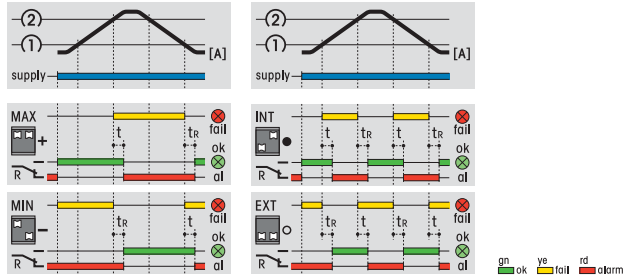

Over / under voltage      internal / external range

### Measuring circuit data

Type	CT512R	CT515R	CT516R
Measuring and setting ranges (rotary knobs)	0 ... 200 mA	0 ... 2 A	0 ... 6 A
Max. current 100% duty cycle	300 mA	3 A	7 A
Voltage drop on internal shunt res. @ I <sub>max</sub>	300 mV	200 mV	100 mV
Temperature drift -25 ... 60 °C	≤ 3 %	≤ 3 %	≤ 3 %

### Time data

Alarm delay time settings	100 ms, 500 ms, 2 s
Reset time	100 ms

### Power supply

	DC 24 V	DC 36 V
Nominal voltage	18 ... 30 V	18 ... 45 V
Operation voltage range	3 ... 7 mA	5 mA
Supply current	- 30 V	- 51 V
Polarity reversal protection		

### General specifications

Ambient temperature storage/operation	-40 ... +85 °C / -40 ... +70 °C
Ingress protection rating	IP 40 when plugged in
Housing material	Lexan
Weight	25 g

### Standard types

CT512R	CT512R/DC24V	CT512R/DC36V
CT515R	CT515R/DC24V	CT515R/DC36V
CT516R	CT516R/DC24V	CT516R/DC36V

**Remark:** This module is part of several ready for connection units consisting of socket, relay and module.  
A wide variety of suitable relays is available.

### Connection diagram

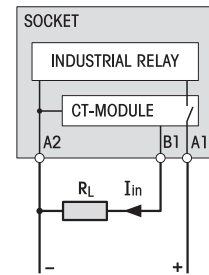

### Dimensions [mm]

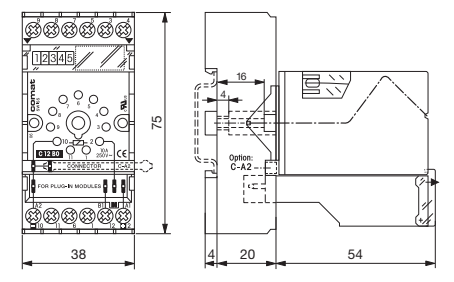

### Technical approvals, conformities

See table on page 53.

# CT524R, plug-in DC voltage monitoring module

## Plug-in DC voltage monitoring module

### Type: CT524R/...V

Plug-in DC voltage monitoring module for sockets with module slot in combination with 11p plug-in relays. DC 24 V operation. LED alarm state indicators for OK and fail. Separate adjustment of upper and lower level.

### Monitoring functions

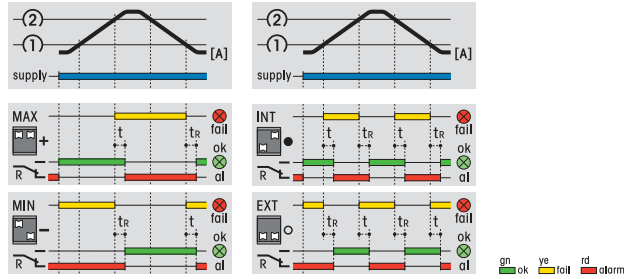

Over / under voltage      internal / external range

### Measuring circuit data

Type	<b>CT524R</b>
Measuring and setting ranges (rotary knobs)	0 ... 30 V
Over voltage (10 ms)	± 150 V
Input resistance	106 kΩ
Temperature drift -25 ... 60 °C	≤ 2 %

### Time data

Alarm delay time settings	100 ms, 500 ms, 2 s
Reset time	100 ms

### Power supply

Nominal voltage	<b>DC 24 V</b>
Operation voltage range	18 ... 30 V
Supply current	8 ... 13 mA
Polarity reversal protection (1 minute)	- 30 V

### General specifications

Ambient temperature storage/operation	-40 ... +85 °C / -40 ... +70 °C
Ingress protection rating	IP 40 when plugged in
Housing material	Lexan
Weight	25 g

### Standard types

<b>CT524R</b>	<b>CT524R/DC24V</b>
---------------	---------------------

**Remark:** This module is part of several ready for connection units consisting of socket, relay and module.

A wide variety of suitable relays is available.

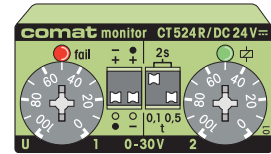

### Connection diagram

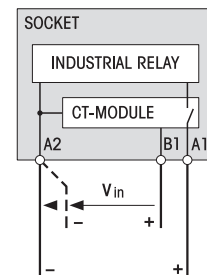

### Dimensions [mm]

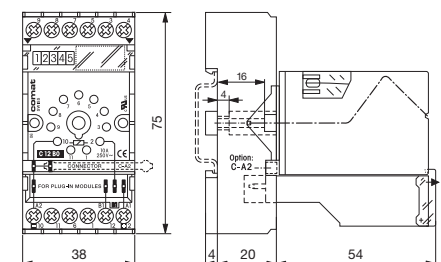

### Technical approvals, conformities

See table on page 53.

DC Voltage Monitoring-Set  
DC Current Monitoring-Set

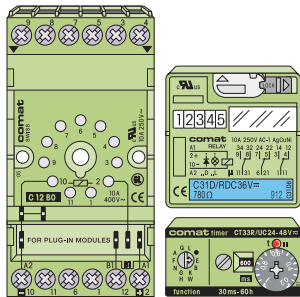

Set-Delivery includes:

- Relay
- Module
- Front cover
- Socket
- Retaining clip

Relay data's see:  
Section Industrial Relays



Power Relay

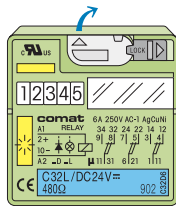
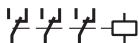

C31L

Universal Power Relay 10A with 3 power change-over-contacts this is the robust relay for AC and DC circuits ranging from 50mA 10V.

10A 250V~  
50mA 10V

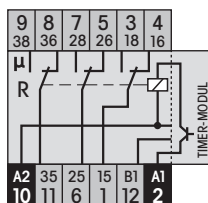

Control Relay

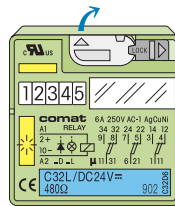

C32L

Relay with 3 twin contacts 6A The control relay with highest switching reliability for control and signal circuits ranging from 10mA 5V.

6A 250V~  
10mA 5V

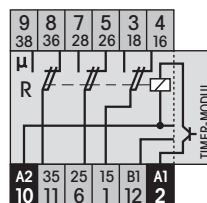

Monitoring Module

4 functions can be selected: Overvoltage / undervoltage monitoring with adjustable hysteresis or 2 range monitors (INT or EXT). Adjustable alarm delay. LED display for errors and ok. Contact inspection window at the top. Manual safety operation.

Module see page 40/41

CT524

DC Voltage Monitoring

Range: 0-30V  
Umax: 40V

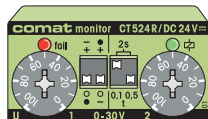

Triggering

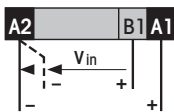

Input resistance  
B1 → A2: 100kΩ

Set Order-Nr.:

CT524.31R/24V

- Delivery includes:
- Relay C31L/DC24V
  - Module CT524/DC24V
  - Front cover FS-C
  - Socket C12B0
  - Retaining clip HF-32

Set Order-Nr.:

CT524.32R/24V

- Delivery includes:
- Relay C32L/DC24V
  - Module CT524/DC24V
  - Front cover FS-C
  - Socket C12B0
  - Retaining clip HF-32

CT512

DC Current Monitoring

Range: 0-200mA  
Imax: 300mA

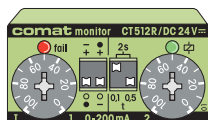

Triggering

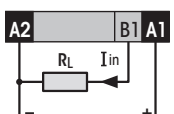

Voltage drop  
A1 → B1 ≤ 300mV

Set Order-Nr.:

CT512.31R/...V  
DC 24, 36V

- Delivery includes:
- Relay C31L/DC24V
  - Module CT512/DC24V
  - Front cover FS-C
  - Socket C12B0
  - Retaining clip HF-32

Set Order-Nr.:

CT512.32R/...V  
DC 24, 36V

- Delivery includes:
- Relay C32L/DC24V
  - Module CT512/DC24V
  - Front cover FS-C
  - Socket C12B0
  - Retaining clip HF-32

CT515

DC Current Monitoring

Range: 0-2A  
Imax: 3A



Triggering

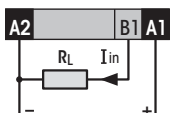

Voltage drop  
A1 → B1 ≤ 200mV

Set Order-Nr.:

CT515.31R/...V  
DC 24, 36V

- Delivery includes:
- Relay C31L/DC24V
  - Module CT515/DC24V
  - Front cover FS-C
  - Socket C12B0
  - Retaining clip HF-32

Set Order-Nr.:

CT515.32R/...V  
DC 24, 36V

- Delivery includes:
- Relay C32L/DC24V
  - Module CT515/DC24V
  - Front cover FS-C
  - Socket C12B0
  - Retaining clip HF-32

CT516

DC Current Monitoring

Range: 0-6A  
Imax: 7A

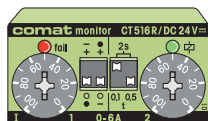

Triggering

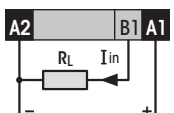

Voltage drop  
A1 → B1 ≤ 100mV

Set Order-Nr.:

CT516.31R/...V  
DC 24, 36V

- Delivery includes:
- Relay C31L/DC24V
  - Module CT516/DC24V
  - Front cover FS-C
  - Socket C12B0
  - Retaining clip HF-32

Set Order-Nr.:

CT516.32R/...V  
DC 24, 36V

- Delivery includes:
- Relay C32L/DC24V
  - Module CT516/DC24V
  - Front cover FS-C
  - Socket C12B0
  - Retaining clip HF-32

Dimensions [mm]

See page 40.

Technical approvals, conformities

See table on page 53.

## ESU-D2R

### Insulation monitoring relay for unearthed DC-networks DIN Rail mounting

#### Type: ESU-D2R/UC24V

Earth insulation resistance monitoring relay

Pre alarm 1 CO and main alarm 1 NO + 1 CO contact outputs 5 A / 250 V

UC 24 ... 48 V, operating voltages, monitoring of DC 12 ... 48 V power supply networks.

Monitoring of earth interruption on the device.

The device measures single or combined resistances occurring against + or - pole of the DC network. Adjustable alarm delay. Proved reliability in rolling stock applications.

#### Monitoring function

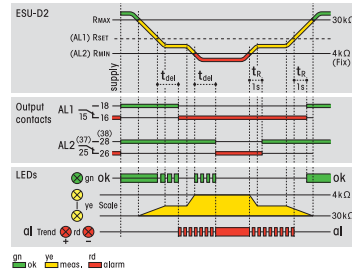

The ESU-D2 monitors the isolation resistance in non-grounded DC-networks (24 – 48 V).

Two alarm steps (prealarm AL1 and main alarm AL2) are indicated via separate output contacts.

Displays: bargraph-display of the measured earthing resistance (green = ok). Two red LEDs show the ground tendency towards plus (+) or minus (-).

Output terminals 5 V for the external display of the earthing resistance (0,1 V/k $\Omega$ ).

Test functions: Periodic automatic check, also with key "Test".

Environmental failures: monitoring of AC-short circuit, over-voltage, ground interruption.

#### Measuring circuit data

Measuring / setting range for pre alarm	1 ... 50 k $\Omega$ / 4 ... 30 k $\Omega$
Constant value for main alarm	4 k $\Omega$
Tolerance	$\leq 10\%$
Overvoltage alarm level of DC network	60 V
Input current + $\rightarrow$ -	$\leq 5$ mA
Sampling current pulses +/- $\rightarrow$ earth	0.2 mA
Overvoltage safety from earth to +/- poles	AC 250 V
Max. capacity +/- $\rightarrow$ earth	1.5 $\mu$ F <sup>1)</sup>

<sup>1)</sup> Types for capacitances until 60  $\mu$ F on request

#### Time data

Alarm delay time adjustment range	0.1 ... 10 s
Fault detection time	600 ms
Auto reset time, fail to OK	1 s

#### Contacts

Type / Material	2 CO, 1 NO micro disconnection / AgNi
Rated operational current / min. contact load	5 A / 1 mA 12 V
Max. switching voltage (Fig. 1)	250 V

#### Power supply

Nominal voltage	<b>UC 24-48 V</b>
Operation voltage range	16.8 ... 60 V
Power consumption	2 W
Voltage failure buffering	$\geq 50$ ms

#### Insulation

Test voltage contacts to other circuits	2 kVrms 1 minute
---	------------------

#### General specifications

Ambient temperature storage /operation	-40 ... +85 $^{\circ}$ C / -40 ... +70 $^{\circ}$ C
Ingress protection rating	Housing: IP 40, terminals: IP 20
Max. screw torque	0.5 Nm
Weight	250 g

#### Standard types

UC24-48 (AC/DC)

ESU-D2R/UC24-48V

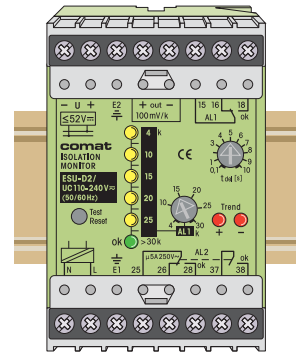

#### Connection diagram

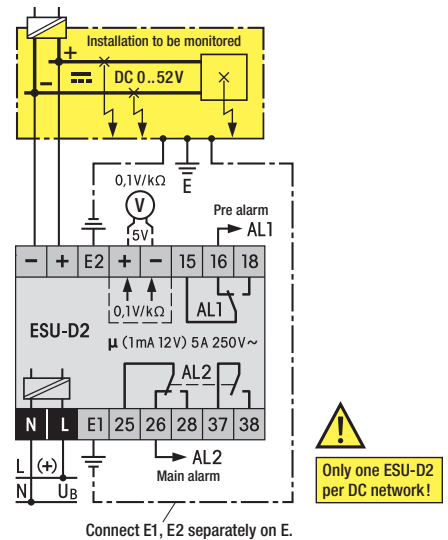
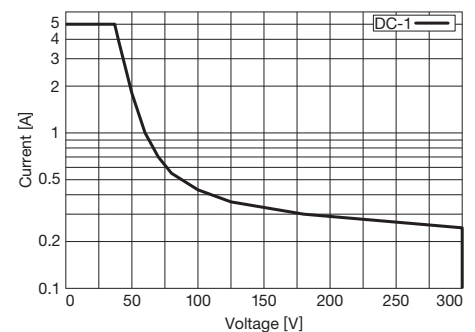
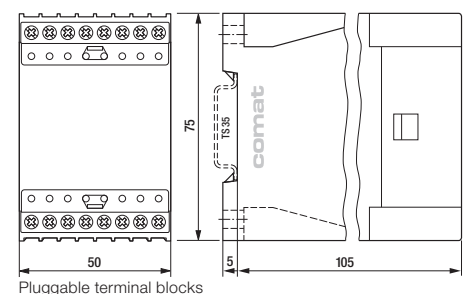

Fig. 2 DC load limit curve



#### Dimensions [mm]







#### Technical approvals, conformities

See table on page 53.

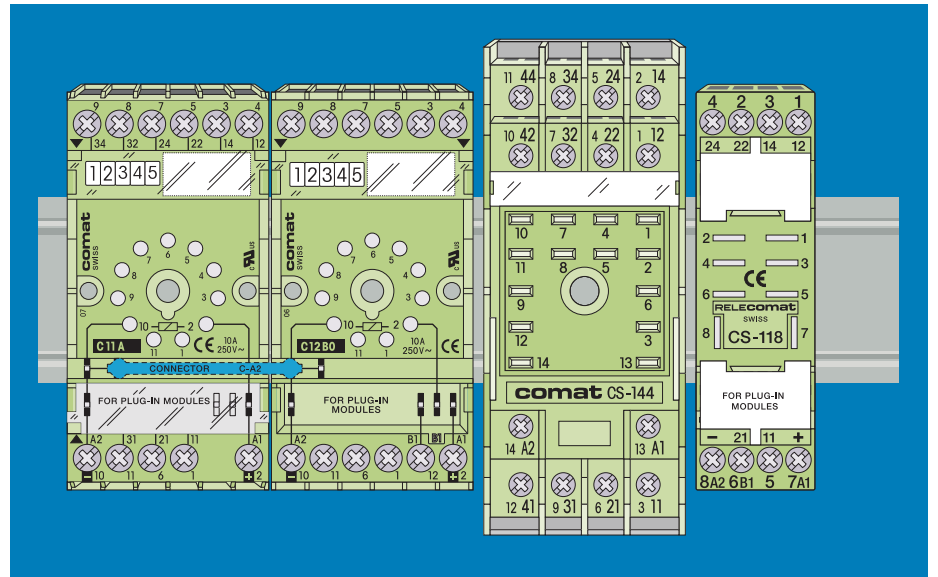

## 4. Sockets



Application	Types	Rated load	Pins
Socket for 11 pin relays and plug-in modules	<b>C11A</b>	10A, 250V	
Socket for 11 pin relays and plug-in modules	<b>C12B0</b>	10A, 250V	
Socket for 14 pin relays	<b>CS-144</b>	10A, 250V	
Socket for miniature relays	<b>CS-118</b>	10A, 250V	

# C11A

## Socket for 11 pin plug-in relays C31D/R, C32D/R, R3-N3x and plug-in modules



### Type: C11A

3-pole, 1 level

Module slot for over voltage suppressing and LED indicator modules, coil bridge bus bar to connect in A2

**Rated current** 10 A

### Specifications

Rated load	10 A
Insulation	Test voltage $V_{rms}$ / 1 min
- All terminals/DIN rail	2.5 kV
- Terminal/terminal	2.5 kV
Cross-section of connecting wire	
- Multi-wire	1 x 4 mm <sup>2</sup> , 2 x 2.5 mm <sup>2</sup>
Max. screw torque	0.7 Nm
Screw dimensions	M3, Pozi, slot
Labelling space	detachable
Connection label	1...11; DIN/EN
Mounting	DIN rail TS35 or panel mounting
Ambient temperature operation / storage	-40 (no ice) ... +70 °C / -40 ... +85 °C
Weight	56 g

**Associated plug-in 11-pin relays** C31D/R, C32D/R and R3-N3x

**Type** C11A

### Accessories

Retaining springs, steel	<b>HF-32</b> (Relays C31, C32) <b>HF-33</b> (Timecube + Relays C31, C32) <b>S3-C</b> (Relays R3-N3x)
Coil bridge bus bar	<b>C-A2</b>
Marking strip cardboard white 8 x 16	<b>L-16/5</b> (under transp. plastic cover)
Illuminated display	<b>RL1/...</b>
Suppressing unit	<b>RC1/...</b> <b>RCL1/...</b> <b>RD1/...</b>

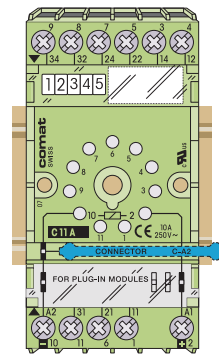

### Connection diagram

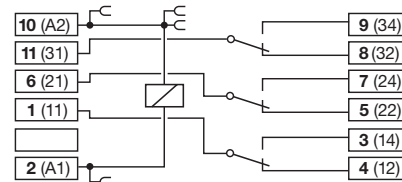

### Dimensions [mm]

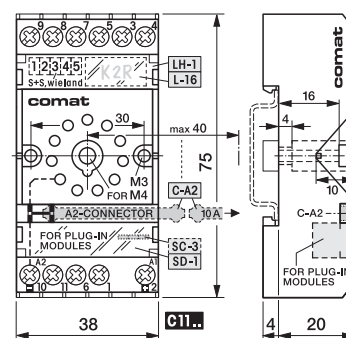

### Technical approvals, conformities

See table on page 53.



## C12B0

### Socket for 11 pin plug-in relays C31D/R, C32D/R, R3-N3x and plug-in control modules

#### Type: C12B0

3-pole, 1 level  
 Module slot for timer- and monitoring modules, over voltage suppressing and LED indicator modules  
 coil bridge bus bar to connect in A2

**Rated current** **10 A**

#### Specifications

Rated load	10 A
Insulation	Test voltage $V_{rms}$ / 1 min
– All terminals/DIN rail	2.5 kV
– Terminal/terminal	2.5 kV
Cross-section of connecting wire	
– Multi-wire	1 x 4 mm <sup>2</sup> , 2 x 2.5 mm <sup>2</sup>
Max. screw torque	0.7 Nm
Screw dimensions	M3, Pozi, slot
Labelling space	detachable
Connection label	1...12; DIN/EN
Mounting	DIN rail TS35 or panel mounting
Ambient temperature operation / storage	-40 (no ice) ... +70 °C / -40 ... +85 °C
Weight	61 g

**Associated plug-in 11-pin relays** **C31D/R, C32D/R and R3-N3x**

**Type** **C12B0**

#### Accessories

Retaining springs, steel	<b>HF-32</b> (Relays C31, C32) <b>HF-33</b> (Timecube + Relays C31, C32) <b>S3-C</b> (Relays R3-N3x)
Coil bridge bus bar	<b>C-A2</b>
Marking strip cardboard white 8 x 16	<b>L-16/5</b> (under transp. plastic cover)
Illuminated display	<b>RL1/...</b>
Suppressing unit	<b>RC1/...</b> <b>RCL1/...</b> <b>RD1/...</b>

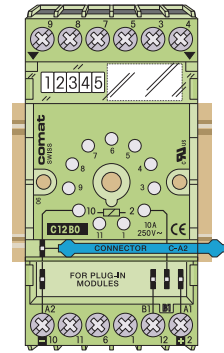

#### Connection diagram

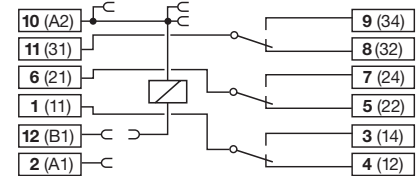

#### Dimensions [mm]

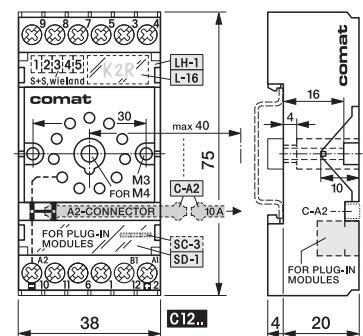

#### Technical approvals, conformities

See table on page 53.

# CS-144

## Socket for 14-pin plug-in relays R4-Ax



### Type: CS-144

4-pole, 2 connection level  
Integrated retaining clip and labelling space

**Rated current** **10 A**

### Specifications

Rated load	10 A / 250 V
Insulation	Test voltage $V_{rms}$ / 1 min
– All terminals/DIN rail	2.5 kV
– Terminal/terminal	2.5 kV
Cross-section of connecting wire	
– Single-wire	4 mm <sup>2</sup> or 2 x 2.5 mm <sup>2</sup>
– Multi-wire	22 - 14 AWG
Max. screw torque	1 Nm
Screw dimensions	M3.5, Pozi, slot
Integrated retaining clip/plastic	for relay series C4
Labelling space	detachable
Connection label	1...14; DIN/EN
Mounting	DIN rail TS35 or panel mounting
Ambient temperature operation / storage	-40 (no ice) ... +70 °C / -40 ... +80 °C
Weight	80 g

**Associated, plug-in 14-pin relays** **R4-A4x**

**Type** **CS-144**

### Accessories

Retaining spring, steel	<b>S4-C</b>
Retaining clip, plastic	<b>S3-CMG</b>

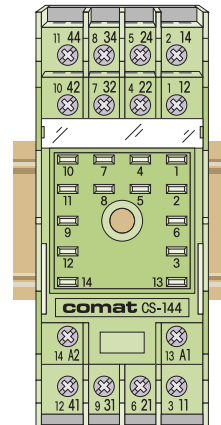

### Connection diagram

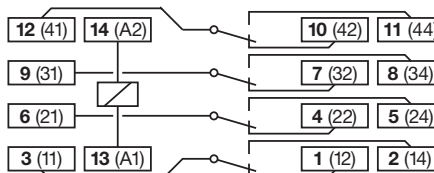

### Dimensions [mm]

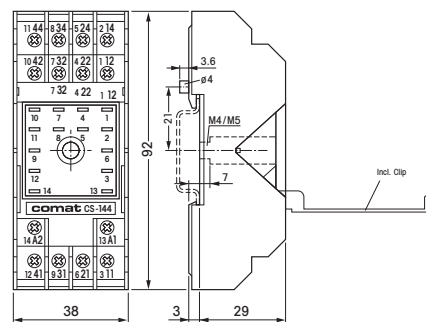

### Technical approvals, conformities

See table on page 53.

## CS-118

### Socket for miniature plug-in relays R7-A, R7-T

#### Type: CS-18

2-pole, 1 level  
integrated clip and marking label  
suitable for C80 series time relays with clip  
coil bridge bus bar to connect in A2  
plug-in slot for overvoltage suppressing units

**Rated current** **10 A**

#### Specifications

Rated load	10 A / 250 V
Insulation	Test voltage Vrms / 1 min
– All terminal/DIN rail	2.5 kV
– Terminal/terminal	2.5 kV
Cross section of connecting wire	
– Single wire	4 mm <sup>2</sup> , 2 x 1.5 mm <sup>2</sup>
– Multi wire	2.5 mm <sup>2</sup> / AWG 16, 2 x 1 mm <sup>2</sup> / AWG 18
Max. screw torque	0.7 Nm
Screw dimensions	M3, Pozi, slot
Integrated retaining clip/plastic	for relays C7
Labelling space	detachable
Connection label	1...8, DIN/EN
Mounting	DIN rail TS35 or panel mounting
Ambient temperature operation / storage	-40 (no ice) ... +70 °C / -40 ... +80 °C
Weight	37 g

**Associated plug-in 8-pin relays** **R7-A, R7-T**

**Type** **CS-118**

#### Accessories

Coil bridge bus bar	<b>S7-B</b>
Retaining clip, plastic	<b>RC-G</b>

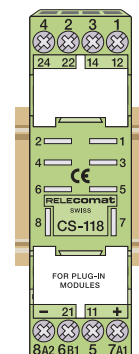

#### Connection diagram

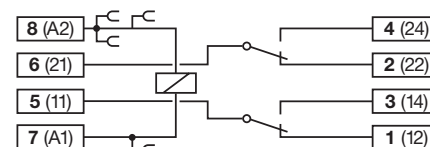

#### Dimensions [mm]

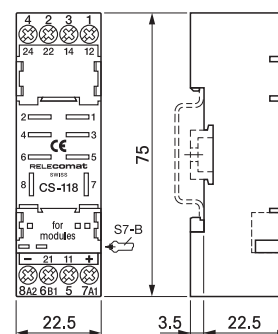

#### Technical approvals, conformities

See table on page 53.



Notes



## Technical approvals, conformities

Type	EN 50155						EN 61373	NF F 16-101/102		EN 45545-2		UL	
	Temperature rating	Power supply				Protective coating PCB	Schock & vibrations test	Smoke gas index F	Inflammability I	R23	R24	Listed	
		S1	S2	C1	C2								
Relays													
C31D/R	TX	YES	YES	YES	NO	N/A	Category 1, Class B	F2	I3			E120922	
C32D/R	TX	YES	YES	YES	NO	N/A	Category 1, Class B	F2	I3			E120922	
R3-N3...	T3	YES					Category 1, Class B						
R4-A4...	T1	YES	Approval in process										
R7-A2...	T3	YES					Category 1, Class B						
R7-T2...	T3	YES					Category 1, Class B						
C203.6R	TX	YES	YES	YES	NO	YES	Category 1, Class B	F2	I3	HL2	HL2		
CINT-21	TX	YES	NO	YES	NO	NO	Category 1, Class B	F2	I3	HL2	HL2		
CINT-22	TX	YES	NO	YES	NO	NO	Category 1, Class B	F2	I3	HL2	HL2		
CINT-25	T2	YES	NO	YES	NO	NO	Category 1, Class B	F2	I3	HL2	HL2		
CINT-61	TX	YES	NO	YES	NO	NO	Category 1, Class B	F2	I3	HL2	HL2		
CINT-62	TX	YES	NO	YES	NO	NO	Category 1, Class B	F2	I3	HL2	HL2		
CINT-63	TX	YES	NO	YES	NO	NO	Category 1, Class B	F2	I3	HL2	HL2		
Time relays													
RIC20-...		YES	YES	YES	NO	NO	In approval						
RIC25-...		YES	YES	YES	NO	NO	Category 1, Class B						
CIM1R	TX	YES	YES	YES	YES	YES	Category 1, Class B	F2	I3	HL2	HL2		
CIM12R	TX	YES	YES	YES	YES	YES	Category 1, Class B	F2	I3	HL2	HL2		
CIM13R	TX	YES	YES	YES	YES	YES	Category 1, Class B	F2	I3	HL2	HL2		
CIM2R	TX	YES	YES	YES	YES	YES	Category 1, Class B	F2	I3	HL2	HL2		
CIM22R	TX	YES	YES	YES	YES	YES	Category 1, Class B	F2	I3	HL2	HL2		
CIM23R	TX	YES	YES	YES	YES	YES	Category 1, Class B	F2	I3	HL2	HL2		
CIM3R	TX	YES	YES	YES	YES	YES	Category 1, Class B	F2	I3	HL2	HL2		
CIM32R	TX	YES	YES	YES	YES	YES	Category 1, Class B	F2	I3	HL2	HL2		
CIM33R	TX	YES	YES	YES	YES	YES	Category 1, Class B	F2	I3	HL2	HL2		
CT32R (modul)	TX	YES	YES	YES	NO	YES	Category 1, Class B	F2	I3	HL2	HL2		
CT32.31R (set)	TX	YES	YES	YES	NO	YES	Category 1, Class B	F2	I3				
CT32.32R (set)	TX	YES	YES	YES	NO	YES	Category 1, Class B	F2	I3				
CT33R (modul)	TX	YES	YES	YES	NO	YES	Category 1, Class B	F2	I3	HL2	HL2		
CT33.31R (set)	TX	YES	YES	YES	NO	YES	Category 1, Class B	F2	I3				
CT33.32R (set)	TX	YES	YES	YES	NO	YES	Category 1, Class B	F2	I3				
CT36R (modul)	TX	YES	YES	YES	NO	YES	Category 1, Class B	F2	I3	HL2	HL2		
CT36.31R (set)	TX	YES	YES	YES	NO	YES	Category 1, Class B	F2	I3				
CT32.32R (set)	TX	YES	YES	YES	NO	YES	Category 1, Class B	F2	I3				
Monitoring relays													
CT512R (modul)	TX	YES	YES	YES	NO	YES	Category 1, Class B	F2	I3	HL2	HL2		
CT512.31R (set)	TX	YES	YES	YES	NO	YES	Category 1, Class B	F2	I3				
CT512.32R (set)	TX	YES	YES	YES	NO	YES	Category 1, Class B	F2	I3				
CT515R (modul)	TX	YES	YES	YES	NO	YES	Category 1, Class B	F2	I3	HL2	HL2		
CT515.31R (set)	TX	YES	YES	YES	NO	YES	Category 1, Class B	F2	I3				
CT515.32R (set)	TX	YES	YES	YES	NO	YES	Category 1, Class B	F2	I3				
CT516R (modul)	TX	YES	YES	YES	NO	YES	Category 1, Class B	F2	I3	HL2	HL2		
CT516.31R (set)	TX	YES	YES	YES	NO	YES	Category 1, Class B	F2	I3				
CT516.32R (set)	TX	YES	YES	YES	NO	YES	Category 1, Class B	F2	I3				
CT524R (modul)	TX	YES	YES	YES	NO	YES	Category 1, Class B	F2	I3	HL2	HL2		
CT524.31R (set)	TX	YES	YES	YES	NO	YES	Category 1, Class B	F2	I3				
CT524.32R (set)	TX	YES	YES	YES	NO	YES	Category 1, Class B	F2	I3				
MRI11R		Approval in process											
MRI32R		Approval in process											
MRM11R		Approval in process											
MRM32R		Approval in process											
MRU11R		Approval in process											
MRU32R		Approval in process											
ESU-D2R	TX	YES	YES	YES	YES	YES	Category 1, Class B	F2	I3				
Sockets													
C11A	TX	N/A	N/A	N/A	N/A	N/A	Category 1, Class B	F2	I3	HL2	HL2	E120922	
C12B0	TX	N/A	N/A	N/A	N/A	N/A	Category 1, Class B	F2	I3	HL2	HL2	E120922	
CS-118	TX	N/A	N/A	N/A	N/A	N/A	Approval in process	F2	I3	HL2	HL2	E196531	
CS-144	TX	N/A	N/A	N/A	N/A	N/A	Category 1, Class B	F2	I3	HL2	HL2	E196531	



COMAT AG • BERNSTR. 4  
CH-3076 WORB

TEL. +41 (0)31 838 55 77

FAX +41 (0)31 838 55 99

[www.comat.ch](http://www.comat.ch) • [info@comat.ch](mailto:info@comat.ch)

ООО «ПОЛИГОН» — официальный дистрибьютор Comat Releco на территории Российской Федерации (812) 325-42-20 • [www.poligon.info/releco](http://www.poligon.info/releco)