

Type 1 AC power Surge Protector

DS150VG



The DS150VG is a Heavy Duty Type 1 AC Surge Protector Device (SPD) designed to be connected at the entrance of the electrical installation. This SPD provides an efficient protection against direct and indirect effects and is particularly useful in a high lightning density area where the risk of heavy surge current or even direct strike is high (i.e. : buildings equipped with lightning rods)

The DS150VG is a one-pole SPD and can be used in common mode (2, 3 or 4 DS150VGs connected between L/PE and N/PE = CT1 configuration) or common and differential mode (DS150VGs connected between L/N and 1 x DS100EG between N/PE = CT2 configuration). See pages A20 and A21.

This SPD is designed to withstand a 15 kA lightning current (10/350 μ s impulse). It is based on specific heavy duty GDT and high energy MOV block : this technology allows the best behaviour possible on AC network (no follow current and no leakage current) and a very low residual voltage.

The SPD is DIN rail compatible and is featured with double terminal for line wire to allow improved connection to AC network.

To meet standards, the DS150VG includes a thermal disconnection mechanism, fault indicator and an internal microswitch for remote signalling.

- **Type 1 Surge protector**
- **Iimp : 15 kA on 10/350 μ s impulse**
- **Low voltage Up**
- **Internal disconnection, status indicator and remote signalling**
- **IEC 61643-11 and EN 61643-11 compliance**
- **UL 1449 ed. 2 recognition**

Dimensions and Diagram

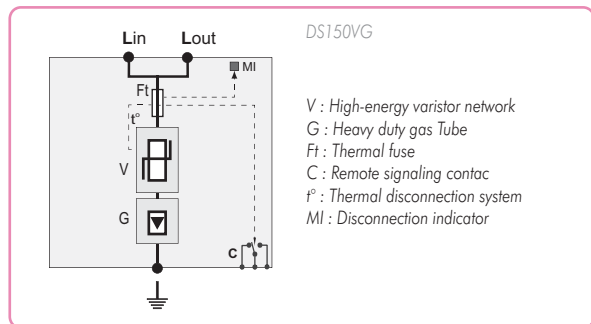
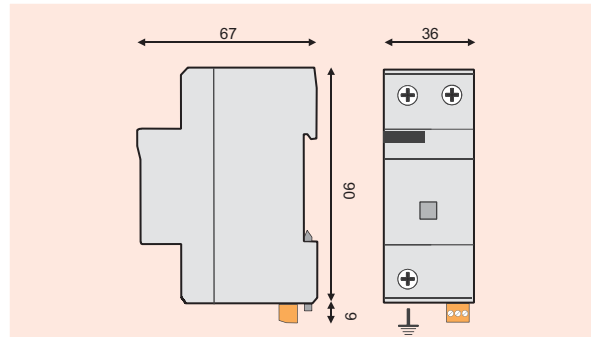

Characteristics

CITEL part number	DS150VG-400	DS150VG-300	DS150VG-120
Network	230/400V	230/400V	120/208V
Connection mode	L/PE	L/N	L/N, L/PE
AC system	IT, TT, TN	TT, TN	TT, TN
Max operating voltage	Uc 400 Vac	300 Vac	150 Vac
TOV withstand	U _T 400 Vac	300 Vac	150 Vac
Operating current	Ic none	none	none
Leakage current at Uc			
Follow current	If none	none	none
Nominal discharge current	In 20 kA	20 kA	20 kA
15 x 8/20 μ s impulses			
Maximal discharge current	I _{max} 40 kA	40 kA	40 kA
max. withstand 8/20 μ s			
Max. lightning current by pole	I _{imp} 15 kA	15 kA	15 kA
max. withstand 10/350 μ s			
Residual voltage (at I _{imp})	U _{res} 0,8 kV	0,6 kV	0,4 kV
Protection level (at In)	U _p 1,5 kV	1,5 kV	1 kV
Admissible short-circuit current	25000 A	25000 A	25000 A
Associated disconnection devices			
Thermal disconnector	internal		
Fuses	Fuses type gG - 100 A max. (see Note 1)		
Installation ground fault breaker	Type «S» or delayed		
Mechanical characteristics			
Dimensions	see diagram		
Connection	by screw terminals : 6-35 mm ² / by bus		
Disconnection indicator	1 mechanical indicator		
Remote signaling of disconnection	output on changeover contact		
Mounting	symmetrical rail 35 mm		
Operating temperature	-40/+85 °C		
Protection class	IP20		
Housing material	Thermoplastic PEI UL94-5VA		
Standards compliance			
IEC 61643-11	International	Low Voltage SPD - Test Class I and II	
EN 61643-11	Europe	Low Voltage SPD - Test Class I and II	
NF EN 61643-11	France	Parafoudre Basse Tension - Essais Classe I et II	
UL1449 ed.2	USA	Low Voltage TVSS	

Note 1: Rating in compliance with nominal discharge current. In order to increase service continuity, higher rating can be used (up to 200 A). For further information, please consult product instructions.