

- ▶ Voltage monitoring in 3-phase- and 1-phase mains
- ▶ Multifunction
- ▶ Monitoring of phase failure and asymmetry
- ▶ Monitoring of phase sequence selectable
- ▶ Connection of neutral wire optional
- ▶ 2 change over contacts
- ▶ Plug-in housing
- ▶ Width 38mm



## Technical data

### 1. Functions

Voltage monitoring in 3-phase- and 1-phase mains with adjustable thresholds, adjustable tripping delay, monitoring of phase failure, phase sequence and asymmetry with adjustable asymmetry and the following functions (selectable by means of rotary switch):

UNDER	Undervoltage monitoring
UNDER+SEQ	Undervoltage monitoring and monitoring of phase sequence
WIN	Monitoring the window between Min and Max
WIN+SEQ	Monitoring the window between Min and Max and monitoring of phase sequence

### 2. Time ranges

	Adjustment range
Start-up suppression time (Start):	-
Tripping delay (Delay):	0.1s - 10s

### 3. Indicators

Red LED ON/OFF:	indication of failure of the corresponding threshold
Red LED flashes:	indication of tripping delay of the corresponding threshold
Yellow LED ON/OFF:	indication of relay output

### 4. Mechanical design

Self-extinguishing plastic housing, IP rating IP40  
 Mounted on screw terminal socket 11-pols in accordance with IEC 60067-1-18a  
 Mounting position: any  
 Sockproof terminal connection according to VBG 4 (PZ1 required), IP rating IP20  
 Tightening torque: max. 1Nm  
 Terminal capacity:  
 1 x 0.5 to 2.5mm<sup>2</sup> with/without multicore cable end  
 1 x 4mm<sup>2</sup> without multicore cable end  
 2 x 0.5 to 1.5mm<sup>2</sup> with/without multicore cable end  
 2 x 2.5mm<sup>2</sup> flexible without multicore cable end

### 5. Input circuit

Supply voltage: (= measuring voltage)  
 Pins: (S10)-S5-S6-S7 / (N)-L1-L2-L3  
 Rated voltage  $U_N$ : see table ordering information or printing on the unit  
 Tolerance: -30% to +30% of  $U_N$   
 Rated consumption: 9VA (2W)  
 Rated frequency: AC 48 to 63Hz  
 Duration of operation: 100%  
 Reset time: 500ms  
 Hold-up time: -  
 Drop-out voltage: >20% of supply voltage  
 Overvoltage category: III (in accordance with IEC 60664-1)  
 Rated surge voltage: 4kV

### 6. Output circuit

2 potential free change over contacts  
 Rated voltage: 250V AC  
 Switching capacity: 1250VA (5A / 250V)  
 Fusing: 5A fast acting  
 Mechanical life: 20 x 10<sup>6</sup> operations  
 Electrical life: 2 x 10<sup>5</sup> operations at 1000VA resistive load  
 Switching frequency: max. 6/min at 1000VA resistive load (in accordance with IEC 60947-5-1)  
 Overvoltage category: III (in accordance with IEC 60664-1)  
 Rated surge voltage: 4kV

### 7. Measuring circuit

Measuring variable: 3(N)-, Sinus, 48 to 63Hz  
 Measuring input: (= supply voltage)  
 Pins: (S10)-S5-S6-S7 / (N)-L1-L2-L3  
 Overload capacity: determined by tolerance specified for supply voltage  
 Input resistance: -  
 Switching threshold  $U_S$ :  
 Max: 80%...130% of  $U_N$   
 Min: 70%...120% of  $U_N$   
 Overvoltage category: III (in accordance with IEC 60664-1)  
 Rated surge voltage: 4kV

### 8. Accuracy

Base accuracy: ±5% of maximum scale value  
 Adjustment accuracy: ≤5% of maximum scale value  
 Repetition accuracy: ≤2%  
 Voltage influence: -  
 Temperature influence: ≤1%

### 9. Ambient conditions

Ambient temperature: -25 to +55°C  
 Storage temperature: -25 to +70°C  
 Transport temperature: -25 to +70°C  
 Relative humidity: 15% to 85% (in accordance with IEC 60721-3-3 class 3K3)  
 Pollution degree: 2, if built in 3 (in accordance with IEC 60664-1)

## Functions

For all functions the LED's Min and Max are flashing alternating (the relay is fallen off), when the minimum value for the measured voltage was chosen to be greater than the maximum value. If a failure already exists when the device is activated, the output relay remains in off-position and the LED for the corresponding threshold is illuminated. The device includes separately every phase voltage (L-N) and monitors it according to the selected function (UNDER or WINDOW).

### Undervoltage monitoring (UNDER, UNDER+SEQ)

When the measured voltage (one of the phase voltages) falls below the value adjusted at the Min-regulator, the set interval of the tripping delay (Delay) begins (red LED Min flashes). After the interval has expired (red LED Min illuminated), the output relay R switches into off-position (yellow LED not illuminated). The output relay R switches into on-position again (yellow LED illuminated), when the measured voltage (all phase voltages) exceeds the value adjusted at the Max-regulator.

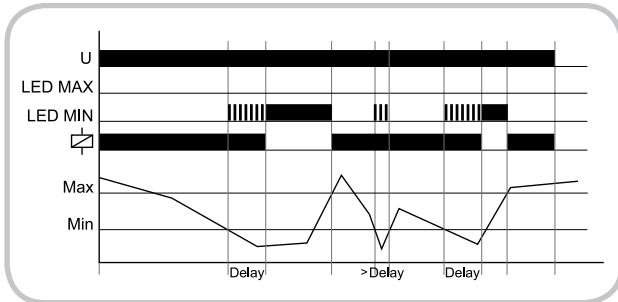

### Window function (WIN, WIN+SEQ)

The output relay R switches into on-position (yellow LED illuminated), when the measured voltage (all phase voltages) exceeds the value adjusted at the Min-regulator. When the measured voltage (one of the phase voltages) exceeds the value adjusted at the Max-regulator, the set interval of tripping delay (Delay) begins (red LED Max flashes). After the interval has expired (red LED Max illuminated) the output relay R switches into off-position (yellow LED not illuminated). The output relay switches into on-position again (yellow LED illuminated) when the measured voltage falls below the value adjusted at the Max-regulator (red LED Max not illuminated). When the measured voltage (one of the phase voltage) falls below the value adjusted at the Min-regulator, the set interval of tripping delay (Delay) begins again (red LED Min flashes). After the interval has expired (red LED Min illuminated), the output relay R switches into off-position (yellow LED not illuminated).

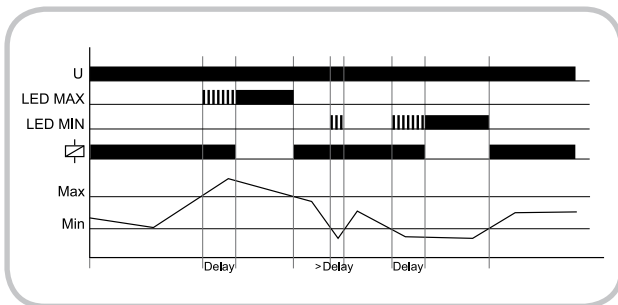

### Phase sequence monitoring (SEQ)

Phase sequence monitoring is selectable for all functions. In single phase circuit, the phase sequence monitoring must be disconnected. If a change in phase sequence is detected (red LED SEQ illuminated), the output relay R switches into off-position after the set interval of tripping delay (Delay) has expired (yellow LED not illuminated).

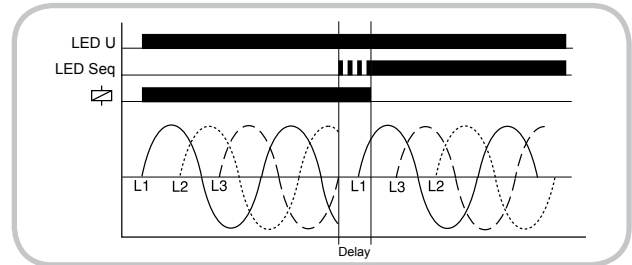

### Phase failure monitoring

The output relay R switches into off-position (yellow LED not illuminated), when one of the three phases fails.

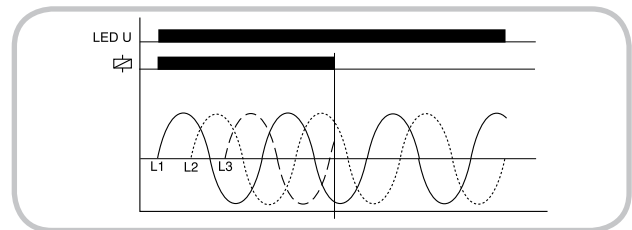

### Asymmetry monitoring

The output relay R switches into off-position (yellow LED not illuminated) when the asymmetry exceeds the value set at the ASYM-regulator. Reverse voltages of a consumer (e.g. a motor which continues to run on two phases only) do not effect the disconnection.

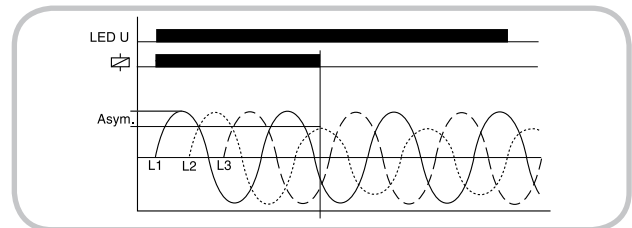

### Neutral wire break

The device monitors every phase (L1, L2 and L3) against the neutral wire N. A shift of neutral point occurs by an asymmetrical phase load if the neutral wire breaks in the power line. If one of the phase voltages exceeds the value adjusted at the trip point, the set interval of tripping delay (Delay) begins (red LED Min or Max flashes). After the interval has expired (red LED Min or Max illuminated), the output relay switches into off-position (yellow LED not illuminated).

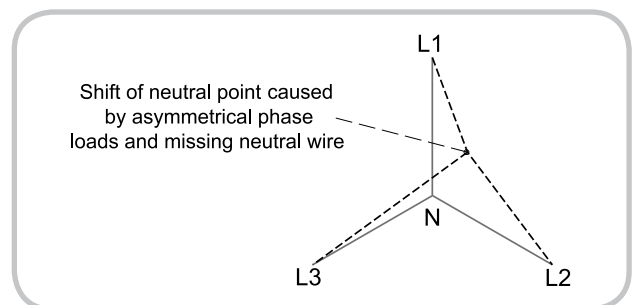

## Connections

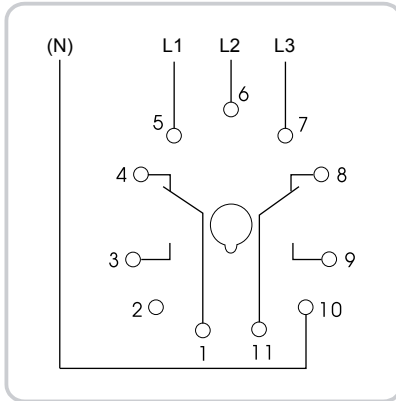

## Dimensions

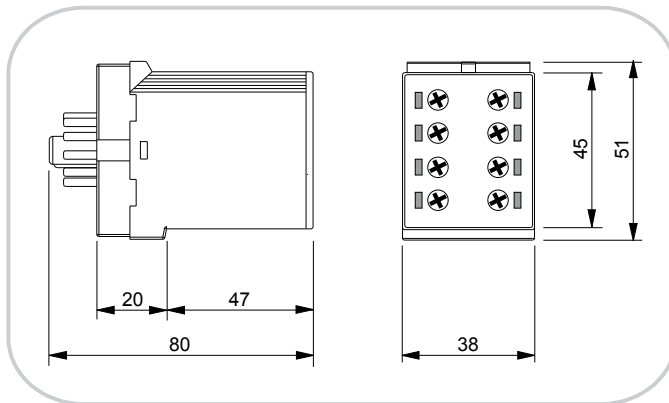

## Ordering information

Type	Rated voltage $U_N$	Functions	Switching threshold $U_s$	Tripping delay (Delay)	Part Nr. (PQ 1)
K3YM400VSY20	3(N)~ 400/230V	U, U+Seq, Win, Win+Seq	Max: 80% to 130% of $U_N$ Min: 70% to 120% of $U_N$ Asymmetry: 5%...30%	0,1s to 10s	1380402