

- ▶ Power factor monitoring ($\cos\phi$) in 1- or 3-phase mains
- ▶ Multifunction
- ▶ Fault latch
- ▶ Recognition of disconnected consumers
- ▶ Suitable for VFI (10 to 100Hz)
- ▶ Supply voltage selectable via power modules
- ▶ 2 change-over contacts
- ▶ Width 22.5mm
- ▶ Industrial design



Technical data

1. Functions

Load monitoring ($\cos\phi$) in 1- or 3-phase mains with adjustable thresholds, timing for start-up suppression and tripping delay separately adjustable and the following functions (selectable by means of rotary switch)

OVER	Overload monitoring
OVER+LATCH	Overload monitoring with fault latch
UNDER	Underload monitoring
UNDER+LATCH	Underload monitoring with fault latch
WIN	Monitoring the window between Min and Max
WIN+LATCH	Monitoring the window between Min and Max with fault latch

2. Time ranges

	Adjustment range	
Start-up suppression time:	1s	100s
Tripping delay:	0.1s	40s

3. Indicators

Green LED ON:	indication of supply voltage
Green LED flashes:	indication of start-up suppression time
Yellow LED R ON/OFF:	indication of relay output
Yellow LED I=0 ON/OFF:	indication of disconnected consumers
Red LED ON/OFF:	indication of failure of the corresponding threshold
Red LED flashes:	indication of tripping delay of the corresponding threshold

4. Mechanical design

Self-extinguishing plastic housing, IP rating IP40
 Mounted on DIN-Rail TS 35 according to EN 60715
 Mounting position: any
 Shockproof terminal connection according to VBG 4 (PZ1 required), IP rating IP20
 Tightening torque: max. 1Nm
 Terminal capacity:
 1 x 0.5 to 2.5mm² with/without multicore cable end
 1 x 4mm² without multicore cable end
 2 x 0.5 to 1.5mm² with/without multicore cable end
 2 x 2.5mm² flexible without multicore cable end

5. Input circuit

Supply voltage:	12 to 400V AC	terminals A1-A2 (galvanically separated) selectable via power modules TR2
Tolerance:		according to specification of power module
Rated frequency:		according to specification of power module
Rated consumption:	2VA (1.5W)	
Duration of operation:	100%	
Reset time:	500ms	
Residual ripple for DC:	-	
Drop-out voltage:	>30% of the supply voltage	
Overvoltage category:	III (in accordance with IEC 60664-1)	
Rated surge voltage:	4kV	

6. Output circuit

2 potential free change-over contacts	
Rated voltage:	250V AC
Switching capacity:	750VA (3A / 250V AC)
If the <u>distance</u> between the devices is <u>less than 5mm!</u>	
Switching capacity:	1250VA (5A / 250V AC)
If the <u>distance</u> between the devices is <u>greater than 5mm!</u>	
Fusing:	5A fast acting
Mechanical life:	20 x 10 ⁶ operations
Electrical life:	2 x 10 ⁵ operations
Switching frequency:	at 1000VA resistive load max. 60/min at 100VA resistive load max. 6/min at 1000VA resistive load (in accordance with IEC 60947-5-1) III (in accordance with IEC 60664-1)
Overvoltage category:	4kV
Rated surge voltage:	4kV

7. Measuring circuit

Measured variable:	AC Sinus (10 to 100Hz)
Measuring-input voltage:	
1-phase mains	40 to 415V AC (max. 300V against ground) terminals L1i-L2/L3
3-phase mains	3~ 40/23 to 415/240V, terminals L1i-L2-L3
Overload capacity:	
1-phase mains	500V
3-phase mains	3~ 500/289V
Input resistance:	≥1MΩ
Measuring-input current:	0.5 to 10A, terminals L1i-L1k (for I>8A distance >5mm)
Overload capacity:	12A permanently
Input resistance:	5mΩ
Switching threshold $\cos\phi$:	
Max:	0.2 to 1.0
Min:	0.1 to 0.99
Overvoltage category:	III (in accordance with IEC 60664-1)
Rated surge voltage:	4kV

8. Accuracy

Base accuracy:	±5% (equivalent to 5% at $\cos\phi = 0.8$)
Frequency response:	-
Adjustment accuracy:	±5% (at $\cos\phi = 0.8$)
Repetition accuracy:	±1.8° (equivalent to 1.8% at $\cos\phi = 0.8$)
Voltage influence:	-
Temperature influence:	≤0.1% / °C

9. Ambient conditions

Ambient temperature:	-25 to +55°C (in accordance with IEC 60068-1) -25 to +40°C (in accordance with UL 508)
Storage temperature:	-25 to +70°C
Transport temperature:	-25 to +70°C
Relative humidity:	15% to 85% (in accordance with IEC 60721-3-3 class 3K3)
Pollution degree:	3 (in accordance with IEC 60664-1)
Vibration resistance:	10 to 55Hz 0.35mm (in accordance with IEC 60068-2-6)
Shock resistance:	15g 11ms (in accordance with IEC 60068-2-27)

Functions

When the supply voltage U is applied, the output relays switch into on-position (yellow LED R and LED I=0 illuminated) and the set interval of the start-up suppression (START) begins (green LED U flashes). Changes of the measured power factor ($\cos\phi$) during this period do not affect the state of the output relay. After the interval has expired the green LED is illuminated steadily.

For all the functions the LEDs MIN and MAX are flashing alternating, when the minimum value for the measured power factor was chosen to be greater than the maximum value.

Overload monitoring (OVER, OVER+LATCH)

When the measured power factor exceeds the value adjusted at the MAX-regulator, the set interval of the tripping delay (DELAY) begins (red LED MAX flashes). After the interval has expired (red LED MAX illuminated), the output relays switch into off-position (yellow LED R not illuminated). The output relays again switch into on-position (yellow LED R illuminated), when the measured power factor falls below the value adjusted at the MIN-regulator (red LED MAX not illuminated).

If the fault latch is activated (OVER+LATCH) and the measured power factor remains above the MAX-value longer than the set interval of the tripping delay, the output relays remain in the off-position even if the measured power factor falls below the value adjusted at the MIN-regulator. After resetting the failure (interrupting and re-applying the supply voltage), the output relays switch into on-position and a new measuring cycle begins with the set interval of the start-up suppression (START).

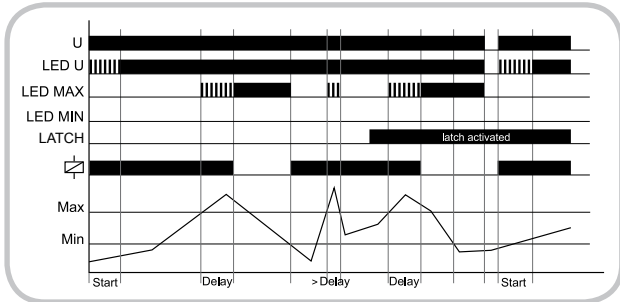

Underload monitoring (UNDER, UNDER+LATCH)

When the measured power factor falls below the value adjusted at the MIN-regulator, the set interval of the tripping delay (DELAY) begins (red LED MIN flashes). After the interval has expired (red LED MIN illuminated), the output relays switch into off-position (yellow LED R not illuminated). The output relays again switch into on-position (yellow LED R illuminated), when the measured power factor exceeds the value adjusted at the MAX-regulator.

If the fault latch is activated (UNDER+LATCH) and the measured power factor remains below the MIN-value longer than the set interval of the tripping delay, the output relays remain in the off-position even if the measured power factor exceeds the value adjusted at the MAX-regulator. After resetting the failure (interrupting and re-applying the supply voltage), the output relays switch into on-position and a new measuring cycle begins with the set interval of the start-up suppression (START).

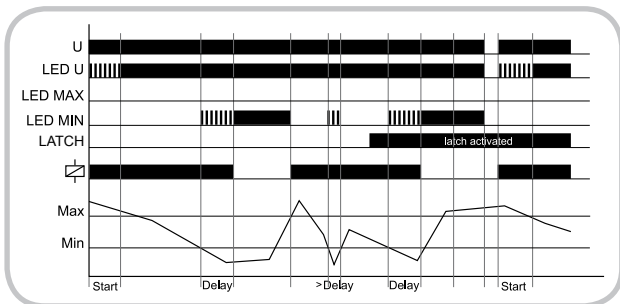

Window function (WIN, WIN+LATCH)

The output relays switch into on-position (yellow LED R illuminated) when the measured power factor exceeds the value adjusted at the MIN-regulator. When the measured power factor exceeds the value adjusted at the MAX-regulator, the set interval of the tripping delay (DELAY) begins (red LED MAX flashes). After the interval has expired (red LED MAX illuminated), the output relays switch into off-position (yellow LED R not illuminated). The output relays again switch into on-position (yellow LED R illuminated) when the measured power factor falls below the value adjusted at the MAX-regulator (red LED MAX not illuminated). When the measured power factor falls below the value adjusted at the MIN-regulator, the set interval of the tripping delay (DELAY) begins again (red LED MIN flashes). After the interval has expired (red LED MIN illuminated), the output relays switch into off-position (yellow LED R not illuminated).

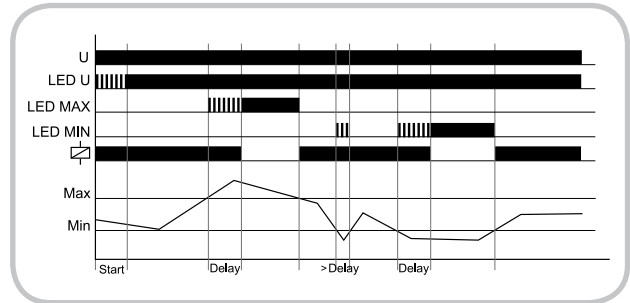

If the fault latch is activated (WIN+LATCH) and the measured power factor remains below the MIN-value longer than the set interval of the tripping delay, the output relays remain in the off-position even if the measured power factor exceeds the value adjusted at the MIN-regulator. If the measured power factor remains above the MAX-value longer than the set interval of the tripping delay, the output relays remain in the off-position even if the measured power factor falls below the value adjusted at the MAX-regulator. After resetting the failure (interrupting and re-applying the supply voltage), the output relays switch into on-position and a new measuring cycle begins with the set interval of the start-up suppression (START).

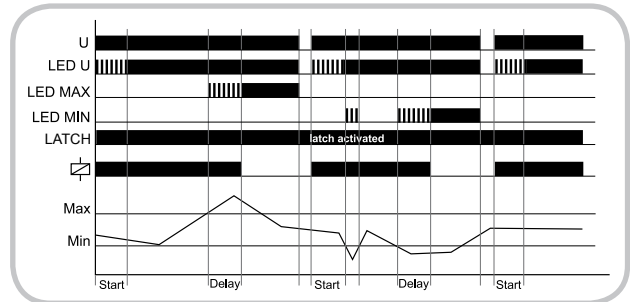

Recognition of disconnected consumers

When the current flow between L1i and L1k is interrupted (yellow LED I=0 illuminated) and no fault has been stored the output relays switch into on-position resp. remain in on-position (yellow LED R illuminated).

When the current flow is restored, the measuring cycle is restarted with the set interval of the start-up suppression (START).

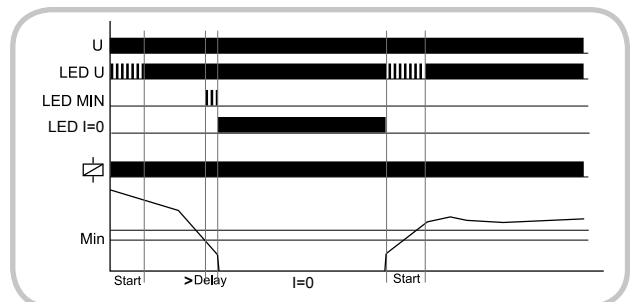

Connections

- Connected to 3~ 400V mains with power module 24V AC without fault latch

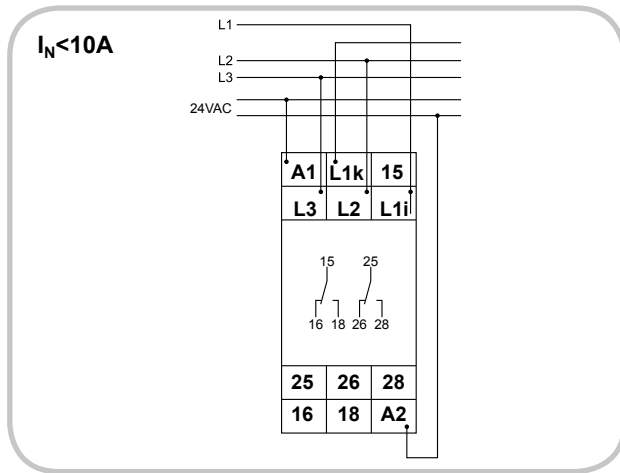

- Connected to 1~ 230V mains with power module 230V AC without fault latch

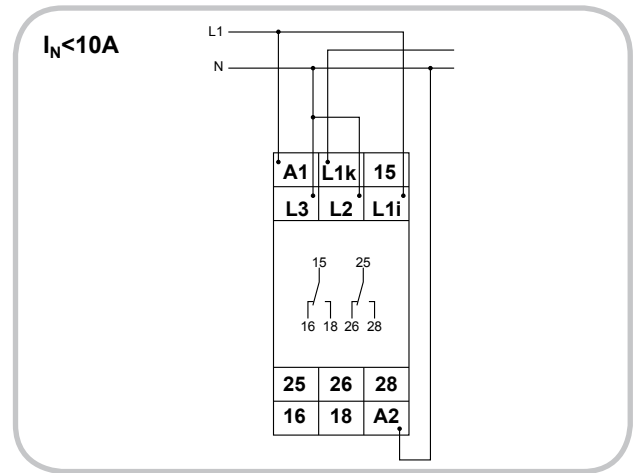

- Connected to 3~ 400V mains with power module 400V AC and fault latch

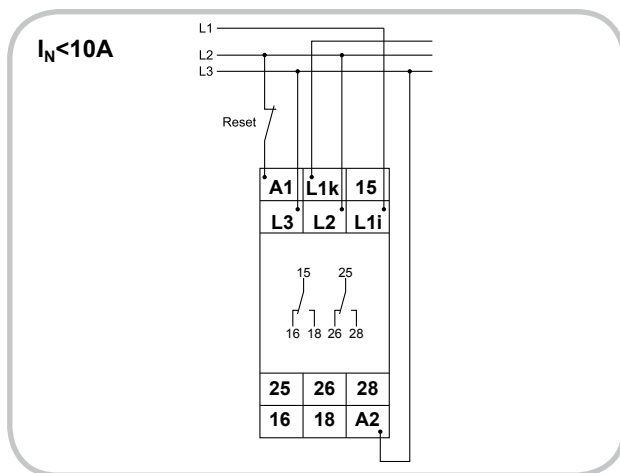

- Connected to 3~ 400V mains with power module 400V AC and fault latch

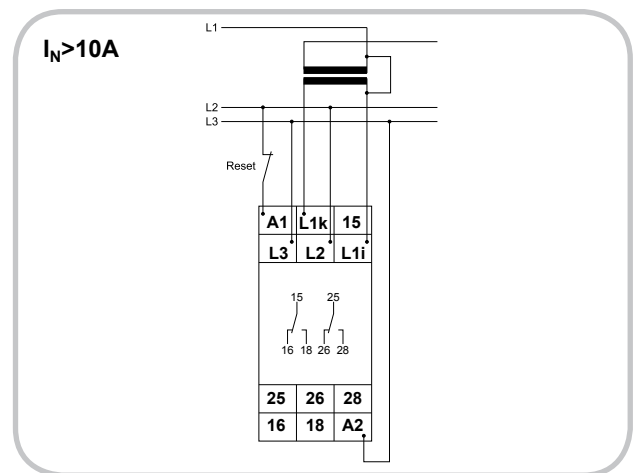

Subject to alterations and errors

Dimensions

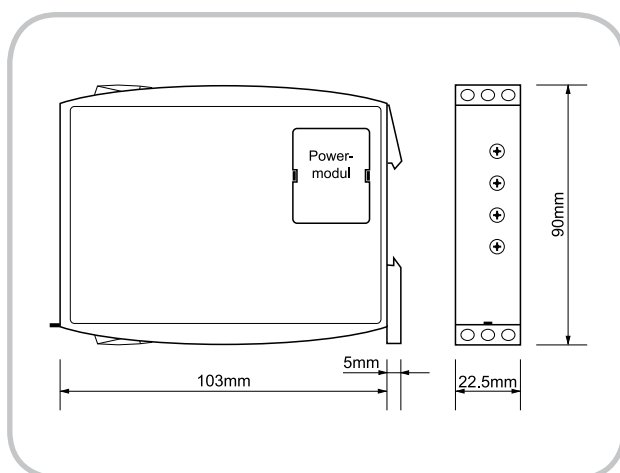

G2CM400V10AL20

 **Notes**

Subject to alterations and errors