

- ▶ AC/DC voltage monitoring in 1-phase mains
- ▶ Multifunction
- ▶ 16.6 to 400Hz
- ▶ Fault latch
- ▶ 1 change-over contact
- ▶ Width 22.5mm
- ▶ Industrial design



Technical data

1. Functions

AC/DC voltage monitoring in 1-phase mains with adjustable thresholds, timing for start-up suppression and tripping delay separately adjustable and the following functions (selectable by means of rotary switch)

OVER	Overvoltage monitoring
OVER+LATCH	Overvoltage monitoring with fault latch
UNDER	Undervoltage monitoring
UNDER+LATCH	Undervoltage monitoring with fault latch
WIN	Monitoring the window between Min and Max
WIN+LATCH	Monitoring the window between Min and Max with fault latch

2. Time ranges

	Adjustment range	
Start-up suppression time (Start):	0s	10s
Tripping delay (Delay):	0.1s	10s

3. Indicators

Green LED ON:	indication of supply voltage
Green LED flashes:	indication of start-up suppression time
Yellow LED ON/OFF:	indication of relay output
Red LED ON/OFF:	indication of failure of the corresponding threshold
Red LED flashes:	indication of tripping delay of the corresponding threshold

4. Mechanical design

Self-extinguishing plastic housing, IP rating IP40
 Mounted on DIN-Rail TS 35 according to EN 50022
 Mounting position: any
 Shockproof terminal connection according to VBG 4 (PZ1 required), IP rating IP20
 Tightening torque: max. 1Nm
 Terminal capacity:
 1 x 0.5 to 2.5mm² with/without multicore cable end
 1 x 4mm² without multicore cable end
 2 x 0.5 to 1.5mm² with/without multicore cable end
 2 x 2.5mm² flexible without multicore cable end

5. Input circuit

Supply voltage:	230V AC	terminals A1-A2 (galvanically separated)
Tolerance:	-15% bis +15%	
Rated frequency:	50/60Hz	
Rated consumption:	2VA (1.5W)	
Duration of operation:	100%	
Reset time:	500ms	
Residual ripple for DC:	-	
Drop-out voltage:	>30% of the supply voltage	
Overvoltage category:	III (according to IEC 60664-1)	
Rated surge voltage:	4kV	

6. Output circuit

1 potential free change-over contact	
Rated voltage:	250V AC
Switching capacity (distance <5mm):	750VA (3A / 250V AC)
Switching capacity (distance >5mm):	1250VA (5A / 250V AC)
Fusing:	5A fast acting
Mechanical life:	20 x 10 ⁶ operations
Electrical life:	2 x 10 ⁵ operations at 1000VA resistive load
Switching frequency:	max. 60/min at 100VA resistive load max. 6/min at 1000VA resistive load (according to IEC 947-5-1)
Overvoltage category:	III (according to IEC 60664-1)
Rated surge voltage:	4kV

7. Measuring circuit

Fusing:	max. 20A (according to UL 508)
Measured variable:	DC or AC Sinus (16.6 to 400Hz)
Input:	
150V AC/DC	terminals E-F1(+)
300V AC/DC	terminals E-F2(+)
500V AC/DC	terminals E-F3(+)
Overload capacity:	
150V AC/DC	300V _{eff}
300V AC/DC	440V _{eff}
500V AC/DC	600V _{eff}
Input resistance:	
150V AC/DC	270kΩ
300V AC/DC	470kΩ
500V AC/DC	1MΩ
Switching threshold	
Max:	10% to 100% of U _N
Min:	5% to 95% of U _N
Overvoltage category:	III (according to IEC 60664-1)
Rated surge voltage:	4kV

8. Accuracy

Base accuracy:	±5% (of maximum scale value)
Frequency response:	-10% to +5% (at 16.6 to 400Hz)
Adjustment accuracy:	≤5% (of maximum scale value)
Repetition accuracy:	≤2%
Voltage influence:	≤0.5%
Temperature influence:	≤0.1% / °C

9. Ambient conditions

Ambient temperature:	-25 to +55°C (according to IEC 68-1) -25 to +40°C (according to UL 508)
Storage temperature:	-25 to +70°C
Transport temperature:	-25 to +70°C
Relative humidity:	15% to 85% (according to IEC 721-3-3 class 3K3)
Pollution degree:	3 (according to IEC 60664-1)
Vibration resistance:	10 to 55Hz 0.35mm (according to IEC 68-2-6)
Shock resistance:	15g 11ms (according to IEC 68-2-27)

Functions

When the supply voltage U is applied, the output relays switch into on-position (yellow LED illuminated) and the set interval of the start-up suppression (START) begins (green LED U flashes). Changes of the measured voltage during this period do not affect the state of the output relay. After the interval has expired the green LED is illuminated steadily.

For all the functions the LEDs MIN and MAX are flashing alternating, when the minimum value for the measured voltage was chosen to be greater than the maximum value.

Overvoltage monitoring (OVER, OVER+LATCH)

When the measured voltage exceeds the value adjusted at the MAX-regulator, the set interval of the tripping delay (DELAY) begins (red LED MAX flashes). After the interval has expired (red LED MAX illuminated), the output relays switch into off-position (yellow LED not illuminated). The output relays again switch into on-position (yellow LED illuminated), when the measured voltage falls below the value adjusted at the MIN-regulator (red LED MAX not illuminated).

If the fault latch is activated (OVER+LATCH) and the measured voltage remains above the MAX-value longer than the set interval of the tripping delay, the output relays remain in the off-position even if the measured voltage falls below the value adjusted at the MIN-regulator. After resetting the failure (interrupting and re-applying the supply voltage), the output relays switch into on-position and a new measuring cycle begins with the set interval of the start-up suppression (START).

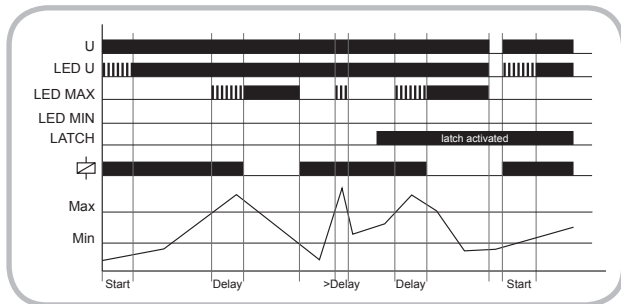

Undervoltage monitoring (UNDER, UNDER+LATCH)

When the measured voltage falls below the value adjusted at the MIN-regulator, the set interval of the tripping delay (DELAY) begins (red LED MIN flashes). After the interval has expired (red LED MIN illuminated), the output relays switch into off-position (yellow LED not illuminated). The output relays again switch into on-position (yellow LED illuminated), when the measured voltage exceeds the value adjusted at the MAX-regulator.

If the fault latch is activated (UNDER+LATCH) and the measured voltage remains below the MIN-value longer than the set interval of the tripping delay, the output relays remain in the off-position even if the measured voltage exceeds the value adjusted at the MAX-regulator. After resetting the failure (interrupting and re-applying the supply voltage), the output relays switch into on-position and a new measuring cycle begins with the set interval of the start-up suppression (START).

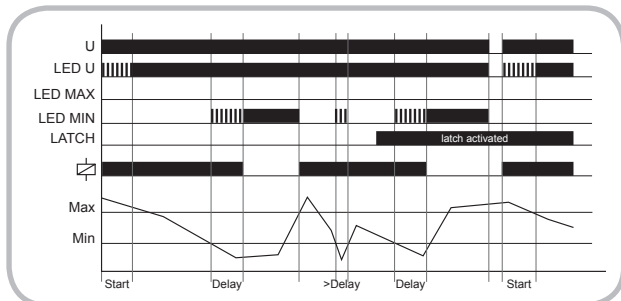

Window function (WIN, WIN+LATCH)

The output relays switch into on-position (yellow LED illuminated) when the measured voltage exceeds the value adjusted at the MIN-regulator. When the measured voltage exceeds the value adjusted at the MAX-regulator, the set interval of the tripping delay (DELAY) begins (red LED MAX flashes). After the interval has expired (red LED MAX illuminated), the output relays switch into off-position (yellow LED not illuminated). The output relays again switch into on-position (yellow LED illuminated) when the measured voltage falls below the value adjusted at the MAX-regulator (red LED MAX not illuminated). When the measured voltage falls below the value adjusted at the MIN-regulator, the set interval of the tripping delay (DELAY) begins again (red LED MIN flashes). After the interval has expired (red LED MIN illuminated), the output relays switch into off-position (yellow LED not illuminated).

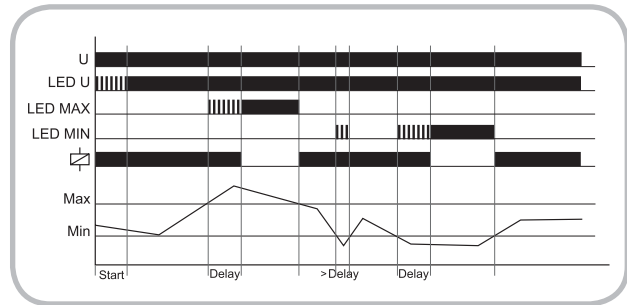

If the fault latch is activated (WIN+LATCH) and the measured voltage remains below the MIN-value longer than the set interval of the tripping delay, the output relays remain in the off-position even if the measured voltage exceeds the value adjusted at the MIN-regulator. If the measured voltage remains above the MAX-value longer than the set interval of the tripping delay, the output relays remain in the off-position even if the measured voltage falls below the value adjusted at the MAX-regulator. After resetting the failure (interrupting and re-applying the supply voltage), the output relays switch into on-position and a new measuring cycle begins with the set interval of the start-up suppression (START).

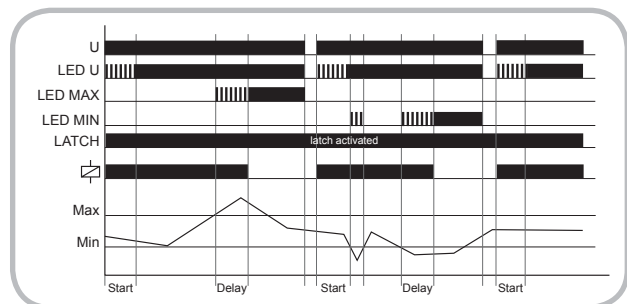

Connections

► Range 150V, supply voltage 230V AC and fault latch

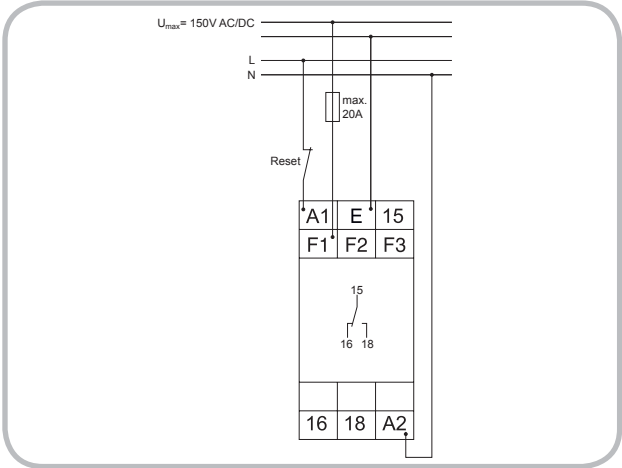

► Range 300V, supply voltage 230V AC and fault latch

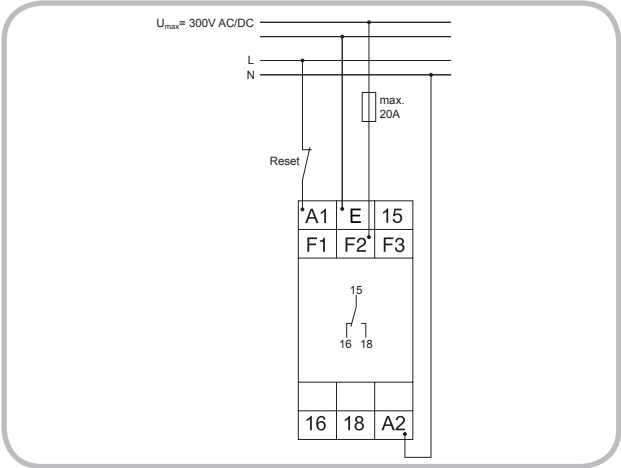

► Range 500V, supply voltage 230V AC without fault latch

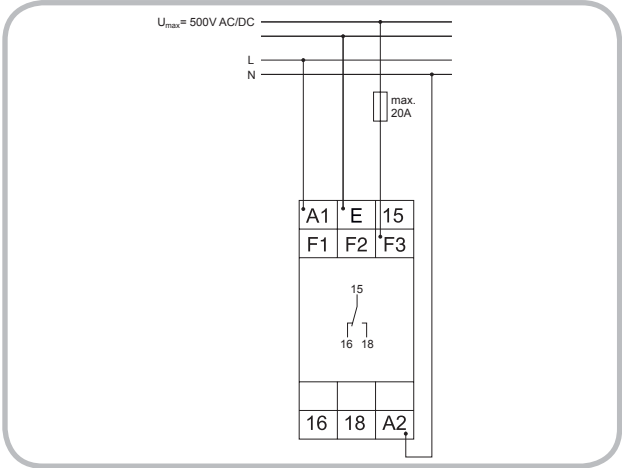

Dimensions

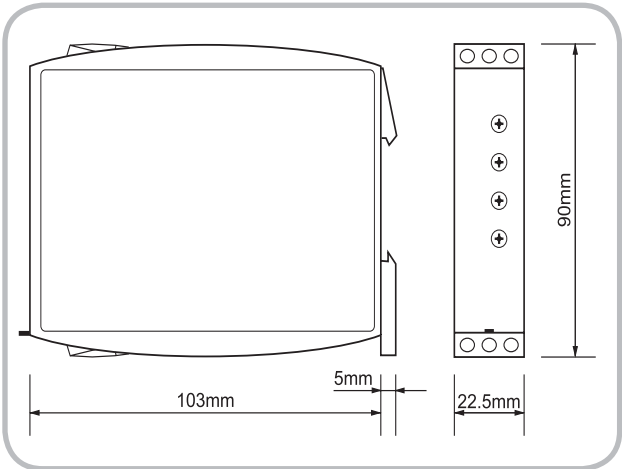

Subject to alterations and errors

G2UM500VL10

 **Notes**

Subject to alterations and errors